



NEHRU COLLEGE OF ENGINEERING AND RESEARCH CENTRE
(NAAC Accredited)
(Approved by AICTE, Affiliated to APJ Abdul Kalam Technological University,
Kerala)



DEPARTMENT OF MECHANICAL ENGINEERING

COURSE MATERIALS



EST110 ENGINEERING GRAPHICS

VISION OF THE INSTITUTION

To mould true citizens who are millennium leaders and catalysts of change through excellence in education.

MISSION OF THE INSTITUTION

NCERC is committed to transform itself into a center of excellence in Learning and Research in Engineering and Frontier Technology and to impart quality education to mould technically competent citizens with moral integrity, social commitment and ethical values.

We intend to facilitate our students to assimilate the latest technological know-how and to imbibe discipline, culture and spiritually, and to mould them in to technological giants, dedicated research scientists and intellectual leaders of the country who can spread the beams of light and happiness among the poor and the underprivileged.

ABOUT DEPARTMENT

- ◆ Established in: 2002
- ◆ Course offered: B.Tech in Mechanical Engineering
- ◆ Approved by AICTE New Delhi and Accredited by NAAC

- ◆ Affiliated to the University of Dr. A P J Abdul Kalam Technological University.

DEPARTMENT VISION

Producing internationally competitive Mechanical Engineers with social responsibility & sustainable employability through viable strategies as well as competent exposure oriented quality education.

DEPARTMENT MISSION

1. Imparting high impact education by providing conducive teaching learning environment.
2. Fostering effective modes of continuous learning process with moral & ethical values.
3. Enhancing leadership qualities with social commitment, professional attitude, unity, team spirit & communication skill.
4. Introducing the present scenario in research & development through collaborative efforts blended with industry & institution.

PROGRAMME EDUCATIONAL OBJECTIVES

PEO1: Graduates shall have strong practical & technical exposures in the field of Mechanical Engineering & will contribute to the society through innovation & enterprise.

PEO2: Graduates will have the demonstrated ability to analyze, formulate & solve design engineering / thermal engineering / materials & manufacturing / design issues & real life problems.

PEO3: Graduates will be capable of pursuing Mechanical Engineering profession with good communication skills, leadership qualities, team spirit & communication skills.

PEO4: Graduates will sustain an appetite for continuous learning by pursuing higher education & research in the allied areas of technology.

PROGRAM OUTCOMES (POS)

Engineering Graduates will be able to:

1. **Engineering knowledge:** Apply the knowledge of mathematics, science, engineering fundamentals, and an engineering specialization to the solution of complex engineering problems.
2. **Problem analysis:** Identify, formulate, review research literature, and analyze complex engineering problems reaching substantiated conclusions using first principles of mathematics, natural sciences, and engineering sciences.
3. **Design/development of solutions:** Design solutions for complex engineering problems and design system components or processes that meet the specified needs with appropriate consideration for the public health and safety, and the cultural, societal, and environmental considerations.
4. **Conduct investigations of complex problems:** Use research-based knowledge and research methods including design of experiments, analysis and interpretation of data, and synthesis of the information to provide valid conclusions.

5. **Modern tool usage:** Create, select, and apply appropriate techniques, resources, and modern engineering and IT tools including prediction and modeling to complex engineering activities with an understanding of the limitations.
6. **The engineer and society:** Apply reasoning informed by the contextual knowledge to assess societal, health, safety, legal and cultural issues and the consequent responsibilities relevant to the professional engineering practice.
7. **Environment and sustainability:** Understand the impact of the professional engineering solutions in societal and environmental contexts, and demonstrate the knowledge of, and need for sustainable development.
8. **Ethics:** Apply ethical principles and commit to professional ethics and responsibilities and norms of the engineering practice.
9. **Individual and teamwork:** Function effectively as an individual, and as a member or leader in diverse teams, and in multidisciplinary settings.
10. **Communication:** Communicate effectively on complex engineering activities with the engineering community and with society at large, such as, being able to comprehend and write effective reports and design documentation, make effective presentations, and give and receive clear instructions.
11. **Project management and finance:** Demonstrate knowledge and understanding of the engineering and management principles and apply these to one's own work, as a member and leader in a team, to manage projects and in multidisciplinary environments.
12. **Life-long learning:** Recognize the need for, and have the preparation and ability to engage in independent and life-long learning in the broadest context of technological change.

PROGRAM SPECIFIC OUTCOMES (PSO)

PSO1: graduates able to apply principles of engineering, basic sciences & analytics including multi variant calculus & higher order partial differential equations..

PSO2: Graduates able to perform modeling, analyzing, designing & simulating physical systems, components & processes.

PSO3: Graduates able to work professionally on mechanical systems, thermal systems & production systems.

COURSE OUTCOMES

CO1	Draw the projection of points and lines located in different quadrants.
CO2	Prepare multiview orthographic projections of objects by visualizing them in different Positions.
CO3	Draw sectional views and develop surfaces of a given object.
CO4	Prepare pictorial drawings using the principles of isometric and perspective projections to visualize objects in three dimensions.
CO5	Convert 3D views to orthographic views and vice versa.
CO6	Obtain multiview projections and solid models of objects using CAD tools.

MAPPING OF COURSE OUTCOMES WITH PROGRAM OUTCOMES

	PO1	PO2	PO3	PO4	PO5	PO6	PO7	PO8	PO9	PO10	PO11	PO12	PSO1	PSO2	PSO3
CO1	3														
CO2	3														
CO3	3	1													
CO4	3									1					
CO5	3									2					
CO6	3				3					3					

Note: H-Highly correlated=3, M-Medium correlated=2, L-Less correlated=1

SYLLABUS

SYLLABUS

General Instructions :

- First angle projection to be followed
- Section A practice problems to be performed on A4 size sheets
- Section B classes to be conducted on CAD lab
- CIA for section A carries 25 marks (15 marks for 1 test and Class work 10 marks)
- CIA for section B carries 15 marks (10 marks for 1 test and Class work 5 marks)

SECTION A

Module 1

Introduction : Relevance of technical drawing in engineering field. Types of lines, Dimensioning, BIS code of practice for technical drawing.

Orthographic projection of Points and Lines: Projection of points in different quadrants, Projection of straight lines inclined to one plane and inclined to both planes. Trace of line. Inclination of lines with reference planes True length of line inclined to both the reference planes.

Module 2

Orthographic projection of Solids: Projection of Simple solids such as Triangular, Rectangle, Square, Pentagonal and Hexagonal Prisms, Pyramids, Cone and Cylinder. Projection of solids in simple position including profile view. Projection of solids with axis inclined to one of the reference planes and with axis inclined to both reference planes.

Module 3

Sections of Solids: Sections of Prisms, Pyramids, Cone, Cylinder with axis in vertical position and cut by different section planes. True shape of the sections. Also locating the section plane when the true shape of the section is given.

Development of Surfaces: Development of surfaces of the above solids and solids cut by different section planes. Also finding the shortest distance between two points on the surface.

Module 4

Isometric Projection: Isometric View and Projections of Prisms, Pyramids, Cone, Cylinder, Frustum of Pyramid, Frustum of Cone, Sphere, Hemisphere and their combinations.

Module 5

Perspective Projection: Perspective projection of Prisms and Pyramids with axis perpendicular to the ground plane, axis perpendicular to picture plane.

Conversion of Pictorial Views: Conversion of pictorial views into orthographic views and vice versa

SECTION B

(To be conducted in CAD Lab)

Introduction to Computer Aided Drawing: Role of CAD in design and development of new products, Advantages of CAD. Creating two dimensional drawing with dimensions using suitable software. Conversion of pictorial views into orthographic views. (Minimum 2 exercises mandatory)

Introduction to Solid Modelling: Creating 3D models of various components using suitable modelling software. (Minimum 2 exercises mandatory)

Text Books

1. Bhatt, N.D., Engineering Drawing, Charotar Publishing House Pvt. Ltd.
2. John, K.C. Engineering Graphics, Prentice Hall India Publishers.

Reference Books

1. Agrawal, B. and Agrawal, C.M., Engineering Drawing, Tata McGraw Hill Publishers.
2. Duff, J.M. and Ross, W.A., Engineering Design and Visualisation, Cengage Learning.
3. Kulkarni, D.M., Rastogi, A.P. and Sarkar, A.K., Engineering Graphics with AutoCAD, PHI.
4. Luzadff, W.J. and Duff, J.M., Fundamentals of Engineering Drawing, PHI.

QUESTION BANK**MODULE I**

Q:NO:	QUESTIONS	CO	KL
1	Draw the following points in a common xy line. Point A is 20mm above HP and 30mm in front of VP. Point B is 20mm above HP and 30mm behind VP. Point C is 20mm below HP and 30 mm behind VP. Point D is 20mm below HP and 30mm in front of VP. Point E is on HP and 25mm behind VP. Point F is in both HP and VP.	CO1	K5
2	Draw the projection of a line AB, 80mm long inclined at 30° to HP and parallel to VP. The line is 25mm in front of VP and 20mm above HP.	CO1	K5
3	The length of the front view of a line PQ which is parallel to HP and inclined 35° to VP is 60mm. The end P of the line is 20mm above HP and 25mm in front of VP. Draw its projection and find its true length.	CO1	K5
4	The end C of a line CD of length 90mm, is 15mm in front of VP and 35mm below HP. The end D is also 35mm below HP but 40mm behind VP. Draw the projection of the line and find its inclination with VP.	CO1	K5
5	Draw the projection of a line AB 100 mm long is inclined at 30° to HP and 45° to VP. The end A is 25mm above HP and 20mm in front of VP. Find its inclination with HP and VP also locate its traces.	CO1	K5
6	A line AB of 70mm long has its end A 20mm above HP and 15mm in front of VP the other end B is 50mm above HP and 60mm in front of VP. Draw its projection and find its inclination with HP and VP.	CO1	K5
7	A line AB 90mm long is inclined 30° to HP. Its end A is 12mm above HP and 20mm in front of VP its front view measures 65mm. Draw its projections and locate its traces.	CO1	K5
8	The top view of a 75mm long line AB measures 65mm while the length of its front view is 50mm. The end A is in the HP and 12mm in front of VP. Draw the projection and determine its inclination with H and VP.	CO1	K5
9	The end A of a line AB is 20mm below HP and 10mm behind VP. The other end B is 40mm below HP and 25mm behind VP. The distance between end projectors is 50mm draw its projections and find its true length and true inclinations, also locate its traces.	CO1	K5
10	The end A of a line AB is on HP and 25mm behind VP while the other end B is in VP and 50mm above HP. The end projector distance is 75mm. Draw its projection and find its true length and true inclinations, also locate its traces.	CO1	K5
11	The end R of a line RS is 25mm below HP and 40mm behind VP while the other end S is 50mm above HP and 20mm in front of VP. The distance between the end projectors is 50mm. Draw its projections and find its true length and true inclinations.	CO1	K5
12	A line PQ has its end P 15mm above HP and 25mm in front of VP. The line is inclined 20° to HP and its top view is 90mm. The end Q is in the 2 nd quadrant and is equidistant from both the reference planes. Draw the projection of the line and find its inclination with VP.	CO1	K5

13	A line AB 70mm long is inclined 35° to HP and 55° to VP. The end A is 10mm above HP and end B is 12mm in front of VP. Draw its projections.	CO1	K5
14	Draw the projection of a line AB, 80mm long inclined at 30° to HP and parallel to VP. The line is 25mm in front of VP and 20mm above HP.	CO1	K5

MODULE II

1	A hexagonal prism of base side 26mm and height 60mm is resting on its base on HP keeping its axis parallel to VP. Draw its projection if one of its base edge parallel to VP.	CO2	K5
2	A hexagonal pyramid of base side 26mm and axis 64mm long is resting on its apex in VP keeping its axis parallel to HP. Draw its projections if one of its base edge is parallel to HP.	CO2	K5
3	A pentagonal pyramid of base side 30mm and height 60mm is resting on one of its base edge on HP such that the slant face containing that resting edge is perpendicular to HP. Draw its projections.	CO2	K5
4	A square prism of base side 25mm and height 65mm is resting on one of its base edge in VP keeping its axis inclined 30° to VP. Draw its projections	CO2	K5
5	A square pyramid of base edge 30mm and axis 60mm long is resting on one of its base edge on HP. Its axis inclined 45° to HP and the resting edge makes an angle 60° with VP. draw its projections	CO2	K5
6	A hexagonal prism of base side 25mm and height 60 mm is resting on one of its base edge on HP. Draw its projections if its axis is inclined 60° to HP and the resting edge makes an angle of 40° with VP.	CO2	K5
7	A cone of base diameter 40mm and height 70mm has one of its generators on HP. Draw the projection if its axis is inclined 30° to VP.	CO2	K5
8	A pentagonal pyramid of base side 25mm and axis 60mm long is resting on one of its corner on HP in such a way that the slant edge containing the resting corner makes an angle of 45° with HP and in the top view the axis makes an angle of 30° with VP. Draw its projection.	CO2	K5
9	A hexagonal pyramid of base side 25mm and axis 65mm long is resting on one of its corner on HP. The axis of the pyramid is inclined 30° to HP and 45° to VP. Draw its projections.	CO2	K5
10	A square prism of base side 25mm and axis 60mm long has one of its base edges in VP. The axis of the prism is inclined 30° to VP and the resting edge makes an angle of 40° to HP. Draw its projections.	CO2	K5

MODULE III

1	A hexagonal prism of base side 20mm and height 50mm rests on its base upon HP, keeping one of its base edge perpendicular to VP. A section plane inclined 45° to HP cuts its axis at its middle. Draw the complete development of the sectioned prism including the sectioned surface. Also complete the true shape of the section.	CO3	K5
---	--------------------------------------------------------------------------------------------------------------------------------------------------------------------------------------------------------------------------------------------------------------------------------------------------------------------------------------------	-----	----

2	A cone of base diameter 70mm and height 70mm rests on its base upon HP. A section plane inclined 30° to Hp cuts the solid bisecting its axis. Draw the development of the lateral surface of the cone also the true shape of the section.	CO3	K5
3	A pentagonal pyramid of base edge 36mm and height 64mm is resting on its base upon HP keeping one of its base edge parallel and nearer to VP. A section plane inclined 30° to HP cuts the solid at its middle. Draw the development of the pyramid also the true shape of the section.	CO3	K5
4	A cylinder of base diameter 50mm and height 60mm is resting on its upon HP. A section plane inclined 30° to HP and passes through the extreme left corner of the cylinder cuts and removes the top portion of the cylinder. Draw the complete development of the truncated cylinder also the true shape of the section.	CO3	K5
5	A pentagonal pyramid of base side 30mm and height 60mm is resting on its base upon HP, keeping one of its base edge parallel and nearer to VP. A section plane inclined 45° to HP cuts the solid at a point 15mm in front of the vertical axis. Draw the projection of the pyramid and true shape of the section.	CO3	K5

MODULE IV

1	A pentagonal prism of base edge 30mm and height 60mm is resting on its base on HP, keeping one of its base edge parallel to VP. Draw the isometric view of the prism.	CO4	K5
2	A hexagonal pyramid of base edge 30mm and axis 65mm is resting on its base upon HP keeping one of its base edge parallel to VP draw its isometric projection.	CO4	K5
3	A cone of base diameter 50mm and axis 60mm long is resting on its base upon HP. Draw its isometric view.	CO4	K5
4	Draw the isometric view of a pentagonal pyramid of base side 40mm and height 80mm which is rests with its base centrally on a cylinder if diameter 120mm and height 40mm. The pyramid is placed in such a way that one of its base edges is parallel to VP.	CO4	K5
5	A sphere of radius 18mm is placed centrally over hexagonal slab of side 24mm and thickness 25mm. The slab is placed in such a way that one of its base edges is parallel to VP. Draw the isometric view of this combination.	CO4	K5
6	A cylinder of 80mm base diameter and 100mm height is resting on its upon HP. It is surmounted by a hemi sphere of 60mm diameter. Draw the isometric view and projection of this combination.	CO4	K5
7	Draw the isometric view of hexagonal pyramid of base edge 35mm and height 70mm is resting on its base upon HP keeping one of its base edges parallel to VP. A section plane inclined 30° to HP and perpendicular to VP is cuts the solid bisecting its axis.	CO4	K5
8	A cylinder of diameter 48mm and 60mm height, is resting upon its base on HP. A section plane inclined 45° to HP cuts the solid bisecting its axis. Draw the isometric view of the truncated solid.	CO4	K5

9	A pentagonal prism of base side 30mm and height 60mm is resting on its base upon HP keeping one of its base edge parallel and nearer to VP. A section plane 30° inclined to HP and passing through a point on the axis, 40mm above its base. Draw the isometric view of the prism.	CO4	K5
MODULE V			
1	A square pyramid side of base 50mm, height 75mm stands on the ground vertically with an edge of base parallel to & 20mm behind pp. the station point is 50mm in front of pp & 75mm above the ground. The central plane is located 40mm to the left of the axis of the solid. Draw the perspective projection.	CO5	K5
2	A rectangular block 32x22x16mm is lying on the ground on one of its largest faces. One of its vertical edge is on the picture plane & longer face containing that edge is inclined at 30° to picture plane. The station point is 52mm in front of pp, 35mm above the ground plane passing through the centre of the prism. Draw the perspective view of the block.	CO5	K5
3	A cone of diameter 50mm, height 75mm stands on the ground vertically on its base touching pp. the station point is 50mm in front of pp & 75mm above the ground. The central plane is located 40mm to the right of the axis of the solid. Draw the perspective projection.	CO5	K5

4

Draw the three views of the following objects.

CO5

K5

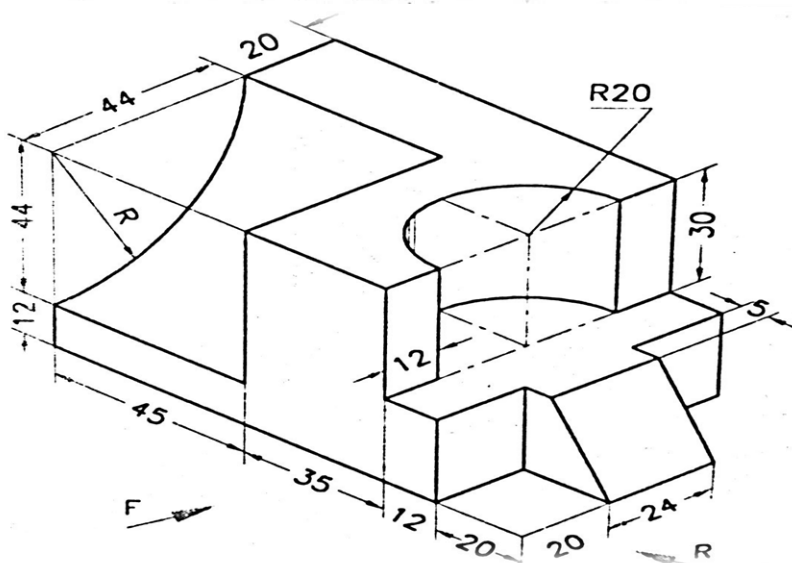
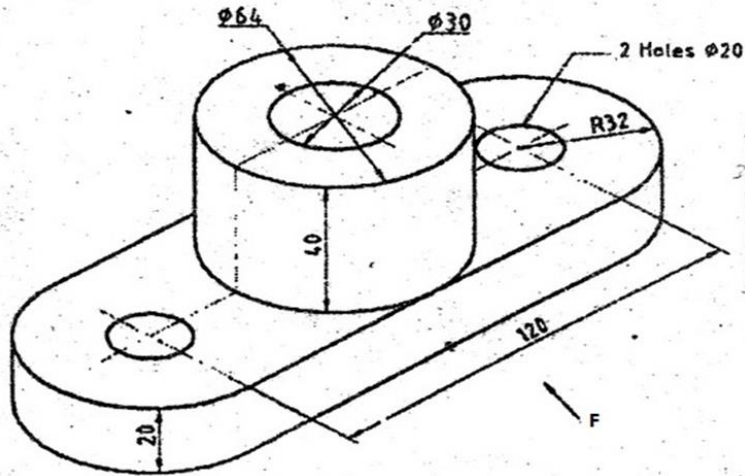
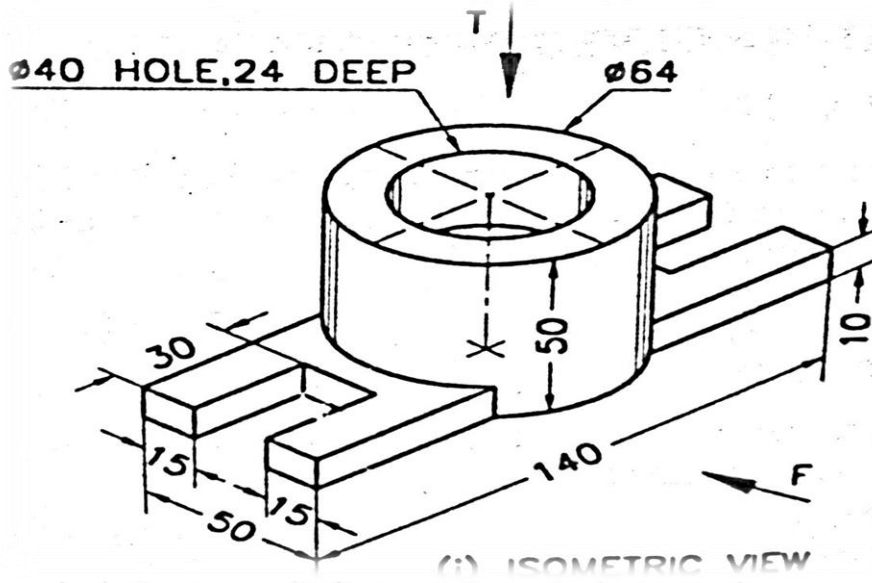

MODULE VI

1, 2

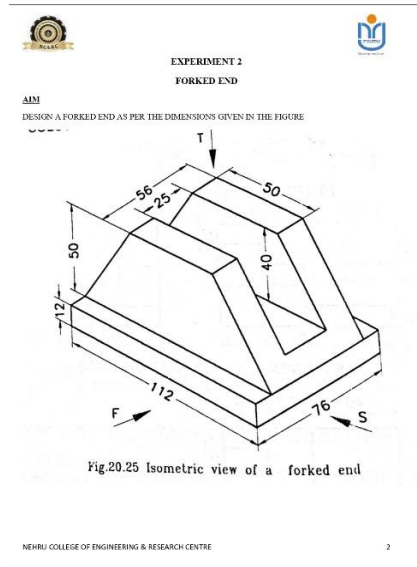
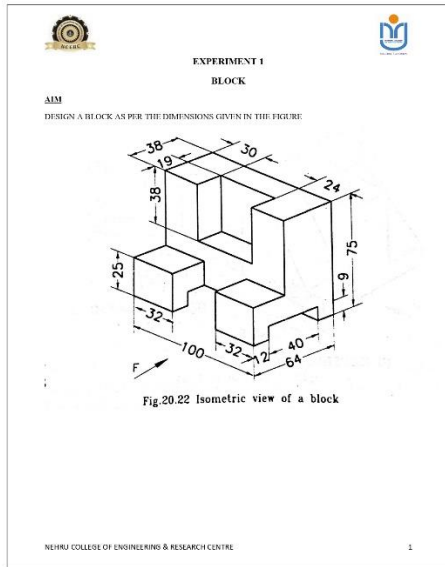

CO6

K5

3,4

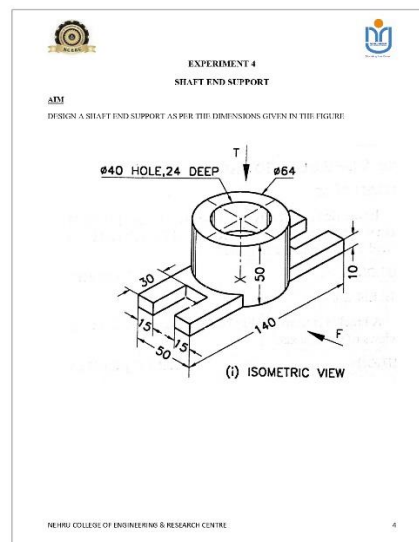
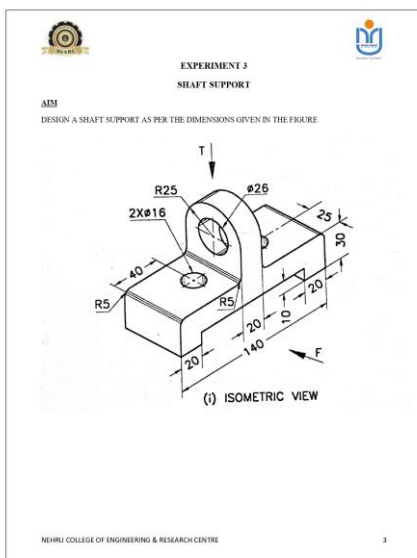

CO6

K5

5,6

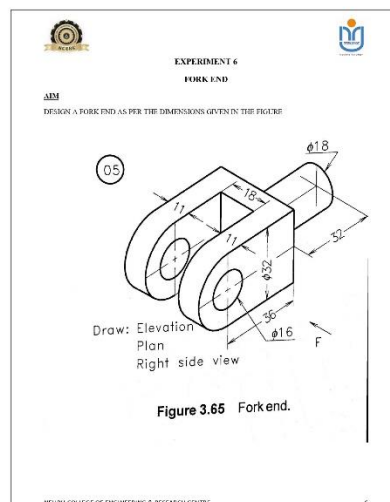
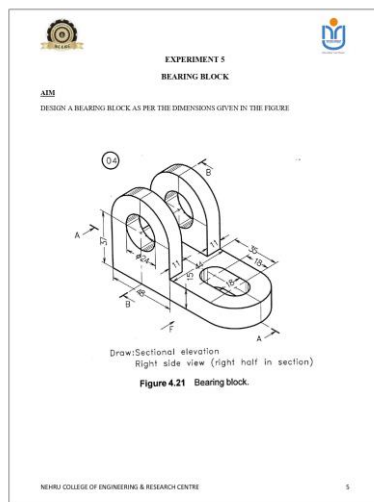

CO6

K5

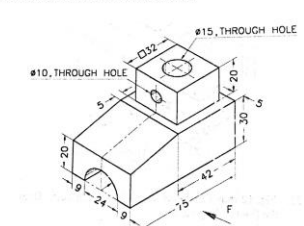
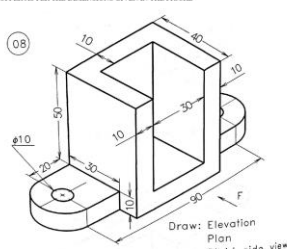
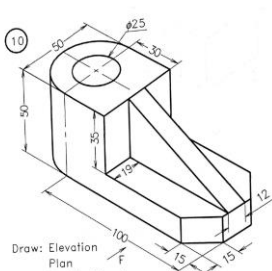
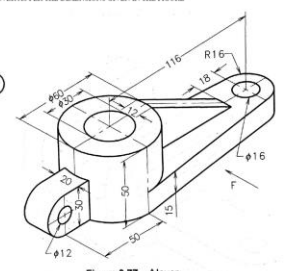
<p>7,8</p>	<p>EXPERIMENT 7 BLOCK 2</p> <p>AIM DESIGN A BLOCK AS PER THE DIMENSIONS GIVEN IN THE FIGURE</p>  <p>Fig.14 Block</p> <p>NEHRU COLLEGE OF ENGINEERING & RESEARCH CENTRE 7</p>	<p>EXPERIMENT 8 STOPPER</p> <p>AIM DESIGN A STOPPER AS PER THE DIMENSIONS GIVEN IN THE FIGURE</p>  <p>Figure 3.68 Astopper.</p> <p>NEHRU COLLEGE OF ENGINEERING & RESEARCH CENTRE 8</p>	<p>CO6</p>	<p>K5</p>
<p>9,10</p>	<p>EXPERIMENT 9 STEPPED BLOCK</p> <p>AIM DESIGN A STEPPED BLOCK AS PER THE DIMENSIONS GIVEN IN THE FIGURE</p>  <p>Draw: Elevation Plan Right side view</p> <p>Figure 3.70 A steppped block.</p> <p>NEHRU COLLEGE OF ENGINEERING & RESEARCH CENTRE 9</p>	<p>EXPERIMENT 10 LEVER</p> <p>AIM DESIGN A LEVER AS PER THE DIMENSIONS GIVEN IN THE FIGURE</p>  <p>Figure 3.77 A lever.</p> <p>NEHRU COLLEGE OF ENGINEERING & RESEARCH CENTRE 10</p>	<p>CO6</p>	<p>K5</p>

Dimensioning

A drawing describes the shape of an object. For complete details of an object, its size description is also required. The information like distance between surfaces and edges with tolerance, location of holes, machining symbols, surface finish, type of material, quantity, etc. is indicated on the drawing by means of lines, symbols, and notes. The process of furnishing this information on a technical drawing as per a code of practice is called *dimensioning*.

4.1 ELEMENTS OF DIMENSIONING

The following are the elements of dimensioning:

1. Projection line
2. Dimension line

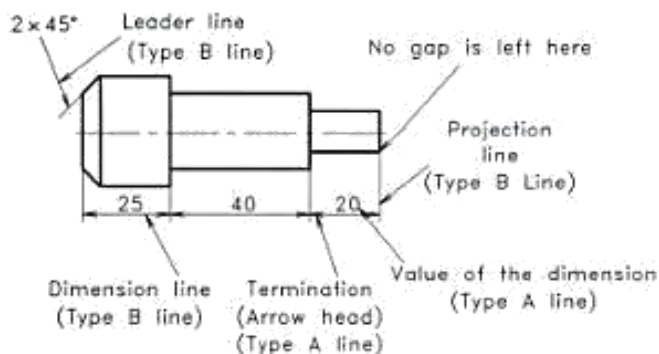

Fig. 4.1 Elements of dimensioning.

3. Leader line
4. Termination of dimension line
5. Dimensional text

These elements of dimensioning are shown in Fig. 4.1.

Projection Lines

These lines are drawn as continuous thin type B lines. They should be drawn:

1. Extending slightly beyond the respective dimension line
2. Perpendicular to the feature to be dimensioned,
3. Not crossing other lines as far as possible, and
4. May be drawn as extension of centre line or outline of the object as shown in Fig. 4.2.

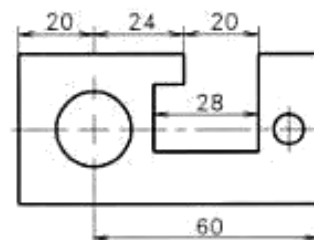

Fig. 4.2 Centre lines and outlines replace projection lines.

Dimension Lines

These lines are drawn as continuous thin type B lines. The following points may be noted while drawing a dimension line.

1. As far as possible, dimension line should not cross other lines.
2. A centre line or outlines of a part should not be used as a dimension line.
3. Dimension lines are preferred to be drawn from visible outlines and not from hidden lines.
4. A broken feature should be marked by an unbroken dimension line as shown in Fig. 4.3.



Fig. 4.3 Dimensioning of a broken feature.

Leader Lines

Leader lines are the lines referring to a feature (dimensions, object, outline, etc.) drawn as continuous thin type B lines. The tail end of the leader line should be terminated on a short horizontal bar below the lettering of a note. The head end of the leader line should be terminated in any one of the following forms (see Fig. 4.4)

1. With a dot within the outline of the object (surface).
2. With an arrow head on the outline of an object (edge).
3. Without a dot or an arrow head on a dimension line.

The following points may be noted while describing a leader line:

1. Leader line should not be parallel to adjacent dimension lines or projection lines, where confusion might arise.
2. Leader lines may be drawn at an angle not less than 30° with the horizontal or vertical.
3. The use of common leaders may be avoided.

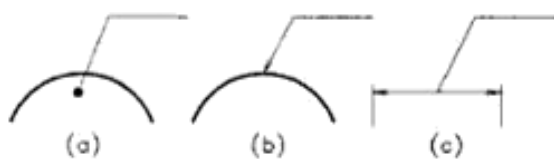

Fig. 4.4 Termination of leader lines.

Termination of Dimension Lines

Dimension lines should carry distinct terminations. Terminations are indicated either by arrowheads or by oblique strokes. The arrowheads are shown in Fig. 4.5(a).

The included angle between short lines forming the arrow head may be taken between 15° to 90° . The arrow head may be open, closed or closed and filled in. The oblique strokes are drawn as short lines inclined at 45° to the dimension line as shown in Fig. 4.5(b). While drawing arrow heads or oblique strokes the following points may be noted:

1. The size of the termination of the dimension line should be proportional to the size of the drawing on which they are used.

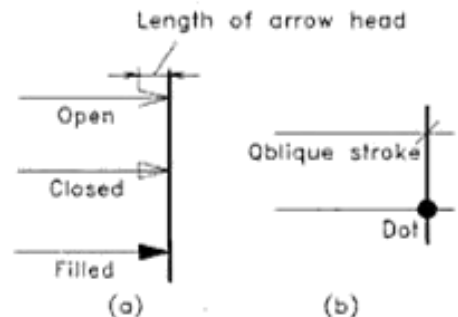

Fig. 4.5 Termination of dimension line.

2. Only one style of arrow head termination should be used on a single drawing. The shape of arrow head used in this book and that suggested for class work is shown in Fig. 4.6.

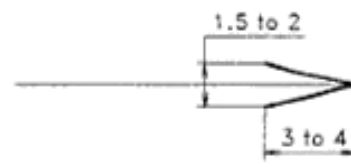

Fig. 4.6 Suggested arrow head shape.

3. Arrow heads may be shown within the limits of the dimension line, if space is available. See the left hand side dimension shown in Fig. 4.7.

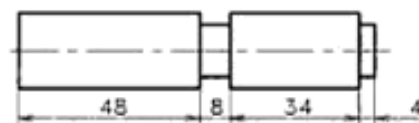

Fig. 4.7 Arrow heads within or outside the limits of dimension line.

4. Arrow head may be shown outside the intended limits of the dimension line if space is not available. See the marking of dimensional value 4 mm.

- If the space between the projection lines is too small for an arrow head, dots or oblique strokes may be used in the place of arrow heads as shown in Fig. 4.8.
- Only one arrow head termination is required to indicate the radius of a circle or an arc.

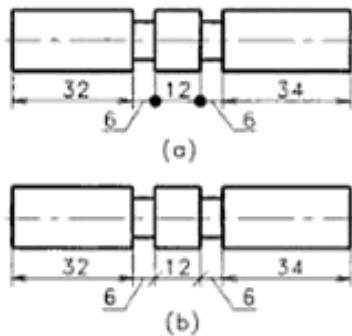

Fig. 4.8 Use of dot or oblique stroke.

Dimensional Text

Dimension is a numerical value expressed in an appropriate unit of measurement. The text size may be 3 mm to 4 mm in height depending on the drawing size. The location of the text value relative to the dimension line is decided by the *Method* of indicating them. While marking dimensional values in millimetres, there is no need of indicating mm after a value. But for the other units like cm, m or km, that should be indicated. If all the dimensions are marked in the same unit other than mm, it may be indicated as a note nearby the title block to avoid writing unit after each value.

4.2 METHODS OF INDICATING DIMENSIONAL VALUES

Two different methods of indicating dimensional values are suggested by *Bureau of Indian Standards* and are called *Method-1* and *Method-2*. Only one method is to be used in a drawing.

Method-1

In this method of dimensioning, the text should be placed aligning to the dimension line, satisfying the following conditions (see Fig. 4.9)

The dimensional values should be:

- Placed parallel to the dimension line.
- Placed above the dimension line.
- Not touching the dimension line.
- Placed at the middle of the dimension line as far as possible.

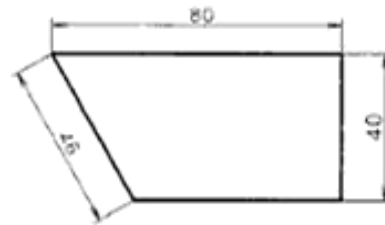

Fig. 4.9 Indicating dimensional value (Method-1).

- Placed in such a way that it can be read either from the bottom or right hand side of the drawing.
- Placed as indicated in Fig. 4.10 on inclined features.



Fig. 4.10 Indicating dimensional values on oblique dimension lines (Method-1).

- Indicated as shown either in Fig. 4.11(a) or in Fig. 4.11(b) for angular dimensioning. Here, the second one is simple, hence suggested for class work.

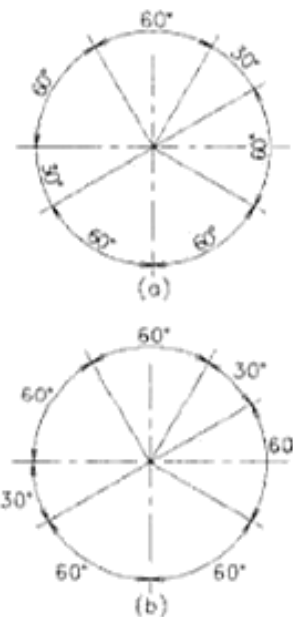

Fig. 4.11 Indicating angular dimensional values (Method-1).

Urheberrechtlich geschütztes Material

Projections of Points

Engineers, design and develop machines or structures and direct their construction. For this purpose, each and every information about the shape and size of the whole machine or structure, has to be noted in detail. Graphics is the fundamental method used to document as well as communicate them to the manufacturing group. The task of recording shapes and sizes of three-dimensional objects on two-dimension drawing sheets is done using the method of projection.

Projection is the representation of the image of an object on a plane surface, as it is observed by a viewer. The word, projection is of Latin origin and means to throw forward. Thus, a projection is an image of an object thrown upon a picture plane by means of straight lines or visual rays.

9.1 SYSTEMS OF PROJECTION

The shape of a three-dimensional object is described on the picture plane, that is drawing sheet, by means of projection. The methods of projection vary according to the direction in which the rays of sight are taken to the picture plane. If the rays are converging to a particular station point as in a camera, the result is a *perspective projection*. When the rays are parallel but at an angle to the picture plane, the projection is called *oblique projection*. If the rays are parallel as well as perpendicular to the picture plane, the method is called

orthographic projection. The different systems of projections can be classified as given below:

Pictorial views are obtained in all the above types of projections, except in the *multiview*. In multiview (orthographic) projection, the object shape is represented by two or more views taken at right angles to each other.

Perspective projection is described in Chapter 18 and oblique projection in Chapter 18. Isometric projection is comes under the principle of orthographic projection and is explained in Chapter 16.

9.2 MULTIVIEW PROJECTION

Multiview projection is an orthographic projection in which the exact shape of an object is represented by two or more separate views projected on planes that are perpendicular to each other. Each view shows the shape of the object for a particular view direction and these views altogether describe the object completely. Because of these reasons, this method of projection is the most widely used for preparing engineering drawings. The term *orthographic projection* is also used to represent multiview projection.

Planes of Projection

The plane surfaces, which are used to project the views of an

SYSTEMS OF PROJECTION

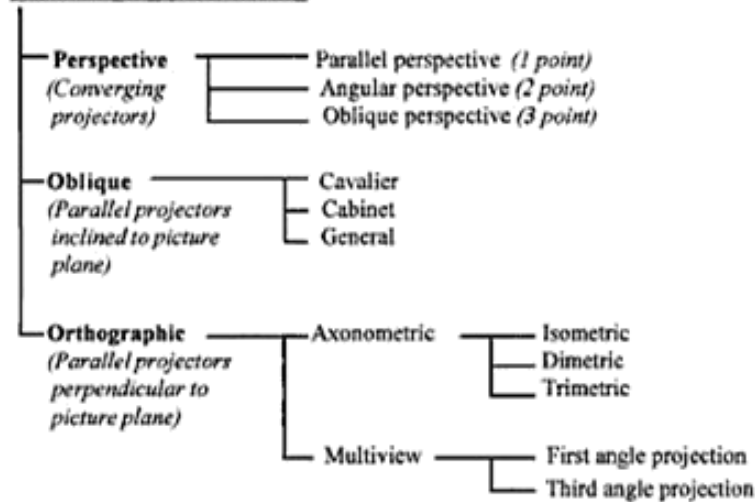

object in multiview projection are called *principal planes* or *reference planes*. Out of these mutually perpendicular planes, one plane is horizontal and it is called *horizontal plane* (HP). The other plane is vertical and it is called *vertical plane* (VP). A third vertical plane which is perpendicular to both HP and VP is also added in order to get the side or end view of the object projected. This plane is called *Profile Plane* (PP). These three mutually perpendicular coordinate planes produce eight compartments in the space called *octants* (see Fig. 9.1). Here, the intersection point of the three planes is considered as the origin O and the quadrants are counted in the anticlockwise direction, when viewed from the left side.

For this anticlockwise system, the front, top and left sides are as shown.

For easy understanding of the projection method, the right part of the octants containing four compartments (right side) may be eliminated. Then the left part forms the four quadrants as shown in Fig. 9.2. These imaginary reference planes are assumed as transparent and these planes form the basis to obtain views for describing objects in engineering problems.

The multiview projection method is classified into two types, such as *First angle projection* and *Third angle projection*.

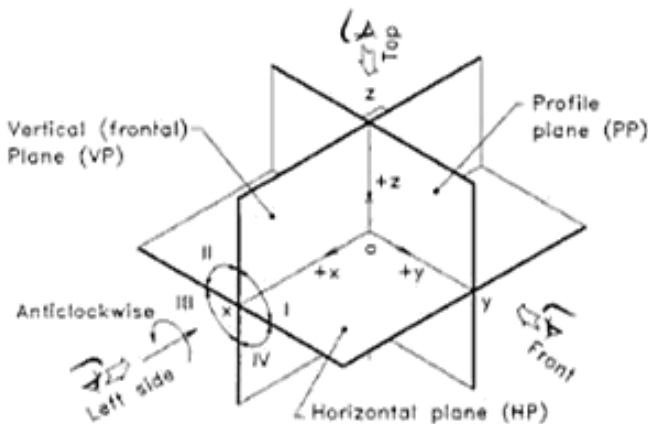

Fig.9.1 Three planes of projection forming eight spaces-octants (anticlockwise system).

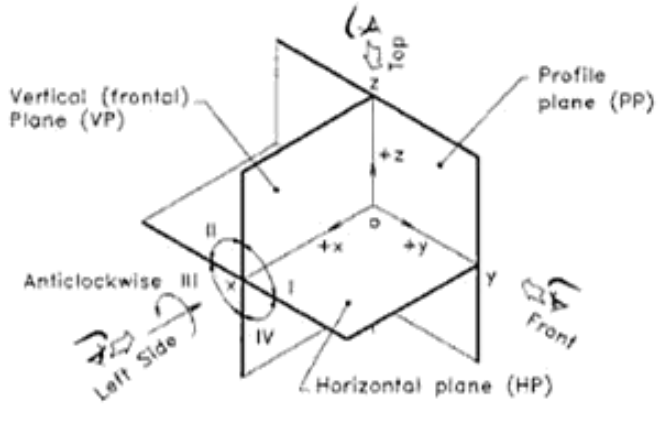

Fig.9.2 The four quadrants for orthographic projection left side view (anticlockwise system).

Urheberrechtlich geschütztes Material

First Angle Projection

In first angle projection the object (say, a vertical cylinder) is assumed to be placed in the first angle (quadrant) as shown in Fig. 9.3. Then the object is viewed from the front side as well as top side in a direction perpendicular (orthogonal) to VP and HP respectively. The views are projected on VP and HP

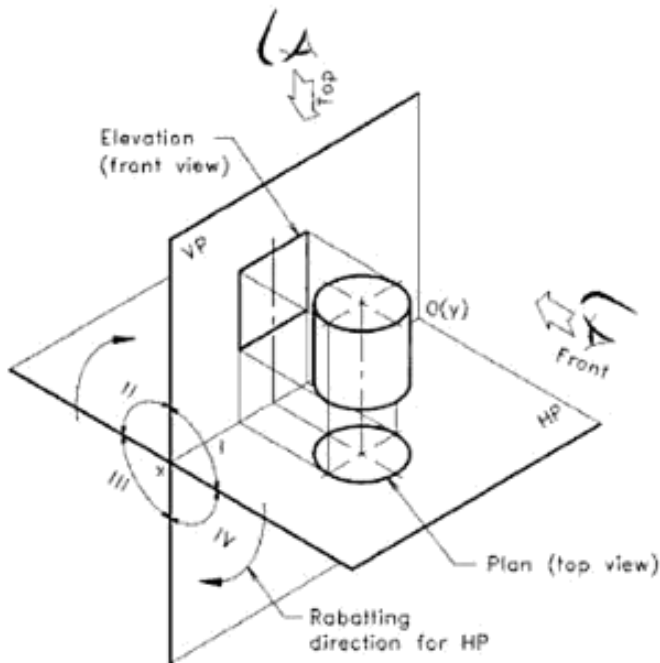

Fig. 9.3 Principal planes with an object in the first quadrant (first angle projection).

in order to get the front view (elevation) and top view (plan) respectively. After projecting the views, the horizontal plane, HP is rotated (rabatted) about the reference line ox as indicated by the arrows, so that the horizontal plane coincides with the vertical plane VP. Now the two views are seen in a single vertical plane, i.e., in the plane of the drawing sheet, as shown in Fig. 9.4.

Third Angle Projection

In the third angle projection, the object (cylinder) is assumed to be placed in the third quadrant and is viewed from the same front, top sides orthogonally (see Fig. 9.5). Note that, the front and top views are seen through the transparent planes. The two views are projected on VP and HP. After rotating (rabating) the planes as done in the previous case, the front

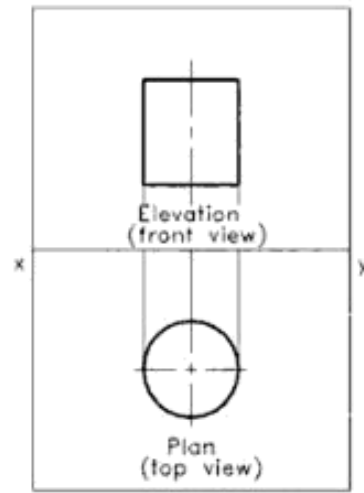

Fig. 9.4 First angle projections of a vertical cylinder.

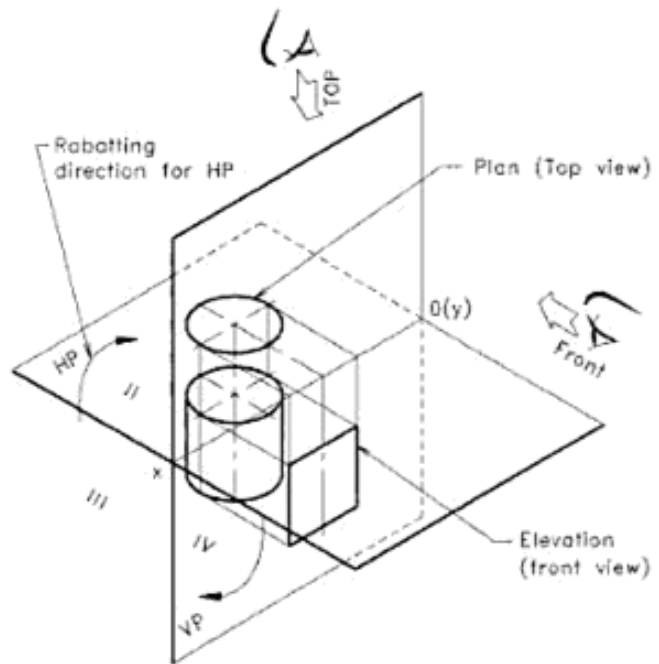

Fig. 9.5 Principal planes with an object in the third quadrant (third angle projection).

and top views of the cylinder are obtained as shown in Fig. 9.6. It is to be noted that the views are the same as that of first angle projection but the location of views are interchanged in the third angle projection.

ISO Symbol to Indicate the Angle of Projection

While drawing orthographic views on a drawing sheet, the

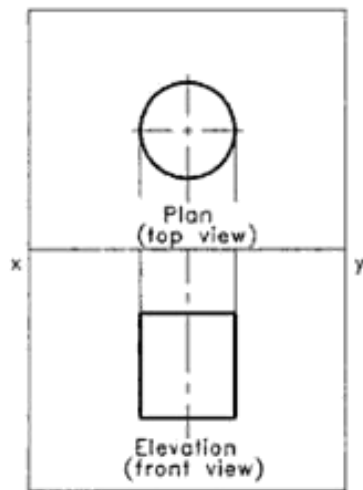

Fig. 9.6 Third angle projections of a vertical cylinder.

method of projection (First angle or third angle) should be indicated using symbols inside the title block. The symbol recommended by ISO as well as Bureau of Indian Standards for the first angle projection is shown in Fig. 9.7. The symbol shows two views of a frustum of a cone lying in the first quadrant keeping its axis horizontal.

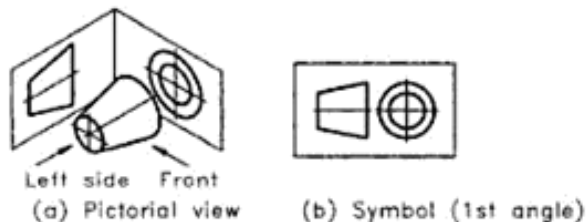

Fig. 9.7 Symbol for first angle projection.

In third angle projection the same frustum of cone is placed horizontal in the third quadrant and the views are obtained as shown in Fig. 9.8. Here, the end view as circles are obtained on the left side of the front view.



Fig. 9.8 Symbol for third-angle projection.

Bureau of Indian Standards has recommended first angle projection method for the preparation of engineering drawings of objects. USSR and other East European countries coming under ISO, follow first angle projection method, while USA follows third angle projection. In UK, both the methods of projection are used.

It may be noted that both the second angle and fourth angle methods of projection are not in use for objects,

because the top and front views get superimposed, when the horizontal plane is rotated in the clockwise direction. However, projections of points and lines are drawn after placing them in all the four quadrants. Hence, an engineering student must study and practice the projections of points and lines placed in all the four quadrants.

9.3 THE PRINCIPLE OF ORTHOGRAPHIC PROJECTIONS OF A POINT ON HP AND VP

Conversion of a Solid to a Point

A solid (say a vertical cylinder) is formed by three-dimensions measured in the three mutually perpendicular directions. If one of the dimensions (say height) is made zero, the object is converted into a two-dimensional plane (circular lamina). Out of the two remaining dimensions, if one more dimension is reduced to zero, the plane is changed into a line. Lastly, if the remaining dimension is also reduced to zero, the line is shortened into zero length, and forms a point. Hence, a point in three-dimensional geometry may be considered as the smallest, dimension-less form of a solid, which can be situated any where in the space. In orthographic projection, this dimensionless object is specified by its location only with respect to the three principal planes VP, HP and PP. The point may be situated in any of the four quadrants (angles) or may lie in the principal planes.

Drawing of a Point

A point-object is represented by a dot in a drawing. Assume that a point-object P is placed in the first quadrant (above HP and in front of VP) as shown in Fig. 9.9. For simplicity, the

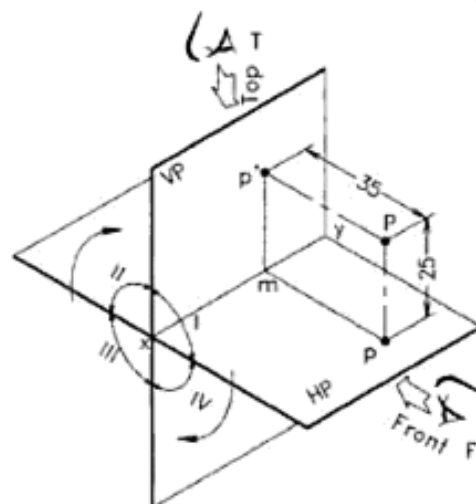

Fig. 9.9 Principal planes with point P in the 1st quadrant.

profile plane PP is not considered here. View the point P from the front and top sides orthogonally. Project the views to the VP and HP respectively by dropping projectors perpendicular to the reference planes. The point of intersection of the projector with the surface of plane is the projection of the point on that plane. Here, the front view on VP is named as p' , and the top view on HP is named as p .

After marking the views and the projectors mp' and mp on the planes, the HP is rabatted (rotated) clockwise about the reference line xy to bring it in the same plane of VP. Now the projection planes will be seen as in Fig. 9.10. The line xy represents the intersection of HP and VP. The rectangles representing the planes are not shown in the final projection form. Figure 9.11 shows the final form of projections of point P situated in the first quadrant.

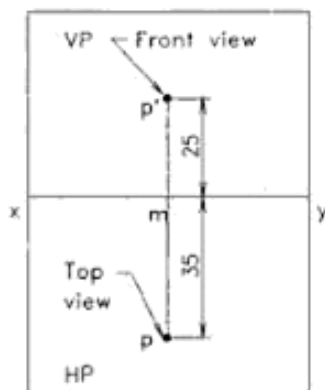

Fig. 9.10 Principal planes with the projected images of point P.

9.4 CONVENTIONAL REPRESENTATION OF VIEWS

In order to distinguish between the projected points, lines, objects, projection lines, etc. of views, certain conventional representations are followed in orthographic projections of solids, similar to that of a language. These conventional representations are obeyed internationally and a variation will be treated as a spelling or grammar mistake in the graphics' language. The conventional representations, relevant to the projections of points, are given below:

1. The actual point is represented by the capital letters as seen in the pictorial view (Fig. 9.9).
2. The top view points are represented by small (lower case) letters such as a, b, c , etc. The front view points are represented by small letters with single primes (dashes) as a', b', c' , etc. while the side view points are represented by small letters with double primes (dashes) as a'', b'', c'' , etc.

3. The planes of projection are assumed to be transparent as well as endless; so that their boundaries are not shown in projections. But the intersection line of HP and VP is shown in geometrical drawings as the reference line xy . Thin line and lower case letters are used for this.
4. The projectors are usually shown in orthographic projections of solids. Thin continuous (Type B) lines are used to draw them. Projection lines are drawn always perpendicular to the reference line xy , because it is orthographic projection.
5. The object is drawn using thick (Type A) lines while all the remaining lines are drawn as thin. For the representation of a point-object, a thick dot (say, 1 mm) may be used (see Fig. 9.11).

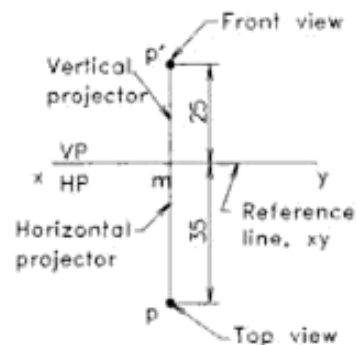

Fig. 9.11 Projections of point P in the 1st quadrant.

9.5 VISUALIZATION OF THE REFERENCE PLANES

To locate the projections of points and lines in the front and top views with respect to the reference line xy , a student may visualize the VP and HP in the following manner.

Refer Fig. 9.12(a). To mark the front view, assume that you are looking at the reference planes from the front side F . Now HP coincides with xy line so that, anything above the xy line means *above HP* and that below the xy line means *below HP*. To get a physical concept, HP (xy line) may be interpreted as a floor with a tree growing above (upwards) and the root growing below (downwards) [see Fig. 9.12(b)]. Similarly, if you are looking from the top side T , the VP coincides with xy line, so that anything *in front of VP* is in front of xy line and that *behind VP* means behind xy line. Here, the VP (xy line) may be interpreted as a wall with a jet plane getting ready to takeoff [see Fig. 9.12(c)]. The Jet moves forward from the VP (wall) while the exhaust gas moves backward. If the two views are combined, Fig. 9.12(d) is obtained.

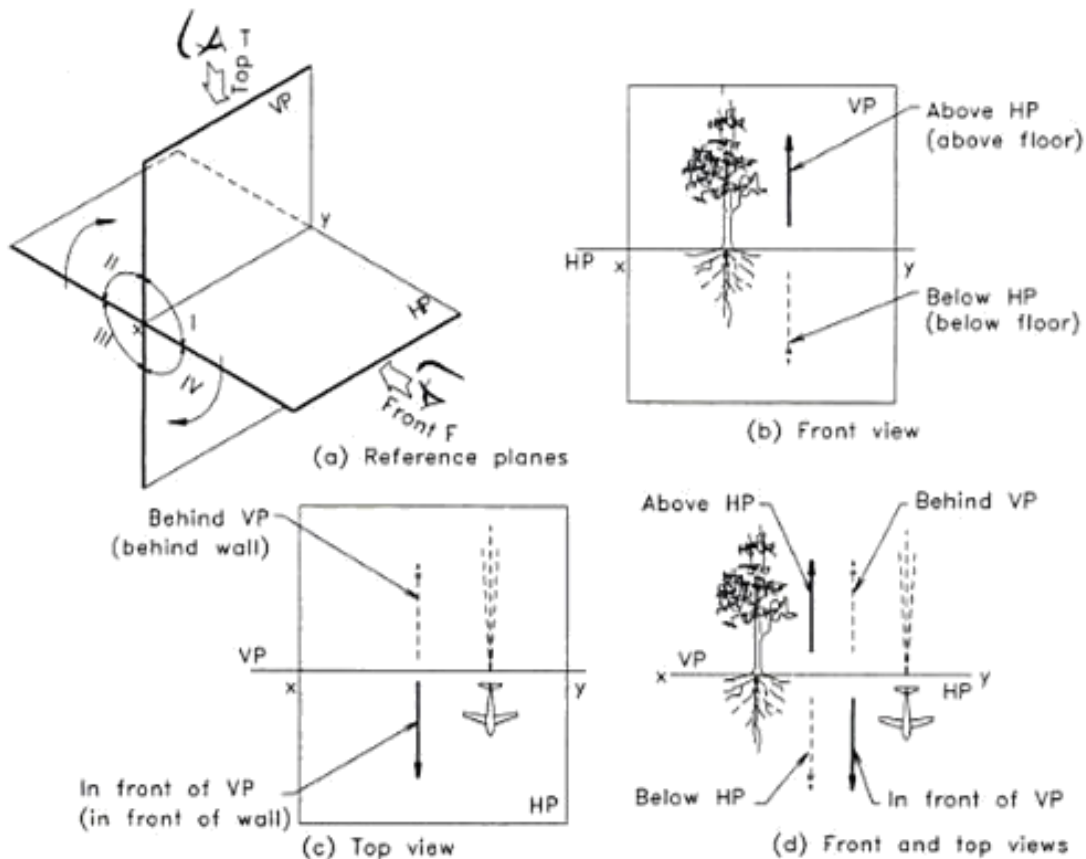

Fig. 9.12 Visualization of principal planes.

It is to be noted that the same xy line is representing the HP (floor) in the front view and VP (wall) in the top view. This makes a little confusion to a beginner. To overcome this, think about a tree standing on the floor (HP) while considering front view and mark the above as well as below distances from HP (xy line), the floor. Similarly think about the jet staying in front of the wall (VP) while considering the top view and mark the front well as behind distances from VP (xy line), the wall.

Meaning of xy line in projection

For all front views, xy line represents the elevation of HP (floor) so that, above xy line means above HP and below xy line means below HP. For all top views, xy line represents the plan of VP (wall) so that, in front of xy line means in front of VP and behind xy line means behind VP.

9.6 PROJECTIONS OF A POINT IN THE FIRST QUADRANT

When a point is situated in the first quadrant, its front view

will be above the xy line and the top view will be below the xy line. Refer to Figs. 9.9 and 9.11. The following example explains the method of solution.

Example 9.1

A point 'A' is 36 mm above HP and 30 mm in front of VP. Draw its projections.

Refer to Fig. 9.13.

1. Draw a horizontal thin line to represent the reference planes and mark xy at the ends.
2. To locate the front view of A, assume that xy line represents the elevation of HP (floor). Then draw the vertical projector ma' using a thin continuous line and mark off 36 mm above xy , as above HP. Here, a' is the front view of the point A.
3. To get the top view, assume that xy line represents the plan of VP (wall). Extend the vertical projector from m to a using thin line, so that ma is 30 mm in front of xy line, i.e., in front of VP. Here, a is the top view of point A.

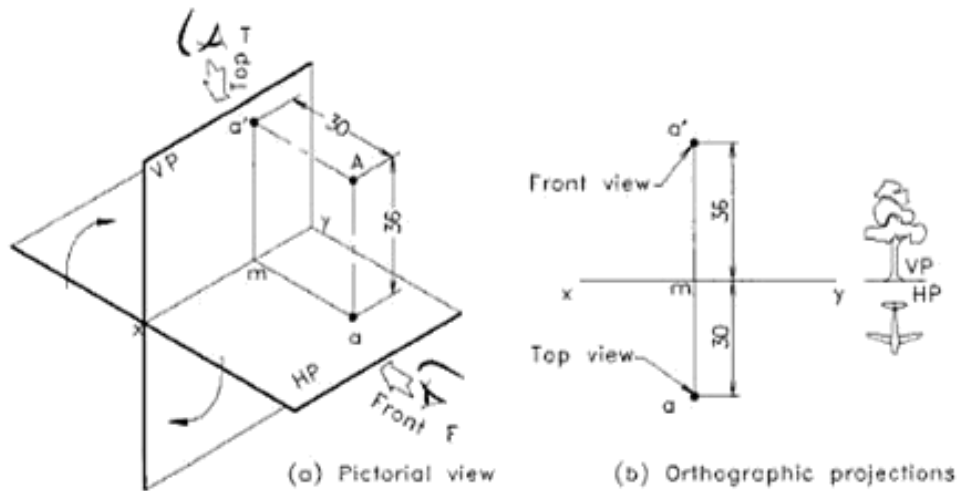

Fig. 9.13 Projections of a point in the 1st quadrant.

- Place thick dots at a' and a . Write the given dimensions as shown in figure to complete the drawing.

9.7 PROJECTIONS OF A POINT IN THE THIRD QUADRANT

In engineering graphics, points and lines have the freedom to occupy any quadrant irrespective of the angle of projection. The location of a point B in the third quadrant is shown in Fig. 9.14(a). The orthographic projections are given in Fig. 9.14(b). Here, the point B is situated below HP, so the front view b' is located below the xy line. Similarly, the point is behind VP, therefore the plan view b is behind the xy line.

Example 9.2

A point B is located 32 mm behind VP and 22 mm below HP. Draw its orthographic projections.

Refer to Fig. 9.14.

- Draw a horizontal thin line to represent the reference planes and name it xy .
- To locate the front view of B, assume that the xy line represents the elevation of HP (floor). Draw the vertical projector mb' , 22 mm below xy i.e., below HP. Locate the front view of point B as b' using a thick dot.
- To locate the top view of B, assume that the xy line represents the plan of VP (wall). Extend the projector from m to b so that, mb is 32 mm behind xy .

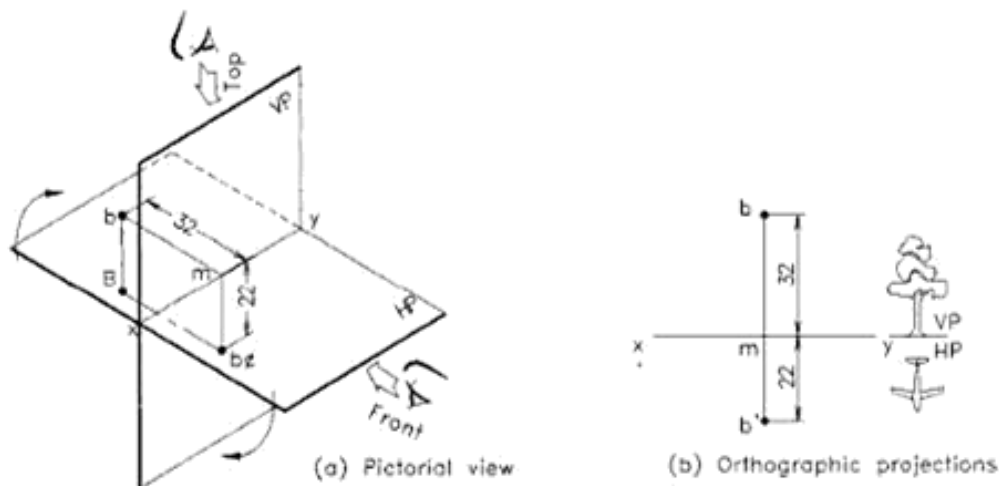

Fig. 9.14 A point in the third quadrant.

line i.e., behind VP. The line mb represents the horizontal projector. Locate the top view of point B as b by a thick dot. Write the given dimensions as shown in the figure in order to complete drawing.

9.8 PROJECTIONS OF POINTS IN ALL THE FOUR QUADRANTS

If an object is placed in the second or fourth quadrant, the orthographic projections of them will be overlapping. This happens due to the rotation of the HP about xy line in the clockwise direction to align with the VP. Hence, the second and fourth angle (quadrant) projection is not applicable to objects. However, for points and lines, this limitation is not considered. Fig. 9.15(a) shows the pictorial view of a point C, placed in the second quadrant. When the HP is rotated, the two projections will come to the same side of xy line. The final view will be as shown in Fig. 9.15(b). Similarly, for a point D located in the fourth quadrant, the projections will be as seen in the Fig. 9.16(a) and will be falling below the xy line as shown in Fig. 9.16(b). The following examples give the projections of points, situated in the four quadrants.

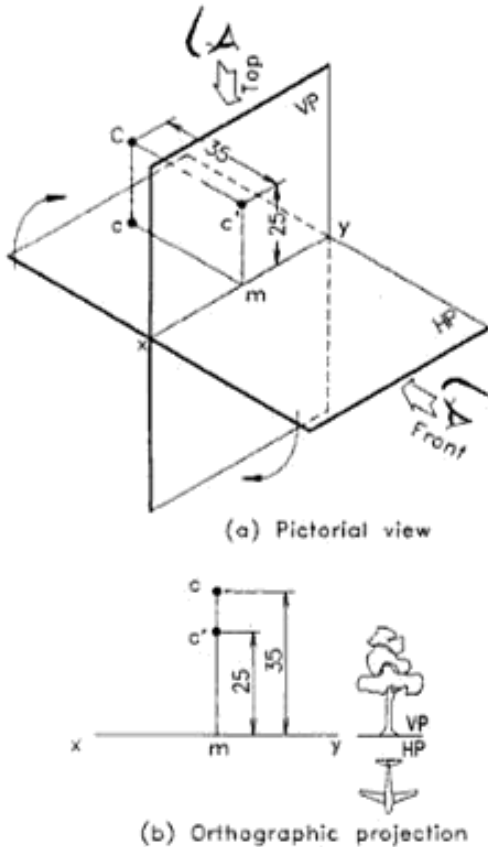

Fig. 9.15 A point in the second quadrant.

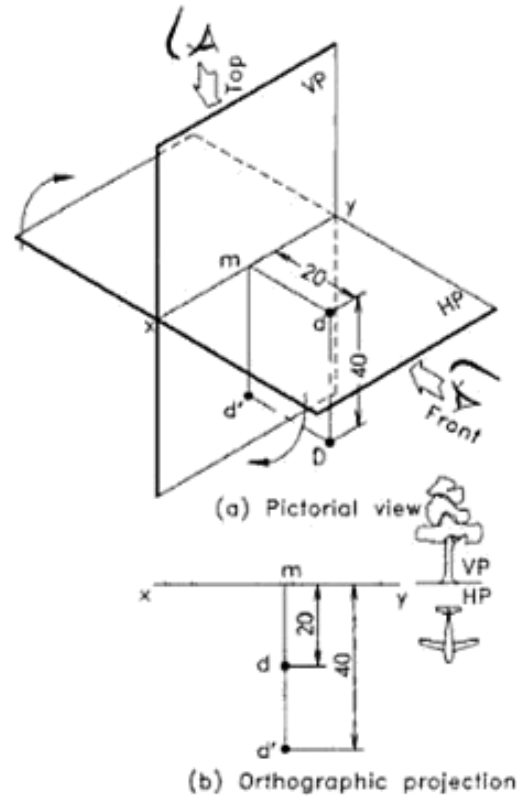

Fig. 9.16 A point in the fourth quadrant.

Example 9.3

A point C is situated 35 mm behind VP and 25 mm above HP. Draw its projections.

Refer to Fig. 9.15.

1. Draw the xy line.
2. To locate the front view of C, assume that the xy line represents the elevation of HP (floor). Draw the vertical projector mc' equal to 25 mm above xy line i.e. above HP.
3. To locate the top view of C, assume that the xy line represents the plan of VP (wall). Draw the projectors mc , equal to 35 mm behind xy i.e. behind the VP as shown in figure.
4. Mark c and c' with thick dots and place the given dimensions. It is seen that points c and c' lie on the same side of the xy line, because the point C is in the second quadrant.

Example 9.4

A point D is situated 40 mm below HP and 20 mm in front of VP. Draw its projections.

Refer to Fig. 9.16.

1. Draw the xy line.
2. Draw the projector md' equal to 40 mm below xy line i.e., below HP (floor).
3. Locate the plan view as d on the projector, so that md is 20 mm in front of xy line i.e., in front of VP (wall).
4. Mark d and d' with thick dots and place the dimensions. Here, the views d and d' lie on the same side of the xy line, because the point is situated in the fourth quadrant.

Example 9.5

The following four points PQRS are situated in the four quadrants. Draw the orthographic projections of them about a single reference line, assuming that their projectors are spaced 30 mm apart horizontally.

- (a) P is 30 mm above HP and 40 mm in front of VP.
- (b) Q is 25 mm above HP and 35 mm behind VP.
- (c) R is 32 mm below HP and 38 mm behind VP.
- (d) S is 36 mm below HP and 15 mm in front of VP.

Refer to Fig. 9.12.

1. Draw the xy line.
2. Draw projectors 30 mm apart, perpendicular to the reference line, on the xy line as shown in the figure. Locate the front view and top view of the points PQRS located in quadrants I, II, III and IV.
3. Mark the location of the points with thick dots and dimension them to complete the drawing.

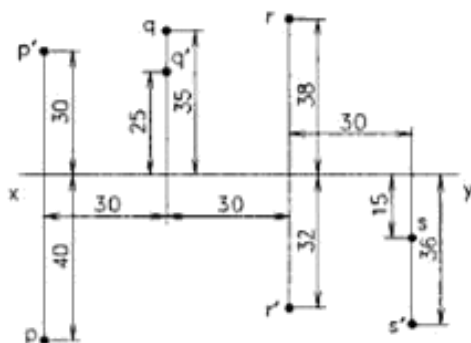

Fig. 9.17 Projections of points in the four quadrants.

9.9 INTERPRETATION OF PROJECTIONS OF POINTS

A student in engineering graphics should develop the capacity to interpret (read) the views and understand the

information contained in them. This is a reverse process of what was explained in the previous examples.

Example 9.6

Figure 9.18 gives the projections of points M, N, O and P. Interpret them and determine the positions of the points with respect to the principal planes.

Print the answer using capital letters as given below:

1. Point m is 30 mm above HP and 20 mm in front of VP.
2. Point n is 35 mm below HP and 15 mm in front of VP.
3. Point o is in the HP and 26 mm behind VP.
4. Point p is in both HP and VP.

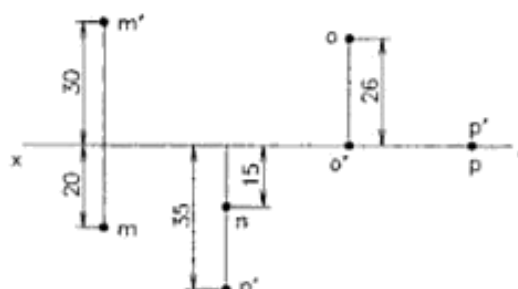

Fig. 9.18 Projections of points in the four quadrants.

9.10 PROJECTIONS OF POINTS ON HP, VP AND PP

A point is fully located in the space, when the distance from the profile plane is also marked in addition to that from HP and VP. Figure 9.19 shows pictorial view of point P located in the first quadrant. Here, o is the intersection point of the three planes called the *origin*. The intersection line of VP and HP is marked as ox , that of PP and HP is marked as oy and the intersection line of PP and VP is marked as oz . To get the projection of P on profile plane, the point is viewed from the left side and projected perpendicular to PP. The view on PP is named as p'' . To bring the three planes aligned to VP, the HP is rabatted about xo line and PP is rabatted about zo line resulting the opening of the first quadrant to a single plane. The pictorial view is shown in Fig. 9.20 and the front view in Fig. 9.21. Here, note that the three planes overlap each other. The final view of the projections is shown in Fig. 9.22. Since the distance from the PP is not given, the front and top views may be placed at any convenient distance from oz line.

Note that the horizontal line xo is extended to y and the vertical line zo is extended to y_1 to represent the intersection of the three planes. Here, lines oy and oy_1 are the split form of

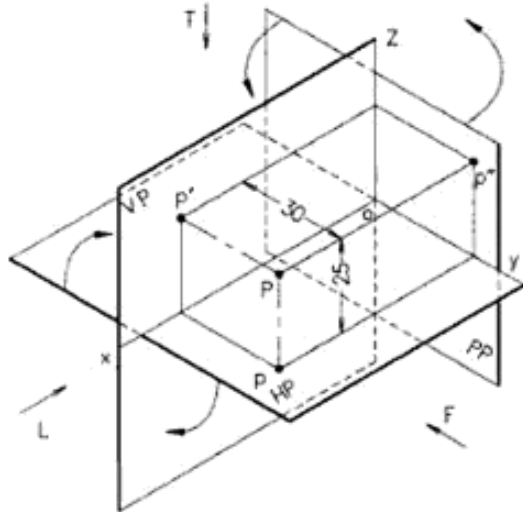

Fig. 9.19 Three principal planes with point P in the 1st quadrant (pictorial view).

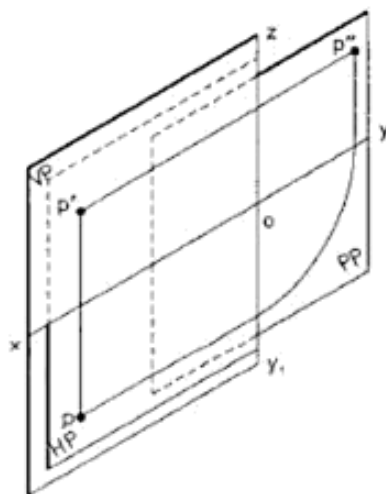

Fig. 9.20 Three principal planes with projected views of point P (pictorial view—after rabation).

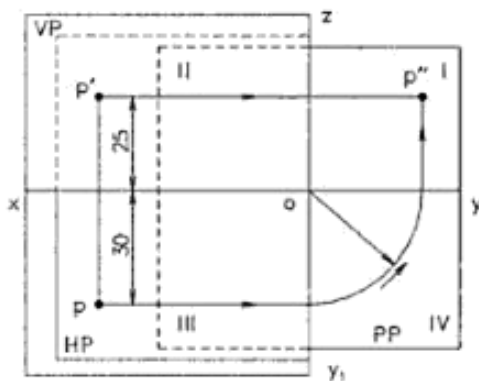

Fig. 9.21 Three principal planes with projected views of point P (orthographic view).

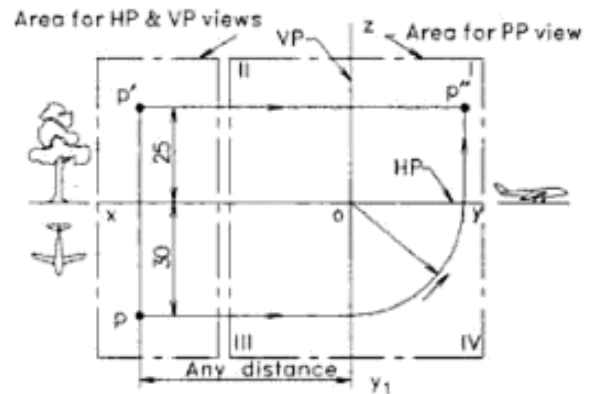

Fig. 9.22 Three orthographic views of point P in the 1st quadrant.

the intersection line oy marked on the pictorial view of planes in Fig. 9.22. It is to be noted that if a profile view is not required, xoy line is reduced as xy line and the zoy_1 line is eliminated for simplicity of presentation.

Example 9.7

Draw three views of a point P located in the first quadrant and dimension them as per BIS. The point P is 25 mm above HP and 30 mm in front of VP.

Refer to Fig. 9.22.

1. Draw the xoy line horizontal and the zoy_1 line vertical through the origin o as shown.
2. Mark front and top views p' and p of point P, after drawing the projectors at a convenient distance from zoy_1 line.
3. Draw horizontal projector through p to meet line oy_1 and rotate it anticlockwise about o to oy . Then project the line upwards to meet the horizontal projector drawn from p' , to get the point p'' in the first quadrant.
4. Dimension the views as per BIS.

Example 9.8

Point A is located in the third quadrant. The distance from HP is 30 mm and that from VP is 20 mm. Draw projections of the point on HP, VP and PP.

Refer to Fig. 9.23.

1. Draw the xoy line horizontal and the zoy_1 line vertical through the origin o as shown.
2. Mark front and top views a' and a , after drawing the projectors at a convenient distance from the zoy_1 line.
3. Draw horizontal projector through a to meet the line oz and rotate it anticlockwise about o to ox .

Then project the line downwards to meet the horizontal projector drawn from a' , to get the point a'' in the third quadrant.

4. Dimension the views and complete the drawing.

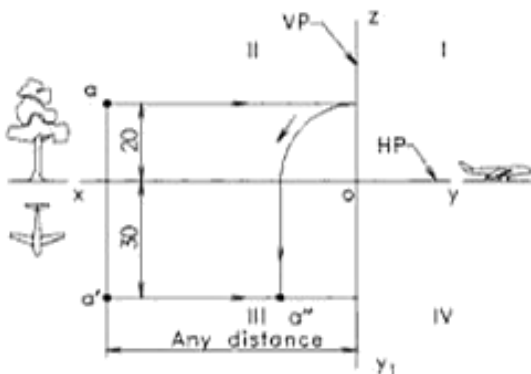

Fig.9.23 Three orthographic views of point A in the 3rd quadrant.

Example 9.9

Point B is located in the second quadrant. The distances from HP and VP are 28 mm and 18 mm respectively. Similarly point C is located in the fourth quadrant. The distances from HP and VP are 30 mm and 15 mm respectively. Draw projections of the points on HP, VP and PP. The distance between points along xy line may be taken as 20 mm.

Refer to Fig. 9.24.

1. Draw the xoy line horizontal and the zo_1y_1 line vertical through the origin o as shown.
2. Mark front and top views b' and b , after drawing the projectors at a convenient distance from the zo_1y_1 line.
3. Draw horizontal projector through b to meet the line oz and rotate it anticlockwise about o to ox . Then project the line upwards to meet the

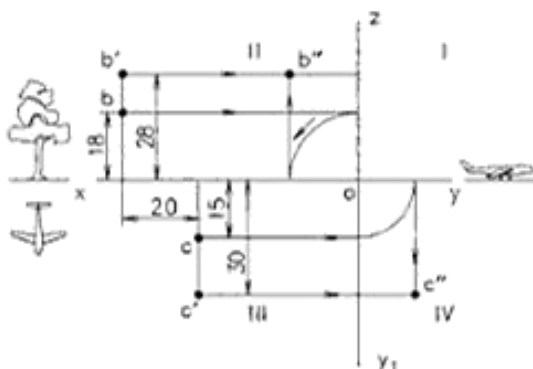

Fig.9.24 Three orthographic views of point A in the 3rd quadrant.

horizontal projector drawn from b' , to get the point b'' in the second quadrant.

4. Similarly, mark the front and top views c' and c , after drawing the projectors at a distance of 20 mm from projection line bb' as shown in the figure.
5. Draw horizontal projector through c to meet the line oy_1 and rotate it anticlockwise about o to oy . Then project the line downwards to meet the horizontal projector drawn from c' , to get the point c'' in the fourth quadrant.
6. Dimension the views and complete the drawing.

Example 9.10

A point D is located in the first quadrant. The shortest radial distance line drawn from the point D to the intersection of HP and VP has 40 mm length and is inclined at 60° to HP. Draw front and top views of the point D.

Refer to Fig. 9.25.

1. Draw the xoy line horizontal and the zo_1y_1 line vertical through the origin o as shown.
2. Mark the left side view d'' on PP, after drawing a 60° inclined radial line of length 40 mm from origin o , in the first quadrant as shown in the figure.
3. Draw a vertical projector ($d'd$) at a convenient distance from the zo_1y_1 line. Then draw a horizontal projector through d'' to meet the vertical projector at d' .
4. Draw vertical projector through d'' to meet the line oy and rotate it clockwise about o to oy_1 . Then project from the point horizontally to meet the vertical projector drawn from d' , to get the point d .
5. Dimension the views and complete the drawing.

Example 9.11

The shortest distance of a point E to the intersection line of HP and VP is 36 mm and the point is 20 mm above HP. Draw the front and top views, if the point is in the second quadrant.

Refer to Fig. 9.26.

1. Draw the xoy line horizontal and the zo_1y_1 line vertical through the origin o as shown.
2. Mark the left side view e'' on PP, after drawing a horizontal line at a distance of 20 mm above HP and cutting an arc of radius 36 mm from origin o , in the second quadrant as shown in the figure.
3. Draw a vertical projector at a convenient distance from the zo_1y_1 line. Then draw a horizontal projector through e'' to meet the vertical projector at e' .
4. Draw vertical projector through e'' to meet the line ox and rotate it clockwise about o to meet oz . Then project from the point horizontally to meet the vertical projector drawn from e' , to get the point e .
5. Dimension the views and complete the drawing.

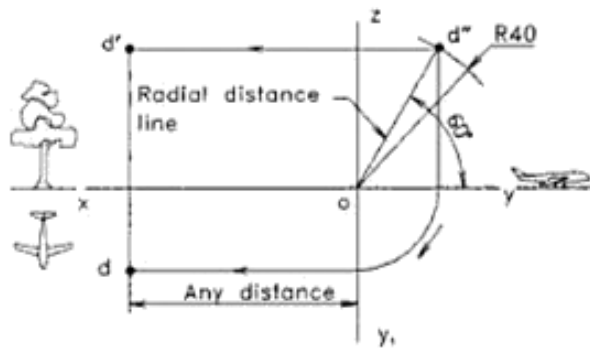

Fig. 9.25 Three orthographic views of point D in the 1st quadrant.

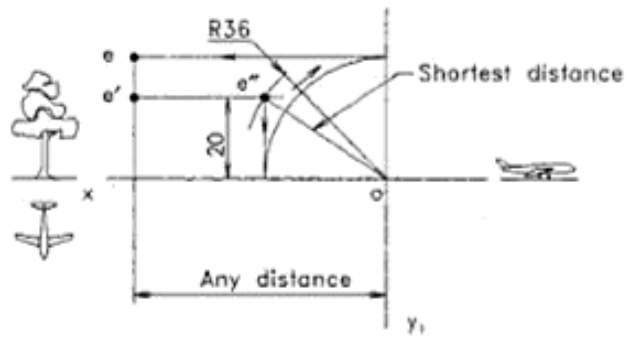

Fig. 9.26 Three orthographic views of point E in the 2nd quadrant.

EXERCISES

Projections on HP and VP

1. A point K is 35 mm above HP and 25 mm in front of VP. Draw the orthographic projections.
2. A point L is located 30 mm below HP and 36 mm behind VP. Draw the projections of point L.
3. Point M is situated 32 mm behind VP and 22 mm above HP. Draw its projections and dimension them.
4. A point N is situated 20 mm below HP and 40 mm in front of VP. Draw the projections.
5. Draw the projections of the following points. Take the distance between the projectors as 25 mm:
 - (i) Point A is 20 mm above HP and 42 mm in front of VP.
 - (ii) Point B is 35 mm below HP and 20 mm in front of VP.
 - (iii) Point C is 20 mm above HP and 36 mm behind VP.
 - (iv) Point D is 42 mm below HP and 25 mm behind VP.

Dimension the figures as per BIS.

6. Figure 9.27 gives the orthographic projections of certain points. Interpret them and write the positions of

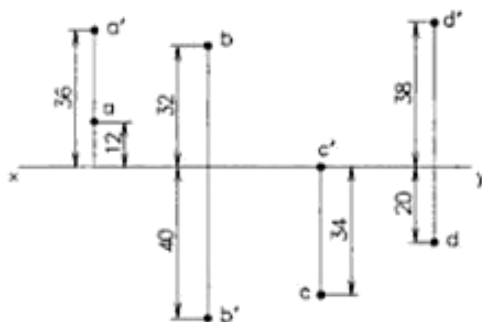

Fig. 9.27

the points with respect to VP and HP using 4 mm capitals.

7. Draw projections of the following points and show the dimensions as per BIS. The distance between the projectors is 30 mm.
 - (a) Point P is in the VP and 34 mm below HP.
 - (b) Point Q is in the HP and 32 mm behind VP.
 - (c) Point R is in both the HP and VP.
 - (d) Point S is in the third quadrant and 35 mm away from both HP and VP.
8. The orthographic projections of certain points are shown in Fig. 19.28. Determine their positions with respect to the reference planes and print them using 4 mm letters.

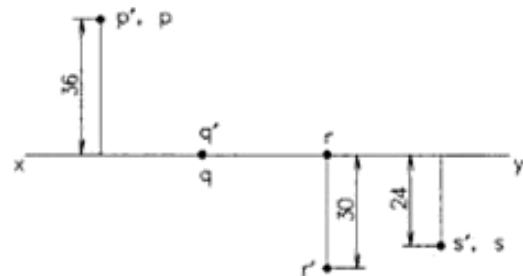

Fig. 9.28

Projections on HP, VP and PP

9. Draw three views of a point Q located in the first quadrant and dimension them as per BIS. The point Q is 35 mm above HP and 20 mm in front of VP.
10. Point E is located in the third quadrant. The distance from HP is 32 mm and that from VP is 26 mm. Draw projections of the point on HP, VP and PP.

11. Point F is located in the second quadrant. The distances from HP and VP are 38 mm and 28 mm respectively. Similarly, point G is located in the fourth quadrant. The distances from HP and VP are 40 mm and 25 mm respectively. Draw projections of the points on HP, VP and PP. The distance between points along xy line may be taken as 30 mm.
12. A point H is located in the first quadrant. The shortest radial distance line drawn from the point H to the intersection of HP and VP has 50 mm length and is inclined at 30° to HP. Draw front and top views of the point H.
13. The shortest distance of a point J to the intersection line of HP and VP is 46 mm and the point is 25 mm above HP. Draw the front and top views, if the point is in the second quadrant.
14. A point M is lying in the first quadrant. The shortest distance of the point from xy line is 55 mm. If the point is 30 mm above HP, draw its projections.

Urheberrechtlich geschütztes Material

Projections of Straight Lines

A straight line may be defined as the *locus* of a point which moves along the shortest path joining two given points. It may also be defined as the locus of a point which moves linearly. A line in this chapter is considered to be a straight line unless the shape is specified.

The shape of an object is formed by different surfaces. A geometrical surface is formed by rotating or moving a straight line in different forms. Various machine parts, concrete structures, etc., are formed by such geometrical shapes. Hence, clear grasping of projections of lines is a necessary requirement for engineers to understand the three-dimensional shapes, positions, etc. and solve the related problems.

10.1 CLASSIFICATION OF LINE POSITIONS

A line may be placed in infinite number of positions with reference to the vertical and horizontal and profile planes. These positions may be classified according to the inclination of the line to the reference planes and the quadrants in which it is placed. The classification based on inclination is given in Fig. 10.1. They are:

- (a) Line parallel to both the reference planes
- (b) Line perpendicular to one of the reference planes
- (c) Line inclined to HP but parallel to VP

- (d) Line inclined to VP but parallel to HP
- (e) Line inclined to both HP and VP (oblique line)
- (f) Oblique line parallel to PP

The classification of lines, based on the quadrants in which they are placed is:

- (a) Line placed in one of the four quadrants
- (b) Line contained in one of the planes
- (c) Line placed in two quadrants
- (d) Line placed in three quadrants

Figure 10.2 gives the pictorial view of the above classes of lines and their orthographic projections.

As per ISO as well as Bureau of Indian Standards, first angle projection has to be followed for all engineering drawings. But as mentioned earlier, points and lines are free from this rule. A student of Engineering Graphics has to study the projections of lines, placed anywhere in the four quadrants.

10.2 LINE PARALLEL TO BOTH THE REFERENCE PLANES

Figure 10.3(a) gives the pictorial view of a line AB placed parallel to both the reference planes. If the points A and B are projected to the vertical and horizontal planes, the front view (elevation) $a'b'$ and top view (plan) ab are obtained on the

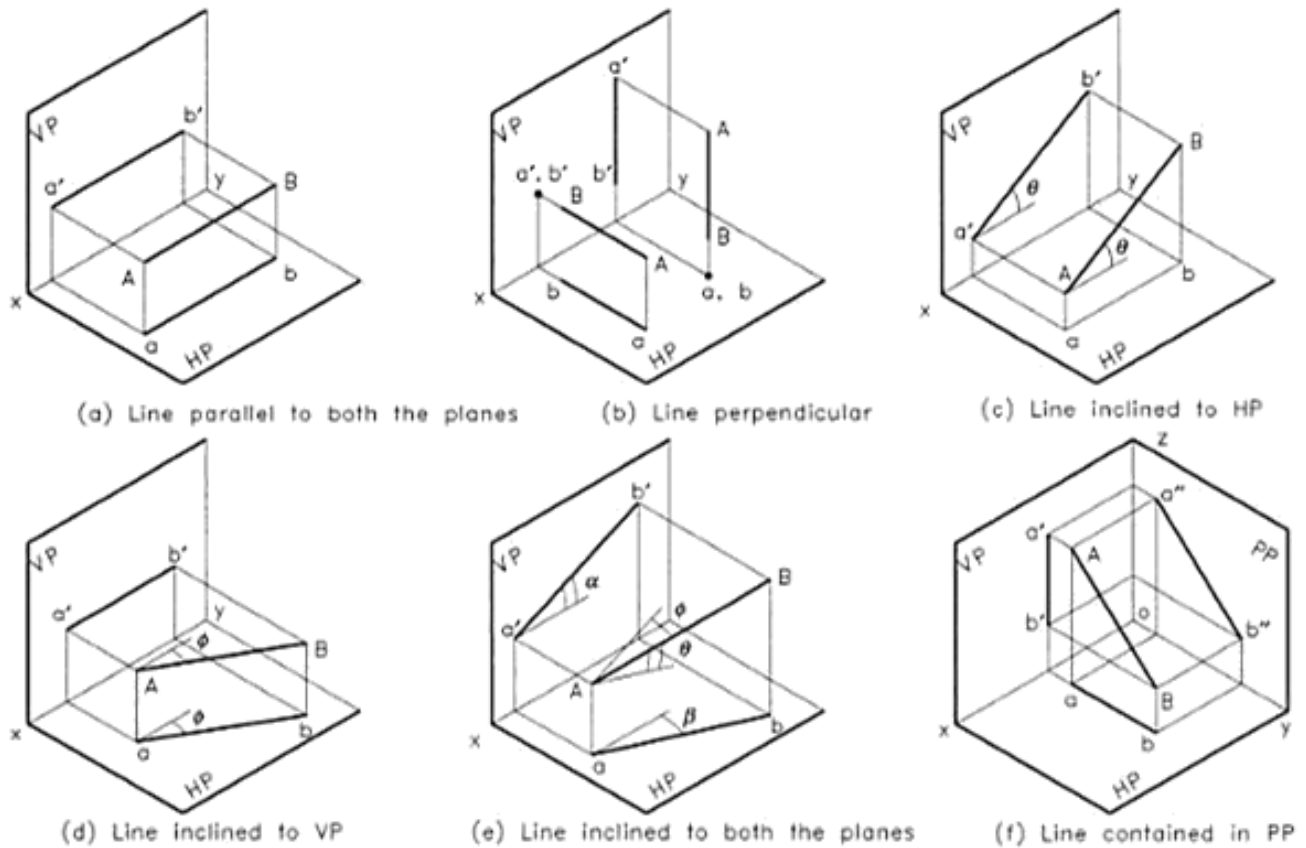

Fig. 10.1 Line positions by inclination.

respective planes. After rotating the HP, the view will occupy a position shown in Fig. 10.3(b). Here xy line represents the intersection of HP and VP. The two projections of the line can be visualised as did for the projection of the points. Figure 10.3(c) shows the projected views of the line to be presented by a student in his drawing. The following important points may be noted from the views.

1. The line AB is parallel to both the planes, hence the projections $a'b'$ and ab will be having the true length of AB.
2. Since the line is parallel to both the planes, the projections will be parallel to xy line.
3. The lines $a'b'$ and ab represents the projections of the given object, hence they are drawn by using Type A thick (0.5 mm) continuous lines. All the remaining lines are drawn using Type B thin (0.25 mm) continuous lines.
4. The projectors connecting front and top views will be always perpendicular to xy line and are represented by Type B thin (0.25 mm) lines.

Meaning of xy line in projection

For all front views, xy line represents the elevation of HP (floor) so that, above xy line means above HP and below xy line means below HP. For all top views, xy line represents the plan of VP (wall) so that, in front of xy line means in front of VP and behind xy line means behind VP.

Example 10.1

A line AB 50 mm long is parallel to both HP and VP. The point A is 20 mm above HP and the point B is 40 mm in front of VP. Draw its projections.

Refer to Fig. 10.3(c).

1. Draw the xy line.
2. The line AB is in the first quadrant. Since the line is parallel to HP and VP, the projections of the line will be parallel to xy . Draw the line $a'b'$ as front view, 20 mm above xy line (HP) and line ab as top view, 40 mm in front of xy line (VP).
3. The line AB is parallel to both the planes, hence the two projections will have the true length 50 mm. Draw the end projectors perpendicular to xy line.

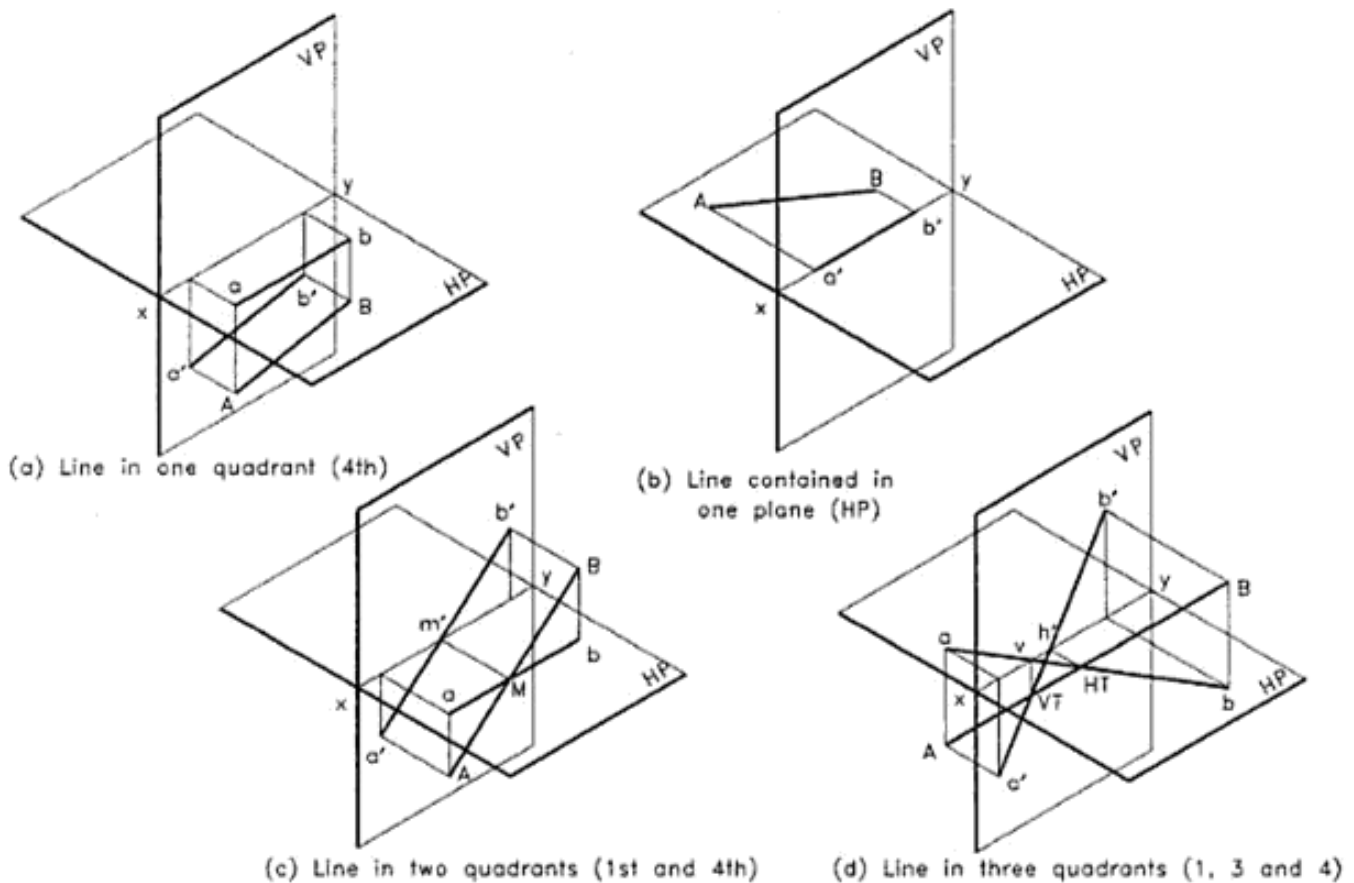

Fig. 10.2 Line positions by quadrant.

4. Finish the views by converting them into thick lines. Name the points and print the given dimensions as shown in Figure 10.3(c).

10.3 LINE PERPENDICULAR TO ONE OF THE REFERENCE PLANES

When a line is perpendicular to one of the reference planes, it will be automatically parallel to the other plane. Figure 10.4(a) shows the pictorial view of a line AB perpendicular to VP. Since the line is perpendicular to VP, its projection of end points a' and b' coincide to form a single point. The line is parallel to HP, so, its projection on HP has the true length. After rabatting the planes, the view will occupy a position as shown in Fig. 10.4(b).

Example 10.2

A 40 mm long line AB is positioned in such a way that it is

perpendicular to VP and the end B is 10 mm in front of VP and 30 mm above HP. Draw its projections, keeping the line in the first quadrant.

Refer to Fig. 10.4.

1. Draw the xy line.
2. The line is perpendicular to VP, hence it is parallel to HP. In the VP, ends a' and b' coincide to form a point. Therefore, draw a line perpendicular to xy line. Locate the front view as a thick point ($a'b'$) at a height of 30 mm above HP (above xy line).
3. Unless and otherwise stated, a line is assumed to be in the first quadrant. So, mark $ab = 40$ mm (true length) on the perpendicular drawn to xy line, such that point b is 10 mm in front of VP (in front of xy line)
4. Convert ab to thick line to represent the plan of AB and note the given dimensions as shown in figure to complete the views.

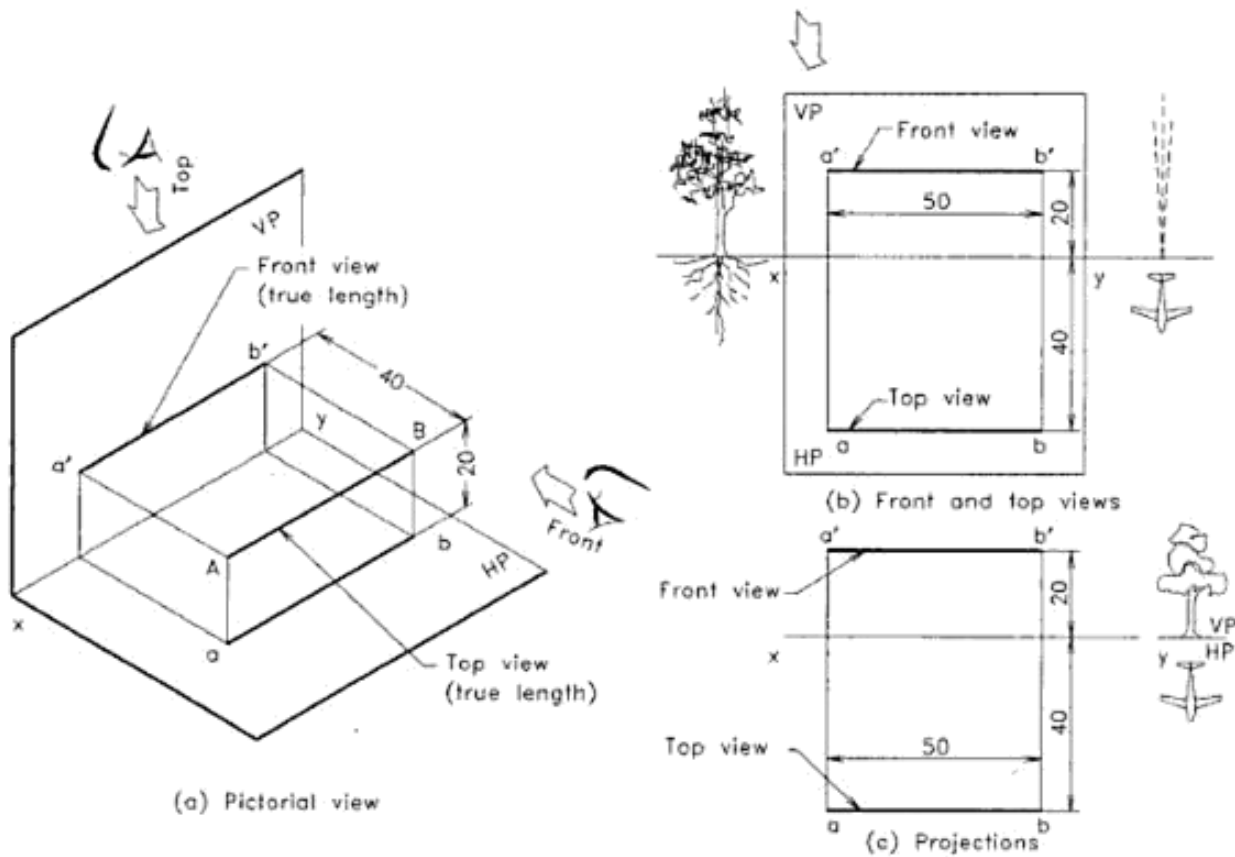

Fig. 10.3 Line parallel to both the planes.

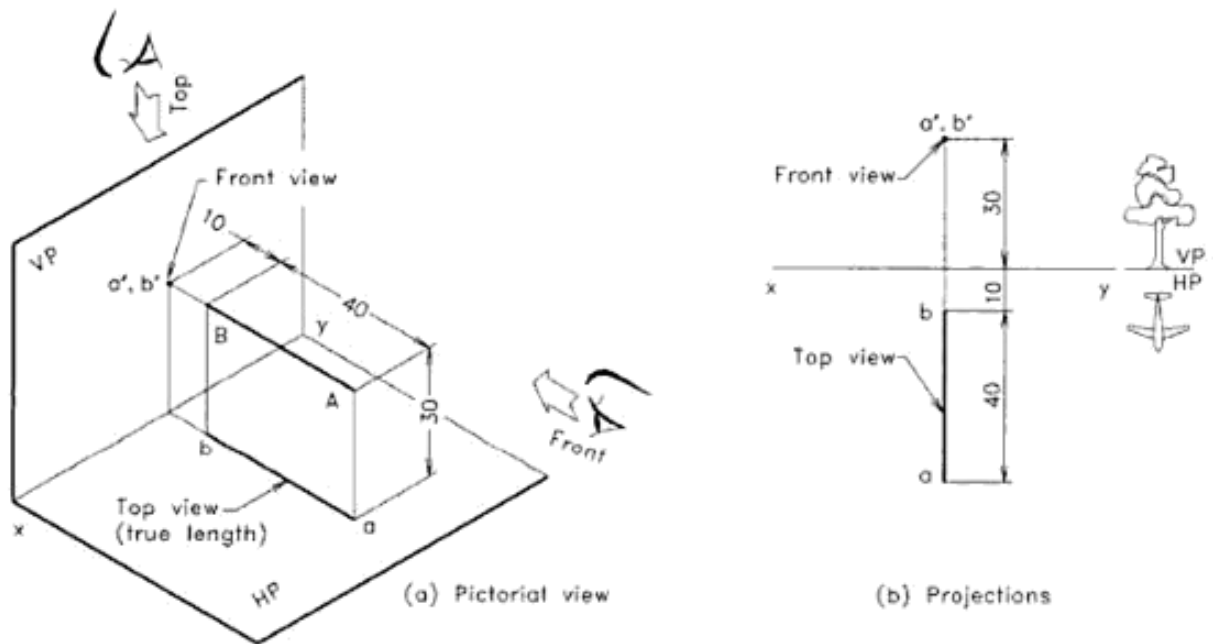

Fig. 10.4 Line perpendicular to VP.

Urheberrechtlich geschütztes Material

Example 10.3

Line CD, 36 mm long is in the first quadrant. End D is 12 mm above HP and 24 mm in front of VP. If the line is perpendicular to HP draw its projections.

Refer to Fig. 10.5.

1. Draw the xy line.
2. As the line CD is vertical, the top view of the points C and D will coincide. Hence, mark a point c, d as top view, 24 mm in front of xy line (VP).
3. The line is vertical means it is parallel to VP and the projection on VP will show the true length. Therefore, draw a projector from c, d , perpendicular to xy line and mark the point d' , 12 mm above xy line (HP) and line $c'd' = 36$ mm.
4. Give appropriate thickness to the lines and place the given dimensions to complete the projections as shown in the figure.

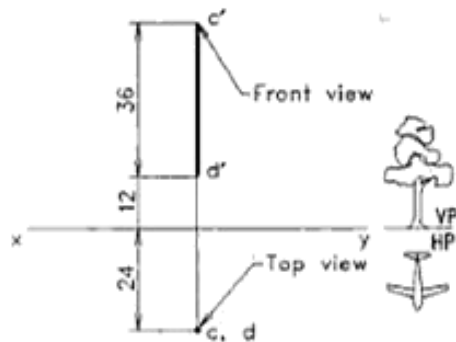
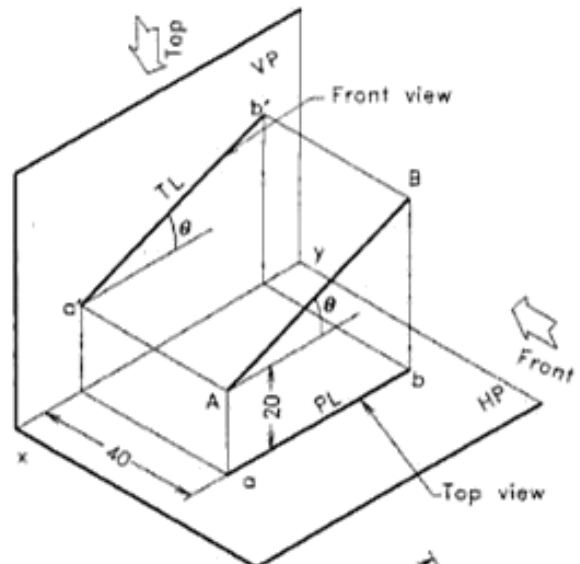

Fig. 10.5 Line perpendicular to VP.

10.4 INCLINED LINE PLACED IN FIRST QUADRANT

When a line is parallel to one of the reference planes and inclined to the other, may be called as *inclined line*. Its projection on the plane to which it is parallel will have the true length (TL) and true inclination (θ or ϕ). Figure 10.6(a) shows the pictorial view of a line inclined at θ° to HP. The projection $a'b'$ on VP has the true length of AB and the true inclination θ° . But the top view ab is parallel to xy and has an apparent length (plan length = PL) less than the true length. Similarly, when a line is ϕ° inclined to VP but parallel to HP, the projection on HP has the true length (TL) and true inclination ϕ° as shown in Fig. 10.7(a). Here the line is contained in the HP. The front view is on xy line and has an apparent length (elevation length = EL) less the true length. From the above two figures the following properties of projections of an inclined line may be noted.



(a) Pictorial view

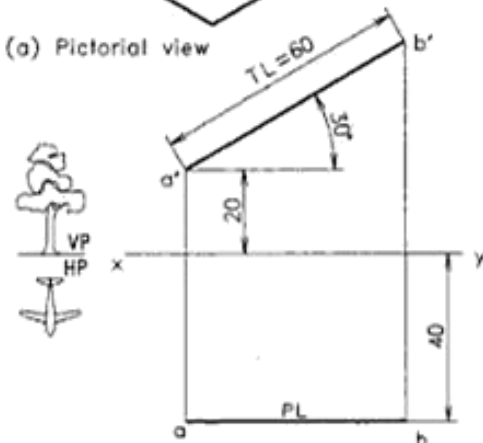

(b) Projections

Fig. 10.6 Line inclined to HP (line in 1st quadrant).

1. The projection on the plane to which the line is parallel will have the true length TL and true inclination θ or ϕ .
2. The projection on the plane to which the line is inclined will have a reduced apparent length PL or EL.
3. If a line is contained in a plane, its projection on the other plane will be on the xy line itself.

Example 10.4

A line AB, 60 mm long is parallel to VP and inclined at 30° to HP. The end A is 20 mm above HP and 40 mm in front of VP. Draw the projections.

Refer to Fig. 10.6.

1. Draw the xy line.
2. Mark points a' and a , 20 mm above HP (xy line) and 40 mm in front of VP (xy line).
3. Draw the 30° inclined line $a'b'$ having a true length 60 mm and place the end projector $b'b$ perpendicular to the xy line.
4. Draw ab parallel to xy to represent the top view.
5. Finish the drawing by giving proper line thickness and print the given dimensions.

Example 10.5

Line CD is inclined at 45° to VP and is contained in HP. The end C is 16 mm in front of VP. Draw the projections of the line, if the true length of line CD is 50 mm.

Refer to Fig. 10.7.

1. Draw the xy line.

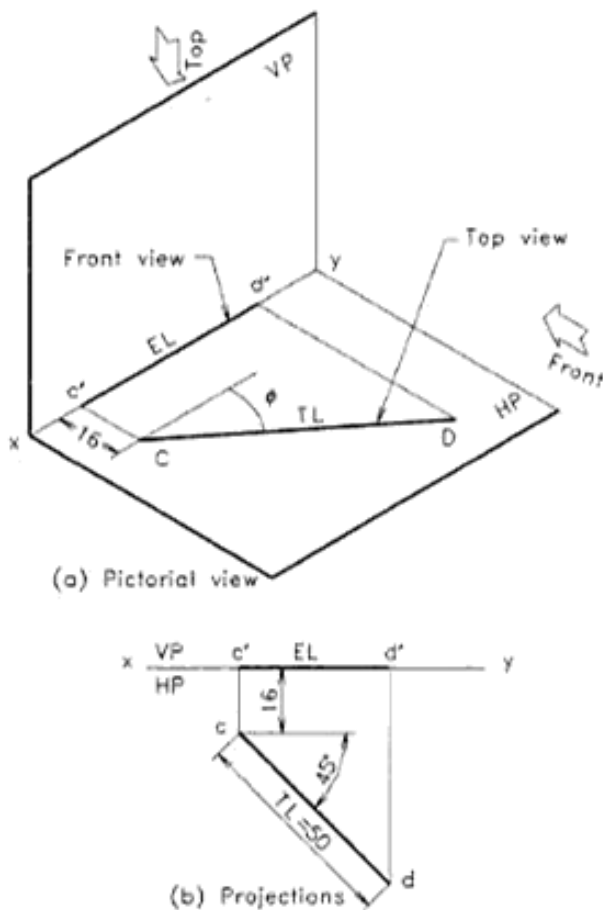

Fig. 10.7 Line inclined to VP (line in 1st quadrant).

2. Locate point c' on xy line (HP) and point c , 16 mm in front of xy line (VP).
3. Draw $CD = 50$ mm, the true length, at 45° to VP (xy line) and insert end projector dd' perpendicular to xy .
4. Draw thick line to represent elevation $c'd'$, on xy .
5. Finish the drawing by giving proper line thickness and print the given dimensions.

10.5 INCLINED LINE PLACED IN ANY ONE OF THE FOUR QUADRANTS

Line inclined to one of the reference planes may be placed in any one of the four quadrants. Such a line can be drawn by marking the end points as is done in the previous problems. The following examples explain the procedure.

Example 10.6

A line MN, has end M 20 mm below and 30° inclined to HP. If the line is 30 mm behind and parallel to VP, draw projections and find its true length. The distance between the end projectors is 60 mm and the line is in the third quadrant.

Refer to Fig. 10.8.

1. Draw the xy line.
2. Locate point m' , 20 mm below HP and m , 30 mm behind VP.
3. Draw $m'n'$ at 30° to HP (xy line) to intersect the vertical projector drawn at 60 mm distance from the projector mm' .
4. Draw line mn (PL) parallel to xy to mark the plan.
5. Measure the true length (TL) of line $m'n'$ and print the answer below the drawing.
6. Finish the drawing by giving proper line thickness and print the given dimensions.

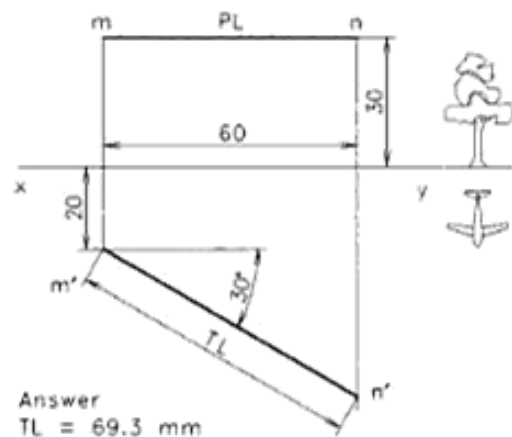

Fig. 10.8 Line inclined to HP (line in 3rd quadrant).

Example 10.7

A line PQ, has end P 26 mm behind VP and on HP. If the line has 80 mm length and parallel to VP, draw projections and find its true inclination and plan length. The end Q is 60 mm above HP and the line is in the second quadrant.

Refer to Fig. 10.9

1. Draw the xy line.
2. Locate point p , 26 mm behind VP and p' on HP.
3. Draw a line $h'h'$, 60 mm above xy (HP) and cut an arc of radius 80 mm from p' to locate q' on line $h'h'$. Now $p'q'$ is the elevation of the line.
4. Draw line pq (PL) parallel to xy to get the plan.
5. Finish the drawing by giving proper line thickness and print the given dimensions.
6. Measure the plan length PL of line pq and the inclination θ of line $p'q'$ to xy . Print the values as answer, below the drawing.

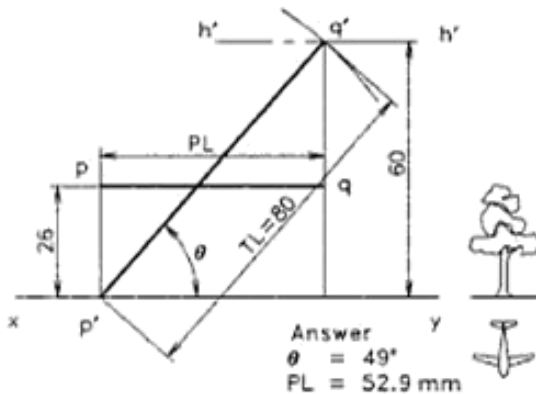

Fig. 10.9 Line inclined to HP (line in 2nd quadrant).

Example 10.8

Line RS of length 84 mm is placed in the fourth quadrant so that it is parallel to HP and the ends are 60 mm below. If the end R is 40 mm and end S is 15 mm in front of VP, draw the projections and find the elevation length and inclination of the line with VP.

Refer to Fig. 10.10

1. Draw the xy -line. Locate the top view of the end r at a distance of 40 mm and s at a distance of 15 mm in front of VP (xy line). The point s is obtained after drawing the vv line at 15 mm distance and cutting an arc of radius 84 mm from r on it.
2. Draw vertical projectors through points r and s .
3. Draw a horizontal line $r's'$, 60 mm below the xy line (HP) to represent the elevation.
4. Finish the drawing and print the given dimensions as shown in the figure.

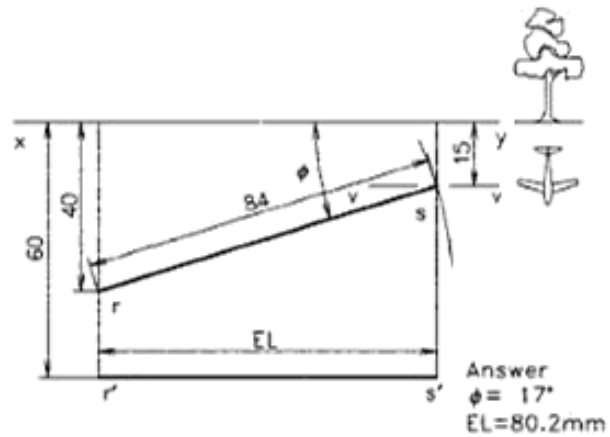

Fig. 10.10 Line inclined to VP (line in 4th quadrant).

5. Measure the elevation length EL and the inclination ϕ with VP (the xy line) and print the values.

10.6 TRACE OF AN INCLINED LINE PLACED IN ONE QUADRANT

The point at which a line or the produced line meets the reference plane is called the *trace* of the line on that plane. If a line is perpendicular or inclined to a plane, the line will penetrate that plane to form a trace when it is produced. But if the line is parallel to a plane, it will not meet that plane and hence there will be no trace on that plane. Figure 10.11(a) shows the pictorial view of a line inclined to HP but parallel to VP. Here, the produced line meets the HP to form a trace called *Horizontal Trace (HT)*. The front view of the point HT will be on the xy line and is marked as h' . Similarly Fig. 10.12(a) shows the pictorial view of a line inclined to VP but parallel to HP. Here, the meeting point of the produced line on VP is called the *Vertical Trace (VT)*. The top view of the trace VT will be also on the xy line and is marked as v . The orthographic projections of these lines are shown in Figs. 10.11(b) and 10.12(b).

Example 10.9

A line AB of length 60 mm is parallel to VP and 30 mm in front of it. If the point A is 16 mm above and the point B is 50 mm above HP. Draw its projections and find the horizontal trace.

Refer to Fig. 10.11.

1. Draw the front view as $a'b'$ and top view as ab of the given line AB as shown in the Fig. 10.11.
2. Extend $b'a'$ to meet the xy line at h' .
3. Draw a projector through h' to intersect the line ba , extended at the point HT.
4. Finish the drawing with proper line thickness and print the given dimensions.

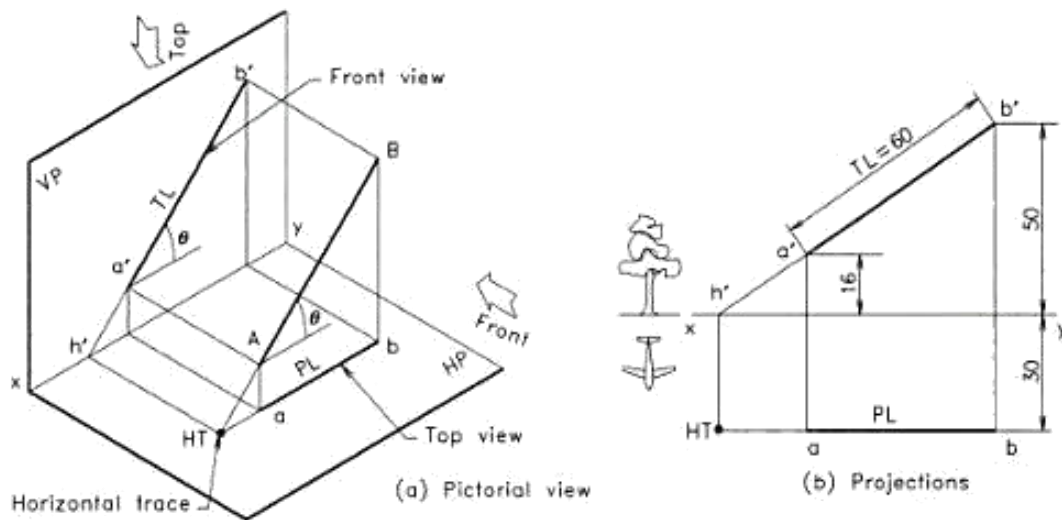

Fig. 10.11 Horizontal trace of an inclined line (line in 1st quadrant).

Properties of traces

1. Trace of a line on a plane exists, if the line is inclined or perpendicular to that plane.
2. The HT of a line will be on the top view, or the top view produced. Similarly VT of a line will be on the front view or front view produced.
3. The point h' will be on the xy line as well as on the front view or front view produced. Similarly, the point v will be on the xy line as well as on the top view or top view produced.
4. The line joining HT and h' is a projector, hence it will be perpendicular to xy line. Similarly the line joining VT and v is a projector, perpendicular to the xy line.

Example 10.10

The end C of a line CD is 20 mm in front of VP while the end D is 32 mm above HP. The line is parallel to HP and 45° inclined to VP. Draw its projections and mark its vertical trace, if the length of the line is 50 mm.

Refer to Fig. 10.12.

1. Draw the top view cd and then the front view $c'd'$ of the line CD as shown in figure.
2. Extend dc to meet the xy line at v .
3. Draw a projector through v to intersect the line $d'e'$ extended at the point VT.
4. Finish the drawing with proper line thickness and print the given dimensions.

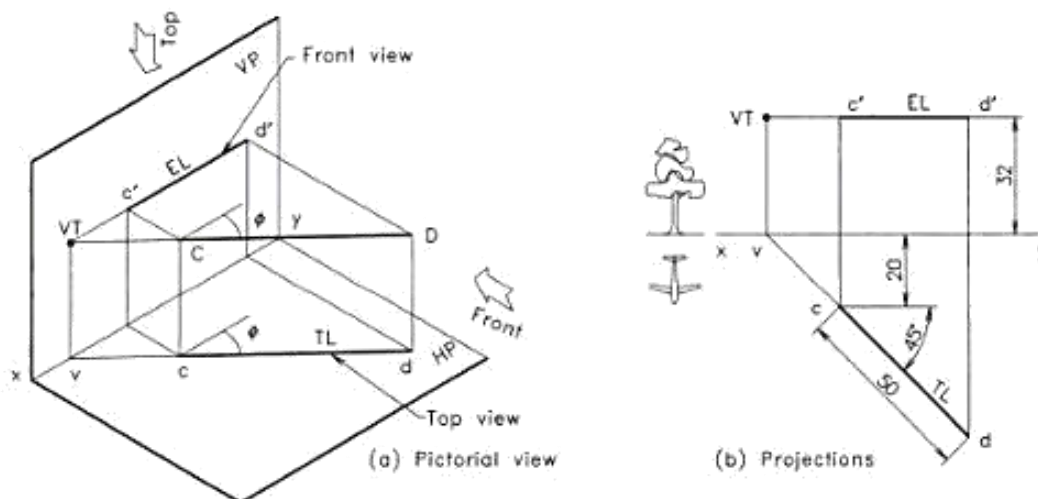

Fig. 10.12 Vertical trace of an inclined line (line in 1st quadrant).

10.7 TRACE OF AN INCLINED LINE PLACED IN TWO QUADRANTS

When an inclined line is placed in two quadrants it will be penetrating one of the reference planes. The point of penetration will be its trace. Since the line is parallel to one of the planes, it will be having only one trace and that is the penetration point. Figure 10.13 shows the vertical trace of an inclined line placed in 1st and 2nd quadrants. Similarly, Fig. 10.14 shows the horizontal trace of an inclined line placed in 2nd and 3rd quadrants.

Example 10.11

A line PQ, 70 mm long is parallel to HP. Its one end P is 20 mm in front of VP and Q is 30 mm behind VP. If the line is 40 mm above HP, draw the projections, locate the traces and find its inclination to VP.

Refer to Fig. 10.13.

1. Draw the xy -line. Locate the top view of the point p at a distance of 20 mm in front of the VP (xy line).
2. Draw a line vv of any length to represent the path of the top view of the point Q, parallel to and at a distance of 30 mm behind the xy line. Now, the top view of the point Q lies on vv and the length of the top view i.e. $pq = 70$ mm. With centre P and radius = 70 mm, draw an arc to cut the line vv at q .
3. Draw projectors through points p and q . Also draw a horizontal line $p'q'$ at a height of 40 mm above the VP (xy line), to get the elevation.
4. The inclination of the top view with the xy line is the inclination of the line PQ with VP.
5. Locate v at the intersecting point of plan pq on xy and draw a projector at v to meet the elevation $p'q'$ at VT.
6. Finish the drawing, measure angle ϕ and print the given dimensions as well as the answer.

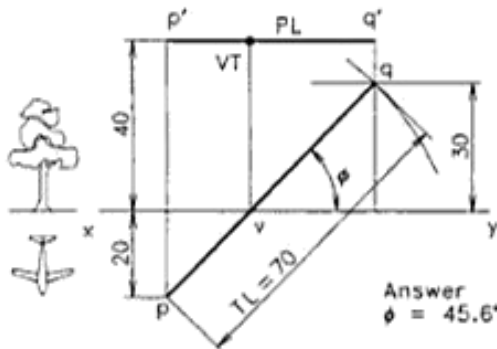

Fig. 10.13 Trace of a line inclined to VP (line in two quadrants).

Example 10.12

The front view of a line RS is 80 mm long and it makes an angle of 45° to xy line. The midpoint m' of the line $r's'$ is 8 mm below the xy line and the end R is in the second quadrant. If the line is 16 mm behind and parallel to VP, draw its projections and mark the traces.

Refer to Fig. 10.14.

1. Draw the xy line.
2. In the given position, the end R is in the 2nd quadrant and the end S is in the 3rd quadrant. Locate the mid point as m' and m , 8 mm below and 16 mm behind the xy line.
3. Draw the front view $r's'$ 80 mm long, inclined at 45° to xy line, through the midpoint m' so that $m's'$ is 40 mm and the end R is situated above HP (xy line).
4. Draw the end projectors through r' and s' and construct the line rs , 16 mm behind and parallel to VP (xy line) to get the top view of RS.
5. Draw projector $m'm$, measure the top view length PL and print the value as the answer.
6. To locate the HT, mark h' at the crossing point of $r's'$ on the xy line and draw projector through h' to intersect the top view at HT.
7. Finish the drawing with proper line thickness and print the given dimensions.

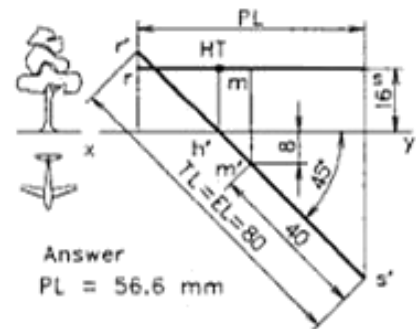

Fig. 10.14 Trace of a line inclined to HP (line in two quadrants).

10.8 THREE VIEWS AND TRACES OF AN INCLINED LINE

The left side view on the profile plane PP is considered as the third principal view added to the usual front and top views. The method of getting profile plane view of a point is already explained in Chapter 9 (Refer Figs. 9.21 and 9.22.) The same procedure is followed for straight lines also. Figure 10.15 shows three views of an inclined line parallel to VP, placed in the first quadrant.

For easy understanding of the projections of planes, the left side portion of the projection may be considered on the space for usual front and top views and the right side portion for the end view of HP and VP, forming the four quadrants. These two portions may have any distance, since the distance of the line from PP is not usually specified. Here, the points on profile view are identified by adding double prime to lowercase letters as shown. The view of HT on profile plane is h'' and is obtained on end view of HP (xoy), where the profile view $a''b''$ or its extension intersects.

A line inclined to VP and parallel to HP is shown in Fig. 10.16. The line is in the third quadrant. Here the side view is a horizontal line $d''c''$. The view of VT on profile plane is v'' and is obtained on end view of VP (zoy_1), where the profile view $c''d''$ or its extension intersects.

Example 10.13

Line AB is parallel to VP and has a plan length 48 mm in the top view. If the end A is 40 mm above HP, and 24 mm in front of VP while the end B is 10 mm above HP, draw the front, top and side views of the line. Also mark its traces on the three views. What is the true length and inclination of the line?

Refer to Fig. 10.15.

1. Draw the xoy line horizontal and the zoy_1 line vertical through the origin o as shown.
2. Mark front and top views a' and a of the end A, after drawing vertical projector at any convenient distance from zoy_1 line.
3. Draw ab , the top view of length 48 mm parallel to xy and locate b' 10 mm above HP, after drawing a vertical projector through b . Join $a'b'$ to get the front view.

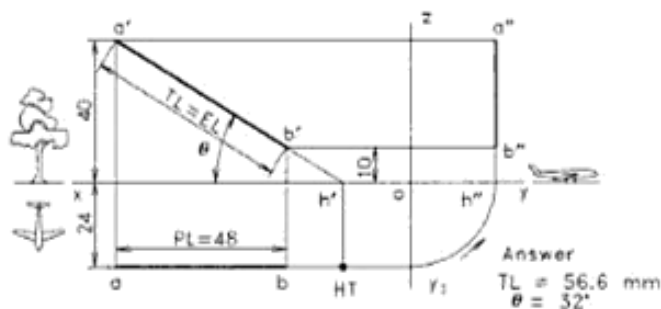

Fig. 10.15 Three orthographic views of a line in the 1st quadrant.

4. Draw horizontal projector through points a and b to meet oy_1 line, rotate it anticlockwise about the origin o to meet xoy (direction opposite to rabation) and then project upwards. Insert horizontal projectors through a' and b' to intersect this line at points a'' and b'' , which gives the side view.
5. Extend $a'b'$ to intersect xy line at h' and mark HT by drawing vertical projector. The side view of HT is marked as h'' and is obtained on the end view of HP (xoy line), where the profile view $a''b''$ or its extension intersects.
6. Measure $a'b'$ as true length and its inclination to HP as θ . Print the given dimensions and the answer.

Example 10.14

A line CD is parallel to HP and has a length 60 mm. If the end C is 20 mm below HP, and 10 mm behind VP while the end D is 36 mm behind VP, draw the front, top and side views of the line. Mark its traces in the three views. Also find the elevation length and inclination of the line to VP by graphical methods.

Refer to Fig. 10.16.

1. Draw the xoy line horizontal and the zoy_1 line vertical through the origin o as shown.
2. Mark front and top views of the line CD as $c'd'$ and cd as shown in the figure. Note that the line is in the 3rd quadrant.
3. Draw horizontal projectors from c and d to meet line oz (side view of VP) and rotate them anticlockwise about the origin o (direction opposite to rabation) to the line oxy (side view of HP). Project downwards from there to meet the horizontal projector drawn from $c'd'$, to get the required side view $c''d''$.
4. Extend cd to intersect the xy line at v and project downwards to meet the line $c'd'$ produced at VT.
5. The side view v'' of VT is on the line oy_1 (side view of VP) and is obtained by extending $d''c''$.
6. Measure $c'd'$ as elevation length and the inclination to VP as ϕ . Print the given dimensions and the answer.

10.9 LINE INCLINED TO BOTH THE HP AND VP (OBLIQUE LINE)

View of a Line In Oblique Position

Figure 10.17 gives the pictorial view of an inclined line moving to oblique position (inclined to both the HP and VP). Here, line AB_1 is parallel to VP and inclined θ° to HP. The top

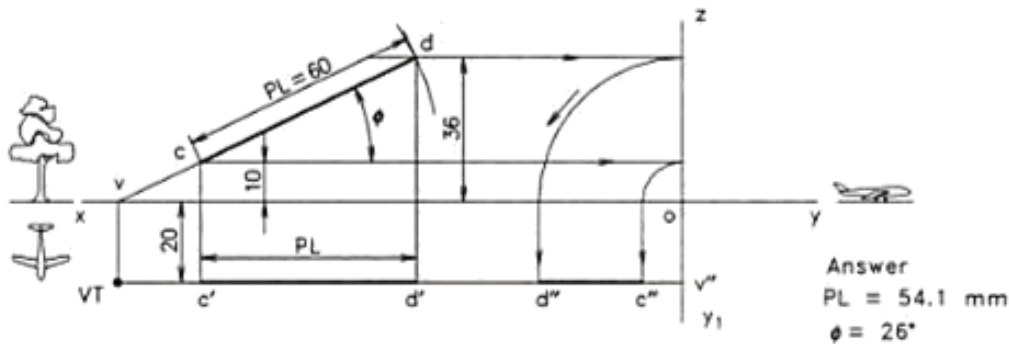

Fig. 10.16 Trace of a line inclined to VP (line in two quadrants).

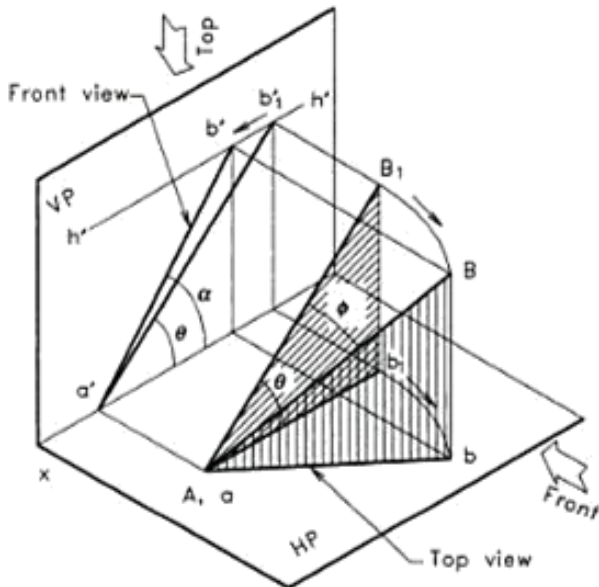

Fig. 10.17 Line inclined to both the planes.

view ab_1 , the projector B_1b_1 and the line AB_1 forms a right-angled triangle like a set-square. As the set-square containing the line AB_1 moves from its parallel position (parallel to VP) to the inclined position AB , the line becomes ϕ° inclined to VP also. This is the oblique position of the line (inclined to HP and VP). As the line moves to oblique position, the projector moves from b_1' to b' . Note that this will increase the true angle θ° to the apparent angle α° in the front view.

When the line AB_1 moves to the AB position, the top view ab_1 also moves to ab position, making an angle of β with xy line. Here, β is the inclination of top view to the xy line, which is the apparent angle corresponding to the true angle ϕ . Angle β will be larger than the true angle ϕ . Note that the true angle (θ or ϕ) of an oblique line is measured along a plane, which is containing the line and kept perpendicular to the reference plane.

The following points may be remembered while solving a problems of oblique lines.

Properties of oblique line

1. If a line is inclined to both the planes (oblique line), its projections will have shorter lengths (EL and PL) than the true length (TL).
2. The projections of oblique line will make apparent angles α and β to the xy line and these angles will be larger than their true angles θ and ϕ .

The Conical Movement of Line from Parallel to Oblique Position

The method of solving problems of oblique lines can be illustrated by the pictorial views given in Figs. 10.18 and 10.19. A line position, which is inclined to both the planes, may be represented by a generator (straight line on the conical surface) of a semi-cone with vertical axis. Refer to Fig. 10.18(a). The generator AB of the semi-cone is parallel to VP and inclined at θ° (true angle) to HP in the initial position. As the end B_1 is moving along the base of the cone, keeping the angle θ constant and end A fixed, the top view of B_1 moves along arc b_1b and the front view moves along the horizontal line (locus line $h'h'$) from b_1' to b' . Let B be any intermediate point along the path. In this position, the front view $a'b'$ makes an angle α° with xy line, which is larger than θ° . The length of the front view (EL) is less than the true length $a'b_1'$ (TL). The required oblique position of the line will be anywhere between the starting point B_1 and the mid position B_3 . In the top view, the point b_1 moves along the arc b_1b with centre a and radius PL . Orthographic view of this line position is given in Fig. 10.18(b).

Consider a second semi-cone having a horizontal axis as given in Fig. 10.19(a), so that the oblique line is a generator of that cone also. Assume that the straight line is initially parallel to HP and is ϕ° inclined to VP (line AB_2). Now its top

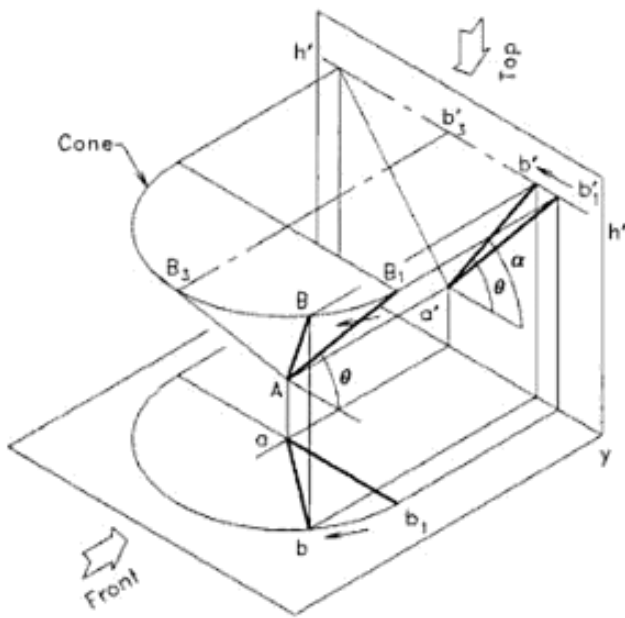

(a) Pictorial view

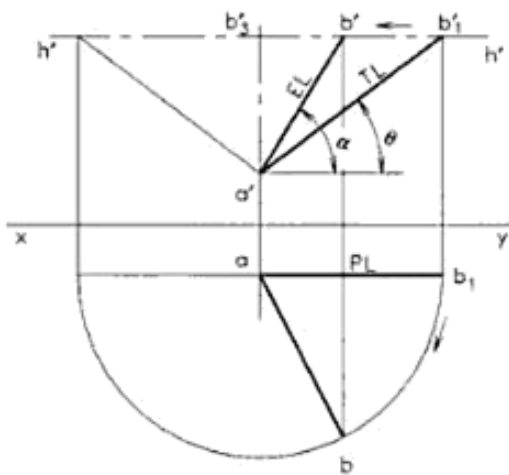

(b) Projections

Fig. 10.18 Line moving from position parallel to VP to the inclined position.

view ab_2 will show the true length and inclination. But, if the line is revolving about the fixed point A, keeping the inclination ϕ° to VP a constant, it will form the horizontal cone as shown in the figure. As the end B_2 moves along the base of the semi-cone, the top view of it moves along the locus line vv from b_2 to b , which is parallel to xy line. The point b_2' of the front view moves along an arc with centre a' and radius EL . In this position, the top view ab makes an

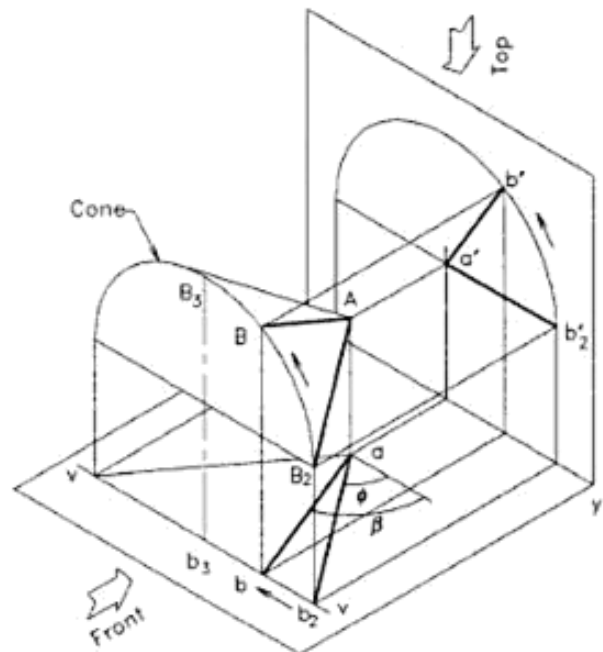

(a) Pictorial view

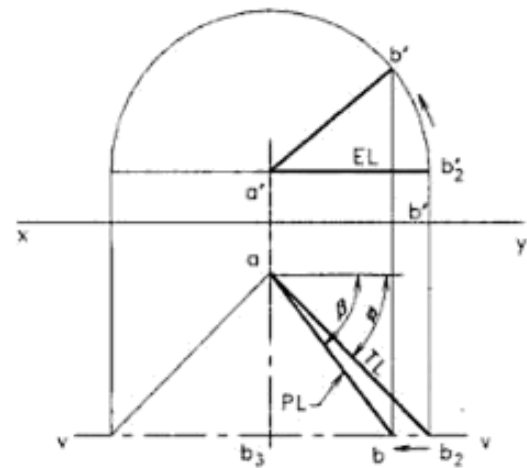

(b) Projections

Fig. 10.19 Line moving from position parallel to HP to the inclined position.

apparent angle β° , which is larger than ϕ° and the length of ab (PL) is less than the true length AB. Orthographic views of this line position is given in Fig. 10.19(b).

Principle of Getting the Projections

Now, if the required true inclinations of the line to HP and VP are θ° and ϕ° , that position can be obtained by combining the

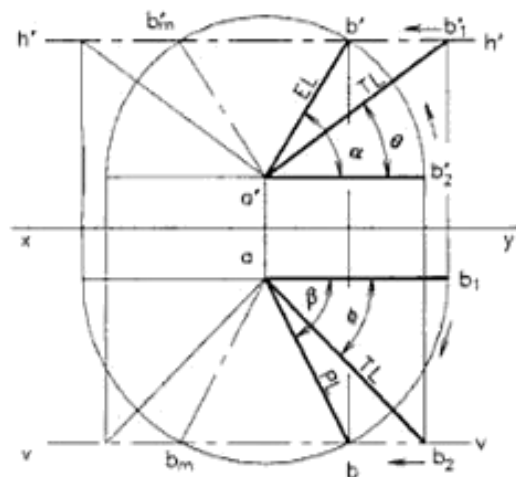

TL = True length of line
EL = Elevation length of line
PL = Plan length of line

(a) The combined form of views

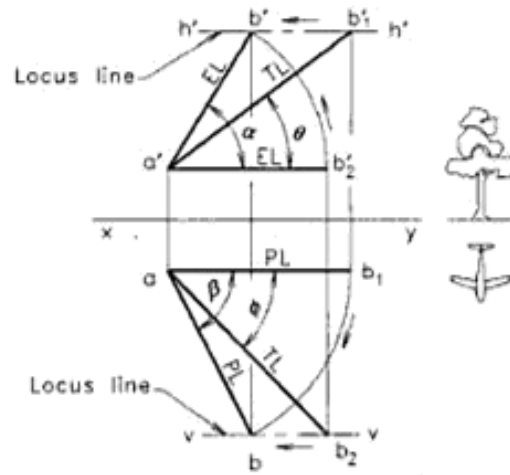

θ = True inclination to HP
 α = Apparent inclination of front view
 ϕ = True inclination to VP
 β = Apparent inclination of top view

(b) The final form of views

Fig. 10.20 A Line inclined to both the reference planes.

Figs. 10.18(b) and 10.19(b) as given in 10.20(a). It may be concluded that the required position of the point satisfying the two inclinations is the intersection of the circular path of b'_2 and linear path of b'_1 at b' in the front view. The line joining a' and b' is the required front view of the line AB. Similarly, in the top view, the intersection of the circular path of b_1 and linear path of b_2 at b gives the position of the end point, satisfying the two inclinations. The line joining a and b is the required top view of the line AB. The apparent angles α and β , are larger than θ and ϕ respectively. The projector joining b and b' will be perpendicular to xy line. This property can be used as a check for the accuracy of the drawing.

In the Fig. 10.20(a), there is the possibility of obtaining a second position of point B as a mirror image (b'_m and b_m), satisfying the given conditions. If the mirror image is eliminated the final form is as given in Fig. 10.20(b). Here, $h'h'$ is the locus of B in the front view and vv is the locus of B in the top view.

Properties of Projections of an Oblique Line

1. The elevation length EL and the plan length PL of an oblique line are always less than the true length TL.
2. The apparent angle α of the front view with xy line is always larger than θ , the true inclination with HP. Similarly, the apparent angle β of the top view with

xy line is always larger than ϕ , the true inclination with VP.

3. The locus line $h'h'$ is the path of end of an oblique line in front view, while it moves from parallel to oblique position. Similarly, the locus line vv is the path of end of the oblique line in top view, while it moves from parallel to oblique position.
4. The locus lines $h'h'$ and vv are always parallel to the xy line and they may be positioned on both sides or on one side of the xy line, depending on the position of the oblique line.
5. Since a visible object is to be presented using thick line in projections as per BIS, all the views of the given line are to be converted into thick (Type A) line while finishing the drawing.

Example 10.15

A line AB, 60 mm long has its end A in the HP and 20 mm in front of VP. If the line is 45° inclined to HP and 30° inclined to VP, draw its projections.

Refer to Fig. 10.21.

1. Draw the xy line.
2. Locate point a' on xy line and point a 20 mm in front of xy line.
3. Draw line $a'b'_1 = 60$ mm (TL) long, at the angle 45° to xy line and project to get the plan view ab_1 (PL).
4. Draw a line $ab_2 = 60$ mm (TL) long, at the angle 30° to xy line and project to get the front view $a'b'_2$ (EL).

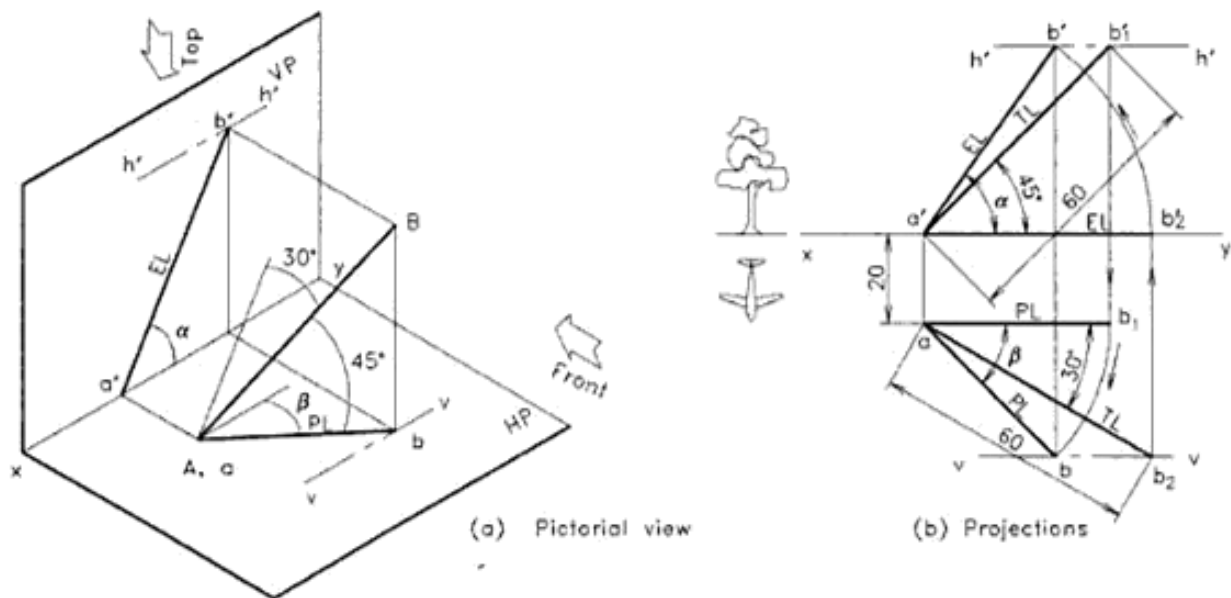

Fig. 10.21 Oblique line in first quadrant.

5. Draw line $h'h'$, the locus of b'_1 and a line vv , the locus of b_2 , parallel to xy line.
6. Draw the locus of b'_2 by drawing an arc with centre a' and radius = $a'b'_2$ (EL.) to intersect the line $h'h'$ at b' . Join $a'b'$ to get the required front view.
7. Draw the locus of b_1 by drawing the arc with centre a and radius = ab_1 (PL), to intersect the line vv at b . Join ab to get the required top view.
8. Drop a perpendicular from point b' to xy line and extend it so that the projector will pass through point b .
9. Give proper line thickness and print the given dimensions as shown in Fig. 10.21(b) to complete the drawing.

4. With centre p and radius pq_2 (PL), draw arc to intersect the locus line vv at q . Join pq to get the top view.
5. Draw a projector through q to intersect the locus line $h'h'_1$ at q'_3 . Join q'_3 to p'_1 to get the front view.
6. Since p'_1 is an assumed position of the point and q'_3 is to be at 50 mm above HP, lift the front view ($q'_3p'_1$) to the position q' , without changing the angle α . This gives the required front view $p'q'$.
7. The same can be directly obtained by drawing an arc with centre q' and radius = the elevation length EL to cut the projector drawn through p at p' . Join $p'q'$ to get the required front view.
8. Give proper line thickness and print the given dimensions to complete the drawing as given in Fig. 10.22(b).

Example 10.16

A line PQ, 64 mm long has one of its extremities 20 mm in front of VP and the other 50 mm above HP. The line is inclined at 40° to HP and 25° to VP. Draw its top and front views.

Refer to Fig. 10.22.

1. Draw the xy line and locate the end P at 20 mm in front of VP and assume it on HP as p and p'_1 . Draw the locus line $h'h'_1$ of end Q, 50 mm above HP.
2. Draw the line $pq_1 = 64$ mm (TL) at an angle 25° to VP and project to get the elevation length $p'_1q'_1$ (EL).
3. Draw another line $p'_1q'_2 = 64$ mm at an angle 40° to VP and project to get the plan length pq_2 (PL).

Example 10.17

One end M of the line MN, 80 mm long is 10 mm below HP and 15 mm behind VP. The line is inclined at 40° to HP and the top view makes 50° with VP. Draw projections, if the line is in the third quadrant.

Refer to Fig. 10.23.

1. Draw the xy line and locate the end M at 15 mm behind VP and 10 mm below HP.
2. Keep the line parallel to VP and inclined 40° to HP and then draw the locus line $h'h'_1$ of the end n'_1 .
3. Project from the parallel line end and find the plan length (PL) mn_1 . Draw the plan view mn of length equal to PL and inclined 50° to xy line.

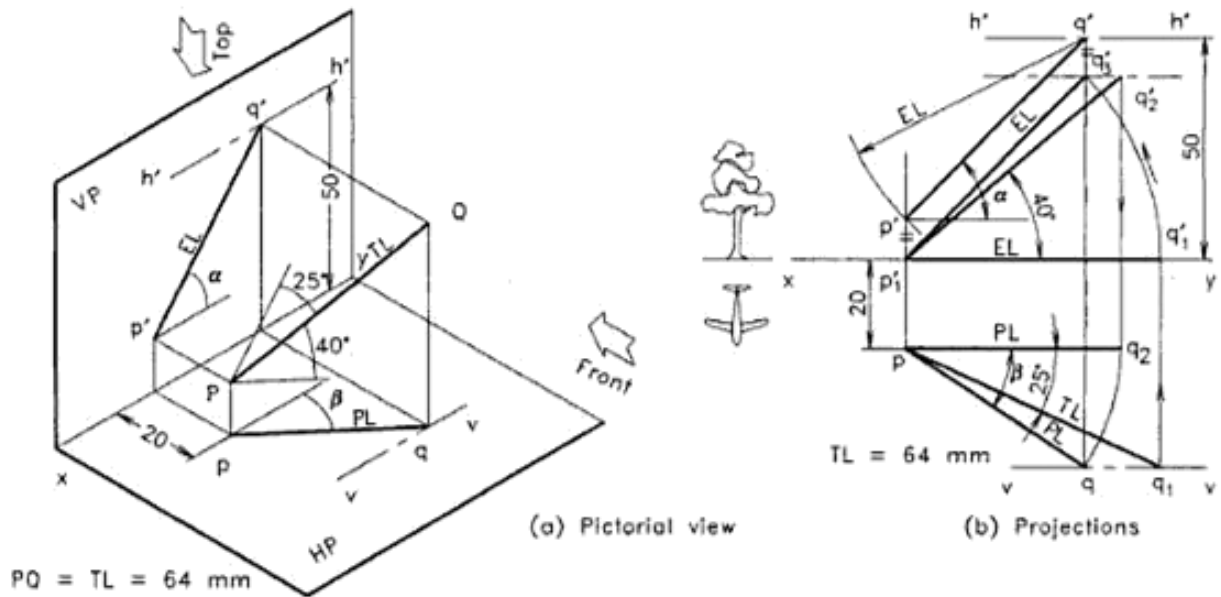

Fig. 10.22 Oblique line in first quadrant.

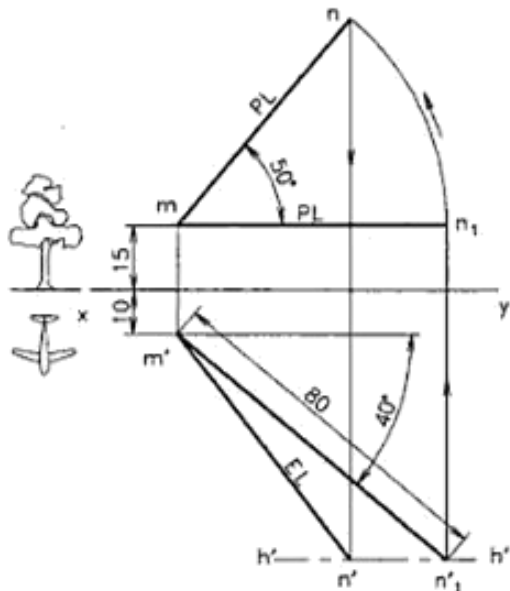

Fig. 10.23 Oblique line in the third quadrant.

4. Project vertically from n to intersect $h'h'$ line at n' so that, by drawing line $m'n'$ the front view is obtained.
5. Give proper line thickness and print the given dimensions to complete the drawing.

Example 10.18

Line CD is in the second quadrant and has 25° inclination with HP, while the front view has 30° inclination with xy line

and 60 mm length. If the end C is 12 mm above HP and the end D is 60 mm behind VP, draw its projections.

Refer to Fig. 10.24.

1. Draw the xy line and locate the end C, 12 mm above HP and draw the front view $c'd'$ of length 60 mm and inclination 30° to xy line.
2. Mark the locus line $h'h'$ through d' and draw the true length line $c'd_1$ at 25° with HP. Project vertically from d_1 to get the plan c_1d_1 on xy line.
3. Draw the vv line at 60 mm behind VP and drop a projector through d' to locate d . Cut an arc of radius equal to PL from d to get point c on the projector through c' , so that cd is the required top view.
4. Give proper line thickness and print the given dimensions to complete the drawing.

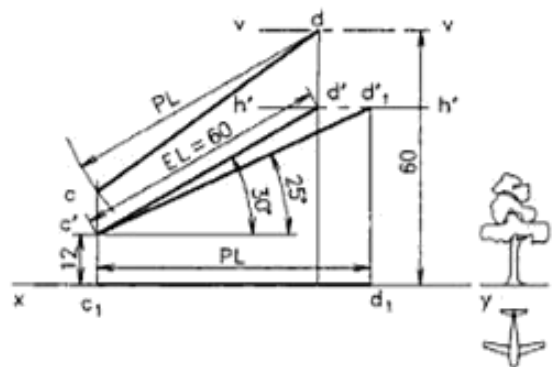

Fig. 10.24 Oblique line in the second quadrant.

Urheberrechtlich geschütztes Material

Example 10.19

A 100 mm long line EF has 70 mm length in the top view and 84 mm length in the front view. If the line end E is in HP and F is in VP, draw its projections, keeping the line in the fourth quadrant.

Refer to Figs. 10.25.

1. Draw the xy line and locate the end E on HP as well as on VP by e' and e_1 .

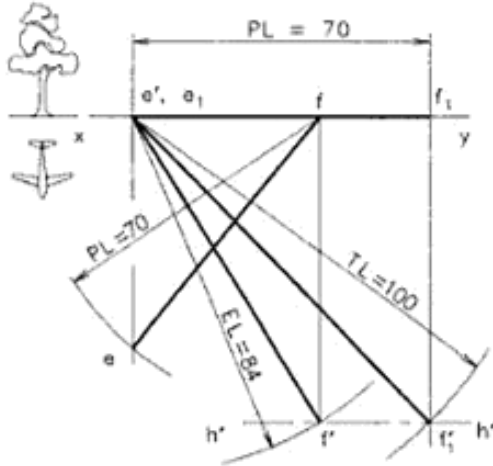

Fig. 10.25 Oblique line in the fourth quadrant.

2. Mark e_1f_1 as the plan length 70 mm on xy line and drop a vertical projector through f_1 . Cut an arc with centre e' and radius equal to the true length 100 mm to cut the projector drawn at f'_1 .

3. Draw the locus line $h'h'$ through f'_1 and cut the elevation length 84 mm on that line to get f' . Join $e'f'$ as the front view.
4. Since end F is in VP, the top view f will be on xy line and is located on the vertical projector drawn from f' .
5. To get the top view of the line cut an arc with centre f and radius equal to plan length 70 mm on the projector drawn through e' . The line ef gives the required top view.
6. Give proper line thickness and print the given dimensions to complete the drawing.

10.10 TRACES OF AN OBLIQUE LINE

If a line is inclined to both HP and VP (oblique), the line or the line produced will penetrate the two planes forming both the horizontal trace (HT) and the vertical trace (VT) [see Fig. 10.26(a)]. The properties of the traces are the same as that explained for inclined lines, but are combined together or superimposed. From the projections [Fig. 10. 26(b)], the following features may be noted:

1. The points p' , q' , h' and VT lie on a straight line inclined α° and h' is located on the xy line.
2. The points p , q , v and HT lie on a straight line inclined β° and v is located on the xy line.
3. The horizontal trace HT and its front view h' lie on a vertical projector.
4. The vertical trace VT and its top view v lie on another vertical projector.

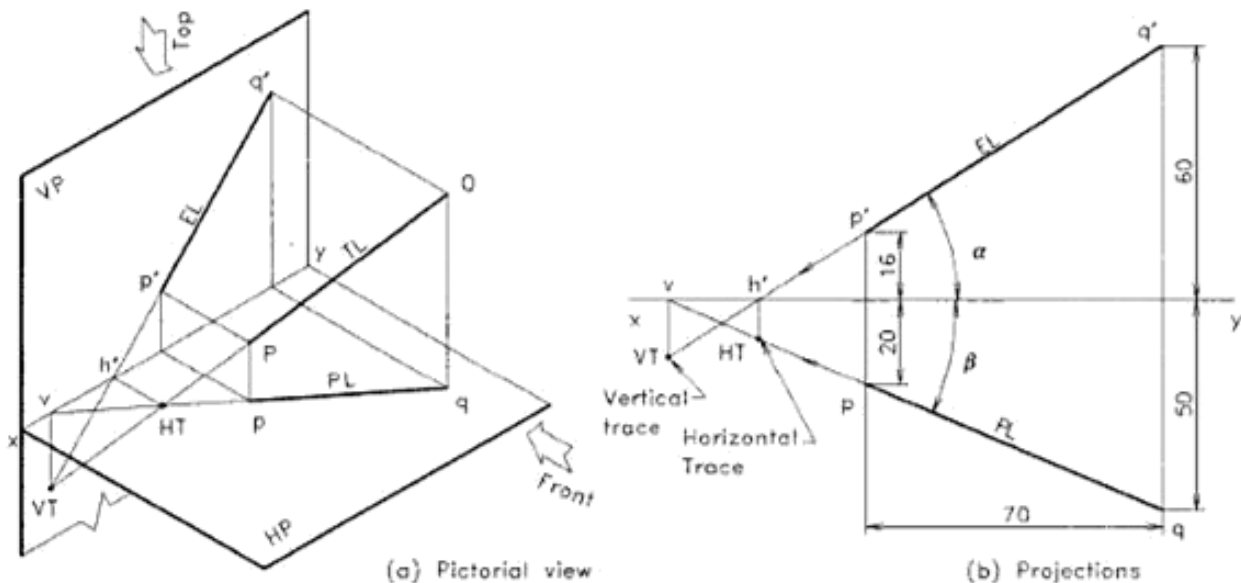

Fig. 10.26 Traces of an oblique line placed in 1st quadrant.

In order to locate the HT of a line, extend the front view to cross xy line at h' and drop a vertical line through the point to intersect on the top view or top view produced. This intersection point gives HT. Similarly, to locate VT of a line, extend the top view to cross xy line at v and drop a vertical line through the point to intersect on the front view or front view produced. This intersection point gives VT. Note that h' and v are located always on the xy line.

Example 10.20

An end P of a line PQ is 16 mm above HP and 20 mm in front of VP while the end Q is 60 mm above HP and 50 mm in front of VP. If the end projectors are at a distance of 70 mm, draw the top and front views of the line and mark its traces.

Refer to Fig. 10.26.

1. Draw the xy line and locate the points p, p', q and q' at the given dimensions and draw the top view and front view of the line PQ as shown in figure.
2. Extend $q'p'$ to cross xy line at h' . Similarly, extend qp to cross xy line at v .
3. Drop vertical lines through h' and v to intersect the lines qp and $q'p'$ produced to intersect at HT and VT respectively.
4. Give proper line thickness and print the dimensions to complete the drawing.

Example 10.21

The projections of a line AB has 35° inclination in top view and 40° inclination in the front view with an elevation length of 60 mm. If the end A is 10 mm below HP and B is 12 mm behind VP, draw the projections and locate the traces keeping the line in the third quadrant.

Refer to Fig. 10.27.

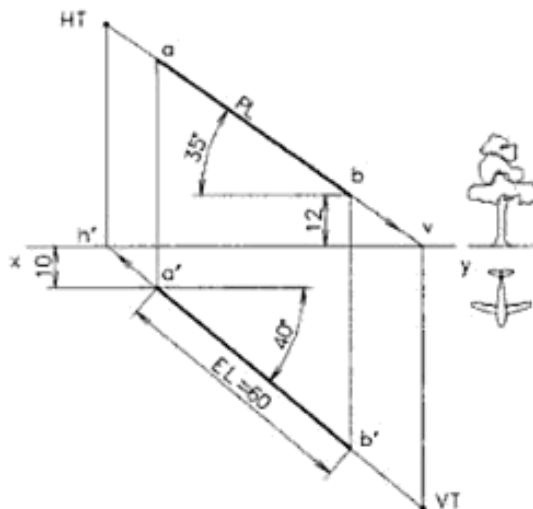

Fig. 10.27 Traces of an oblique line placed in 3rd quadrant.

1. Draw the xy line and locate the points a' 10 mm below HP.
2. Draw the elevation $a'b'$ of 60 mm length and of inclination 40° to xy line.
3. Locate the end b , 12 mm behind VP on the projector through b' and draw the plan ab at 35° inclination.
4. Extend the elevation $a'b'$ to get h' on xy line and draw projector through h' to intersect the plan extended at HT.
5. Extend the plan ab to get v on xy line and draw projector through v to intersect the elevation extended at VT.
6. Give proper line thickness and print the dimensions to complete the drawing.

10.11 TRUE LENGTH AND TRUE INCLINATIONS OF AN OBLIQUE LINE

The true length and true inclination of a line is seen in a projection when the line is parallel to that plane of projection. This principle is followed to determine the true length and inclination of a line inclined to both the reference planes. Two methods are suggested here for finding them.

Parallel Line Method

In this method, each view of the line is made parallel to the xy line (i.e. elevation EL and plan PL are rotated so that they are parallel to the reference planes) and is projected to get the parallel view from it. This is a reversal of the process explained for drawing the projections of an oblique line. When the line is parallel to a plane, it will show its true length TL and true inclination θ° or ϕ° on that plane. This method of finding the true length and inclinations is explained in Example 10.22(a).

Plane Rotation Method

In this method, the triangular plane containing the projected view of the line, the trace on it, and the original line is rotated about the projected view to coincide with the plane of projection. This can be made clear by the pictorial view, as shown in Figure 10.28. Here, the triangular plane containing plan ab , the trace HT, and the original line AB is rotated about the plan ab to fall on HP. This triangle gives the true angle θ° at HT and the true length AB. Similarly, the triangular plane containing $a'b'$, VT and AB can be rotated about $a'b'$ to fall on the VP to get the true angle ϕ° and the true length AB. This method of finding the true length and inclinations is explained in Example 10.22(b).

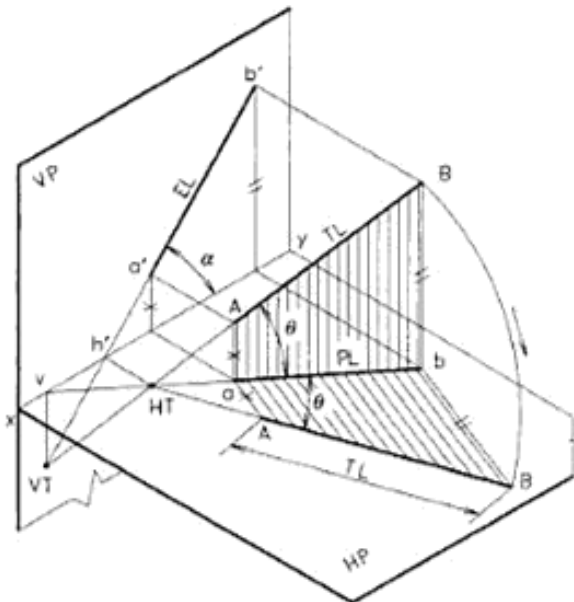

Fig. 10.28 True length and inclinations (Plane rotation method).

Example 10.22

An end A of a line AB is 16 mm above HP and 20 mm in front of VP, while the end B is 60 mm above HP and 50 mm in front of VP. If the end projectors are at a distance of 70 mm, find the true length and true inclination of the line to the reference planes by the following methods:

- Parallel line method.
- Plane rotation method.

(a) Parallel line method

Refer to Fig. 10.29(a).

- Draw the xy line and mark the end points a' , b' , a and b as per given dimensions and complete the front and top views.
- Draw the locus lines $h'h'$ and vv through b' and b respectively.
- Rotate ab about a to bring it parallel to xy and project vertically to meet $h'h'$ at b'_1 . Join a' and b'_1 to get the true length (TL) and true inclination θ' with HP (xy line).
- Similarly rotate $a'b'$ about a' to bring it parallel to xy line and project vertically to meet vv at b_2 . Join ab_2

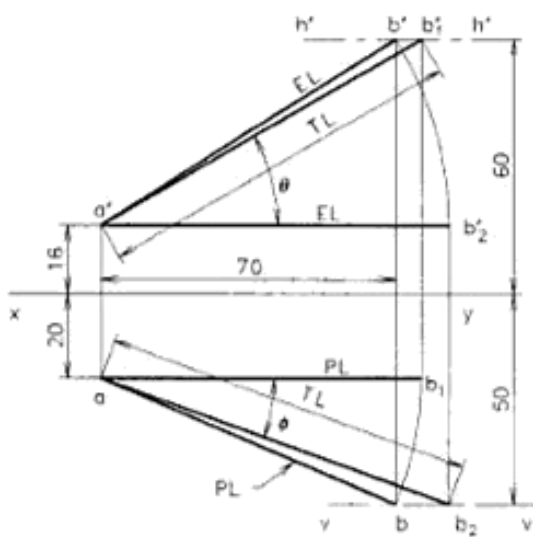

(a) Parallel line method

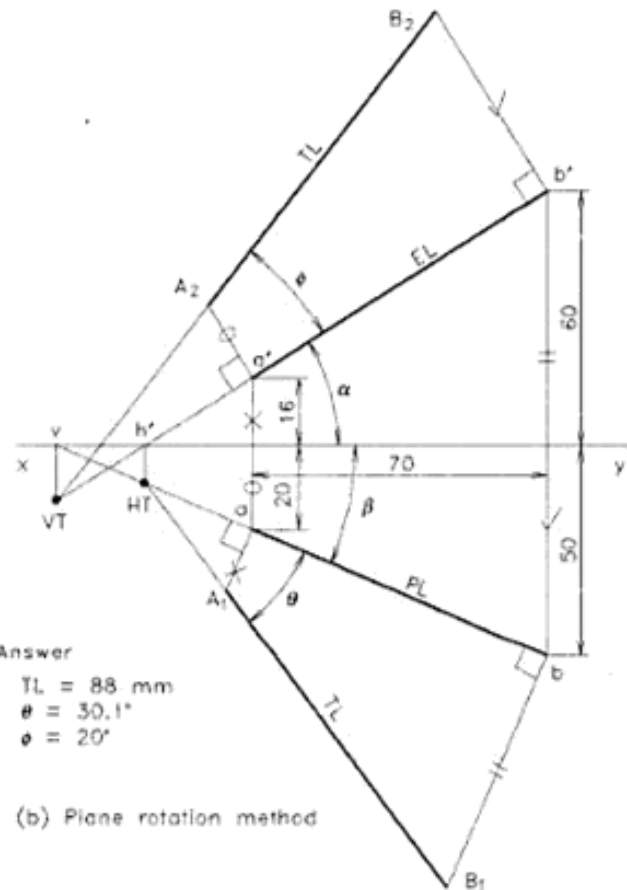

Answer

$$TL = 88 \text{ mm}$$

$$\theta = 30.1^\circ$$

$$\theta' = 20^\circ$$

(b) Plane rotation method

Fig. 10.29 True length and inclinations (oblique line in the first quadrant).

Urheberrechtlich geschütztes Material

to get the true length (TL) of same value and the true inclination ϕ° with VP (xy line).

5. Measure the values and print them below the views as answer.
6. Give proper line thickness and print the dimensions to complete the drawing.

(b) Plane rotation method

Refer to Fig. 10.29(b).

1. Draw xy line and complete the projections of the line as per the given dimensions.
2. Extend the lines $a'b'$ and ab , and mark HT and VT as shown in figure.
3. Draw perpendiculars at b and b' and mark elevation distance of b' from xy line (60 mm) at b and the plan distance of b from xy line (50 mm) at b' , to get points B_1 and B_2 respectively. Join HT to B_1 and VT to B_2 .
4. Also drop perpendiculars at a and a' to get points A_1 and A_2 as shown in the figure. Now $A_1B_1 = A_2B_2 =$ the true length TL of line AB.
5. The angle between plan (PL) and true length line (TL) is $= \theta =$ the true inclination to HP. Similarly, the angle between elevation (EL) and true length line (TL) is $= \phi =$ the true inclination to VP.
6. Measure the values and print them below the view as the answer.
7. Give proper line thickness and print the dimensions to complete the drawing.

Example 10.23

The top view of a line CD has points c and d , 10 mm and 50 mm below the xy line and the front view has points c' and d' , 40 mm and 16 mm above the xy line respectively. Determine:

- (i) the true length and inclinations of the line with HP and VP, and
- (ii) HT and VT of the line.

Take the distance between the end projectors as 66 mm. Refer to Fig. 10.30 (Plane rotation method)

1. Draw xy line and complete the projections of the line as per the given dimensions.
2. Extend the lines $c'd'$ and cd , and mark HT and VT as shown in figure.
3. Draw perpendiculars at c and d' and mark elevation distance of c' from xy line (40 mm) at c and the plan distance of d from xy line (50 mm) at d' , to get points C_1 and D_2 respectively. Join HT to C_1 and VT to D_2 .
4. Also drop perpendiculars at d and c' to get points D_1 and C_2 as shown in the figure. Now $C_1D_1 = C_2D_2 =$ the true length TL of line CD.
5. Angle between plan PL and true length line $TL = \theta =$ the true inclination to HP. Similarly, angle between elevation EL and true length line $TL = \phi =$ the true inclination to VP.
6. Measure the values and print them below the view as answer.
7. Give proper line thickness and print the dimensions to complete the drawing.

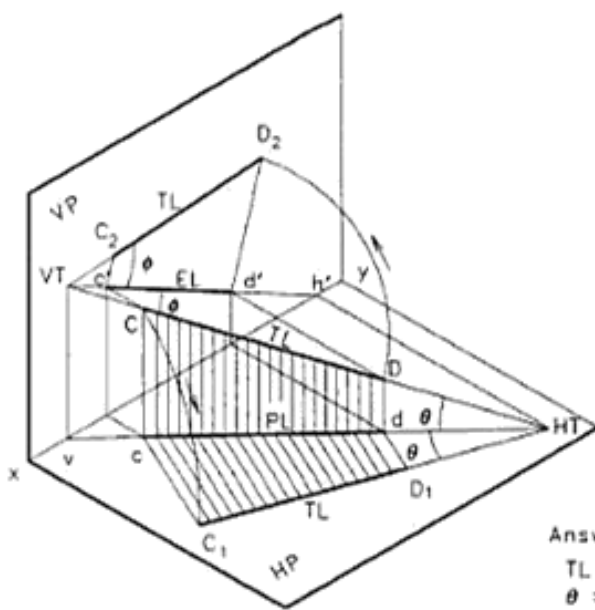

(a) Pictorial view

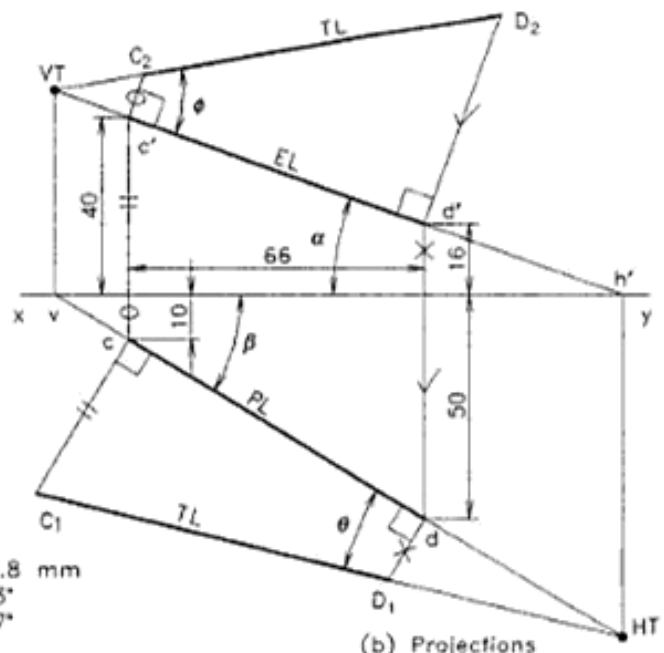

(b) Projections

Answer
 TL = 80.8 mm
 $\theta = 17.3^\circ$
 $\phi = 29.7^\circ$

Fig. 10.30 True length and inclinations (plane rotation method).

EXERCISES

(# Problems similar to the worked out examples)

Line parallel to both or perpendicular to the reference planes

1. A line PQ 70 mm long is parallel to both HP and VP. The point P is 30 mm above HP and the point Q is 50 mm in front of VP. Draw its projections. (#)
2. A 50 mm long line CD is positioned in such a way that it is perpendicular to VP and the end D is 15 mm in front of VP and 40 mm above HP. Draw its projections, keeping the line in the first quadrant. (#)
3. Line EF, 36 mm long is in the first quadrant. The end F is 12 mm above HP and 24 mm in front of VP. If the line is perpendicular to HP draw its projections. (#)
4. Draw projections of a line PQ 70 mm long, when it is placed in the third quadrant and parallel to both HP and VP. The end P is 60 mm below HP, and 50 mm behind VP.
5. Draw projections of a line MN, 60 mm long, placed perpendicular to HP in the third quadrant. The line is 40 mm behind VP and the upper end of the line is 20 mm below HP.

Line Inclined to one of the reference planes

6. A line PQ, 80 mm long is parallel to VP and inclined at 45° to HP. The end P is 10 mm above HP and 35 mm in front of VP. Draw the projections. (#)
7. Line GH is inclined at 30° to VP and is contained in HP. The end G is 20 mm in front of VP. Draw the projections of the line, if the true length of line GH is 70 mm. (#)
8. A line EF, has end E 15 mm below and 45° inclined to HP. If the line is 40 mm behind and parallel to VP, draw projections and find its true length. The distance between the end projectors is 65 mm and the line is in the third quadrant. (#)
9. A line KL, has end K 16 mm behind VP and on HP. If the line has 90 mm length and parallel to VP, draw projections and find its true inclination and plan length. The end L is 56 mm above HP and the line is in the second quadrant. (#)
10. Line AB of length 90 mm is placed in the fourth quadrant so that it is parallel to HP and the ends are 70 mm below. If the end A is 10 mm and end B is 50 mm in front of VP, draw the projections and find the elevation length and inclination of the line with VP. (#)
11. The top view of a line AB measures 60 mm. The line is parallel to VP and inclined at 30° to HP. Its end A is 12 mm below HP and 24 mm behind VP. Draw the projections of the line and determine its true length, assuming that the line is in the third quadrant.
12. A line RS, 80 mm long is parallel to HP. Its end R is 30 mm in front of VP and the end S is 20 mm behind VP. If the line is 36 mm above HP, draw the projections of the line and find the inclination of the line with VP.

Trace of an inclined line

13. A line PQ of length 80 mm is parallel to VP and 35 mm in front of it. If the point P is 60 mm above and the point Q is 15 mm above HP. Draw its projections and find the traces. (#)
14. The end B of a line AB is 10 mm in front of VP while the end A is 40 mm above HP. The line is parallel to HP and 30° inclined to VP. Draw its projections and mark its traces, if the length of the line is 60 mm. (#)
15. A line ST, 80 mm long is parallel to HP. Its one end S is 25 mm in front of VP and T is 40 mm behind VP. If the line is 50 mm above HP, draw the projections, locate the traces and find its inclination to VP. (#)
16. The front view of a line EF is 90 mm long and it makes an angle of 45° to xy line. The midpoint m' of the line $e'f'$ is 10 mm below the xy line and the end F is in the second quadrant. If the line is 15 mm behind and parallel to VP, draw its projections and mark the traces. (#)
17. A 75 mm long line BC has end B in the first quadrant and the other end C is in the second quadrant. If B is 35 mm in front of VP and C is 15 mm behind VP, draw its projections and mark its VT. The line BC is parallel to and 25 mm above HP. Also determine the elevation length of the line.
18. An inclined pipe line is running along a vertical wall of a building, so that one end is touching the floor of the ground floor, while the other end is touching the roof of the first floor. If the distance between the pipe ends measured horizontally is 7 m, while that measured vertically is 8 m. If the roof height of the first floor is 3 m, find graphically the length of the pipe, its inclination to the ground and the point at which the pipe

Urheberrechtlich geschütztes Material

penetrates the first floor. Draw the views to a suitable scale, neglecting the thickness of the slabs.

Three views and trace of an inclined line

19. Line PQ is parallel to VP and has a plan length 50 mm in the top view. If the end P is 12 mm above HP, and 30 mm in front of VP while the end Q is 60 mm above HP, draw the front, top and side views of the line. Also mark its traces on the three views. What is the true length and inclination of the line? (#)
20. A line EF is parallel to HP and has a length 70 mm. If the end E is 25 mm below HP, and 40 mm behind VP while the end F is 12 mm behind VP, draw the front, top and side views of the line. Mark its traces in the three views. Also find the elevation length and inclination of the line to VP by graphical methods. (#)
21. Line CD is parallel to HP and has an elevation length 40 mm. If the end C is 35 mm above HP, and 50 mm in front of VP while the end D is 10 mm in front of VP, draw the front, top and side views of the line. Also mark its trace on the three views. What is the true length and inclination of the line?

Projections of oblique line

22. A line PQ, 80 mm long has its end P in the HP and 30 mm in front of VP. If the line is 30° inclined to HP and 45° inclined to VP, draw its projections. (#)
23. A line AB, 70 mm long has one of its extremities 30 mm in front of VP and the other 70 mm above HP. The line is inclined at 45° to HP and 30° to VP. Draw its top and front views. (#)
24. One end J of the line JK, 90 mm long is 10 mm below HP and 20 mm behind VP. The line is inclined at 35° to HP and the top view makes 45° with VP. Draw projections, if the line is in the third quadrant. (#)
25. Line RS is in the second quadrant and has 30° inclination with HP, while the front view has 40° inclination with *xy* line and 70 mm length. If the end R is 15 mm above HP and the end S is 80 mm behind VP, draw its projections. (#)
26. A 110 mm long line CD has 75 mm length in the top view and 85 mm length in the front view. If the line end

C is in HP and D is in VP, draw its projections, keeping the line in the fourth quadrant. (#)

Traces of oblique line

27. An end A of a line AB is 50 mm above HP and 60 mm in front of VP while the end B is 20 mm above HP and 15 mm in front of VP. If the end projectors are at a distance of 65 mm, draw the top and front views of the line and mark its traces. (#)
28. The projections of a line CD has 45° inclination in top view and 40° inclination in the front view with an elevation length of 70 mm. If the end C is 15 mm below HP and D is 20 mm behind VP, draw the projections and locate the traces keeping the line in the third quadrant. (#)

True length and inclinations of oblique line

29. An end P of a line PQ is 15 mm above HP and 25 mm in front of VP, while the end Q is 60 mm above HP and 50 mm in front of VP. If the end projectors are at a distance of 65 mm, find the true length and true inclination of the line to the reference planes by the following methods:
 - (a) Parallel line method.
 - (b) Plane rotation method. (#)
30. The top view of a line EF has points *e* and *f*, 12 mm and 60 mm below the *xy* line and the front view has points *e'* and *f'*, 50 mm and 15 mm above the *xy* line respectively. Determine: (i) the true length and inclinations of the line with HP and VP, and (ii) HT and VT of the line. Take the distance between the end projectors as 70 mm. (#)
31. Line CD has 80 mm length in the front view and 70 mm length in the top view. The end C is 50 mm below HP and 40 mm behind VP, while the end D is 10 mm below HP. Draw the projections of the line, locate the traces and determine the true length and inclinations of the line with the reference planes. (#)
32. A line MN has end the M on HP and 50 mm in front of VP while the end N is on VP and 40 mm above HP. If the inclination of the top view is 35° to the *xy* line, draw the projections, locate the traces and find the true length as well as the true inclinations of the line with the reference planes.

Projections of Solids

12

A solid may be defined as an object having three dimensions such as length, breadth and thickness, measured along the three mutually perpendicular axes. This chapter discusses the method of drawing of orthographic views of geometrical solids.

For the purpose of drawing, a solid may be considered as a combination of points, lines and planes, flat or curved. The method of projection of points, lines and planes was already discussed in the previous chapters. Here, the procedure and conventions which were discussed in the previous chapters have to be combined and applied together.

12.1 CLASSIFICATION OF SOLIDS

The solids generally used for the study of Engineering Graphics may be classified as:

1. Polyhedra
2. Solids of revolution.

Solids may also be classified as:

1. Right solids, and
2. Oblique solids.

If the axis of a solid is perpendicular to its base or end faces, that solid is called a *right solid*. Further, if all the edges of the base or of the end faces of a right solid are of equal lengths and they form a plane figure, that right solid is called a *right regular solid*. See Fig. 12.1.

If the axis of a solid is inclined to its base or end faces, that solid is called an *oblique solid*. Further, if all the edges of the base or of the end faces of an oblique solid are of equal lengths and they form a plane figure, that oblique solid is called an *oblique regular solid*. Figure 12.2 gives the pictorial views of oblique solids.

A *polyhedron* is defined as a solid bounded by planes called *faces*. Platonic solids, prisms and pyramids are some of the solids coming under this group.

A *solid of revolution* is defined as a solid generated by the revolution of a plane figure about a line called *axis*. Cylinders, cones and spheres are some of the solids coming under this group.

Regular Polyhedra

A regular polyhedron is defined as a solid bounded by regular planes called *faces*, whose edges are equal in length and the angles between the adjacent faces are equal. The following are the five regular polyhedra called *platonic solids*.

1. **Tetrahedron:** It consists of four equal equilateral triangular faces.
2. **Hexahedron (cube):** It consists of six equal square faces.
3. **Octahedron:** It consists of eight equal equilateral triangular faces.

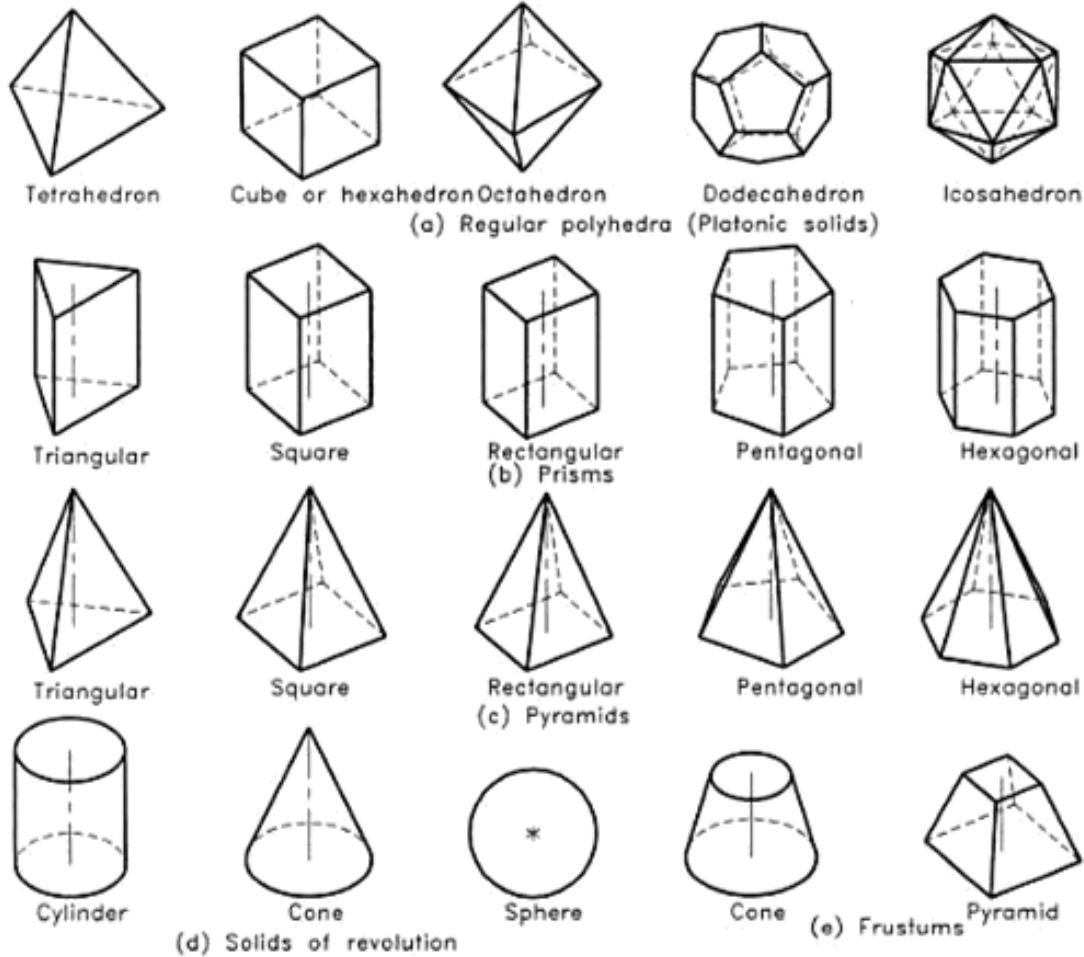

Fig. 12.1 Right regular solids.

4. **Dodecahedron:** It consists of twelve equal pentagonal faces.
5. **Icosahedron:** It consists of twenty equal equilateral triangular faces.

Prisms

A prism is a polyhedron having two equal and similar end faces, parallel to each other and joined by side faces which are either rectangular or parallelograms. Prisms are named according to the shape of the end faces such as triangular, square, rectangular, pentagonal, hexagonal, etc. A parallelepiped is a prism having parallelograms as end faces.

In a right prism, its axis is perpendicular to its base; but in an oblique prism, its axis is inclined to its base. Axis of a prism is an imaginary line joining the centres of the end faces. Nomenclature of a square prism is shown in Fig. 12.3 and it is self explanatory.

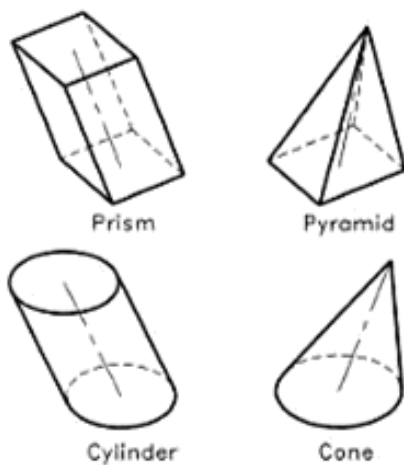

Fig. 12.2 Oblique solids.

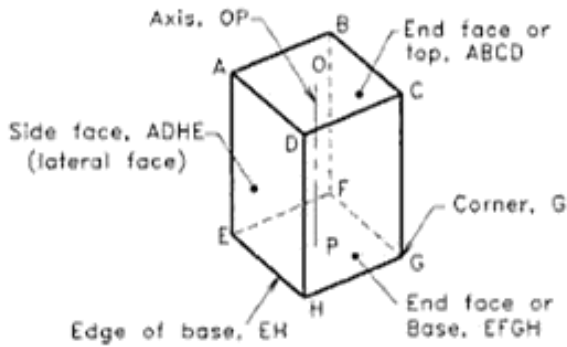

Fig. 12.3 Prism.

Pyramids

A pyramid is a polyhedron having a polygon as base and isosceles triangular faces equal to the number of sides of the polygon, as the lateral faces. They all meet at a point called *apex* or *vertex*. Pyramids are named according to the shape of its base, such as triangular, square, pentagonal, hexagonal, etc.

Nomenclature of a square pyramid is shown in Fig. 12.4 and it is self explanatory. Axis of a pyramid is an imaginary line, joining the vertex to the centre of its base. The perpendicular distance between the vertex and the base of the pyramid is called the *altitude* or *height of the prism*. In the figure, the distance OP is the height. In a right pyramid, its axis is perpendicular to its base; but in an oblique pyramid, its axis is inclined to its base.

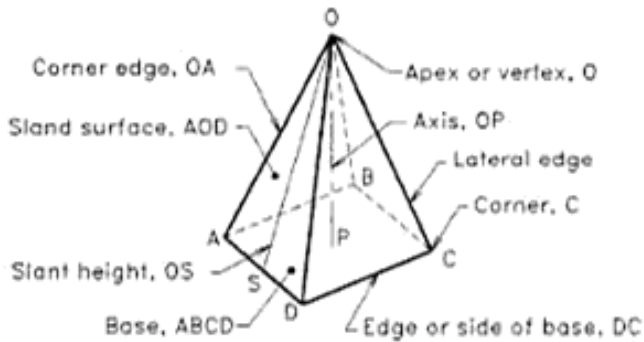

Fig. 12.4 Pyramid.

Solids of Revolution

A solid of revolution is defined as a solid generated by the revolution of a plane figure about a line called *axis*. Cylinders, cones and spheres are some of the solids coming under this group.

Cylinder

A solid generated by the revolution of a rectangle about one

of its sides fixed, is called a *right circular cylinder*. A right circular cylinder is shown in Fig. 12.5. It is generated by the revolution of the rectangle ABOP.

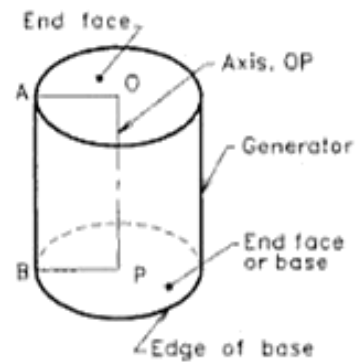

Fig. 12.5 Cylinder.

Cone

A solid generated by the revolution of a right angled triangle about one of its sides, that which remains fixed and contains the right angle, is called *right circular cone*. A right circular cone is shown in Fig. 12.6. It is generated by the revolution of the right angled triangle OPA about OP.

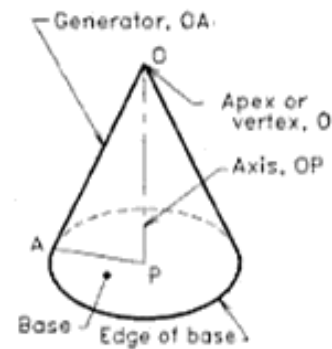

Fig. 12.6 Cone.

Sphere

A solid generated by the revolution of a semicircle about its diameter which remains fixed, is called a *sphere*.

Frustums

If a cone or pyramid is cut by a section plane, parallel to its base, and the portion containing the apex or vertex is removed, then the remaining portion is called *frustum of the cone or pyramid*.

12.2 POSITION OF A SOLID WITH RESPECT TO THE REFERENCE PLANES

The solids under discussion are generally placed in any one of the following ways, based on the inclination of its axes with the reference planes.

1. *Simple position*
 - (a) Axis perpendicular to HP.
 - (b) Axis perpendicular to VP.
 - (c) Axis parallel to HP and VP (i.e. perpendicular to PP).
2. *Axis inclined to one of the reference planes.*
 - (a) Axis parallel to HP but inclined to VP.
 - (b) Axis parallel to VP but inclined to HP.
2. *Axis inclined to both the reference planes.*

The position of solids with reference to the reference planes can also be grouped as:

1. Solid resting on its base.
2. Solid resting on any one of its faces, edges of faces, edges of base, generators, slant edges, etc.
3. Solid suspended freely from one of its corners, edges, etc.

12.3 METHOD OF DRAWING ORTHOGRAPHIC PROJECTIONS OF SOLIDS

The method of drawing orthographic views is similar to that of plane figures. Here, the third dimension i.e. thickness or

height of that object is also considered for drawing. The object is assumed to be placed, unless otherwise specified, in the first quadrant, because first angle projection method is followed. Generally, the projections on the two principal planes are sufficient to describe the object. To fulfil some special requirements, the projection on the profile plane (side view) is also added. Figure 12.7 gives the pictorial view of a square pyramid and its projections on the principal planes. By referring the projections, the following points may be noted:

Rules and Conventions

1. All the rules of projections for points, lines and plane figures are applicable for solids also.
2. Unless otherwise specified, the object is assumed to be contained in the first quadrant, since first angle projection method is followed.
3. If the distance from HP and VP are not given, any convenient distances may be assumed. Similarly, if the direction of the inclination of axis, like towards left or right, towards or away from the observer etc., is not given, any convenient simple position may be selected for drawing.
4. Unless otherwise specified, the views may be drawn by following either *change of position of view method* or *auxiliary projection method*.

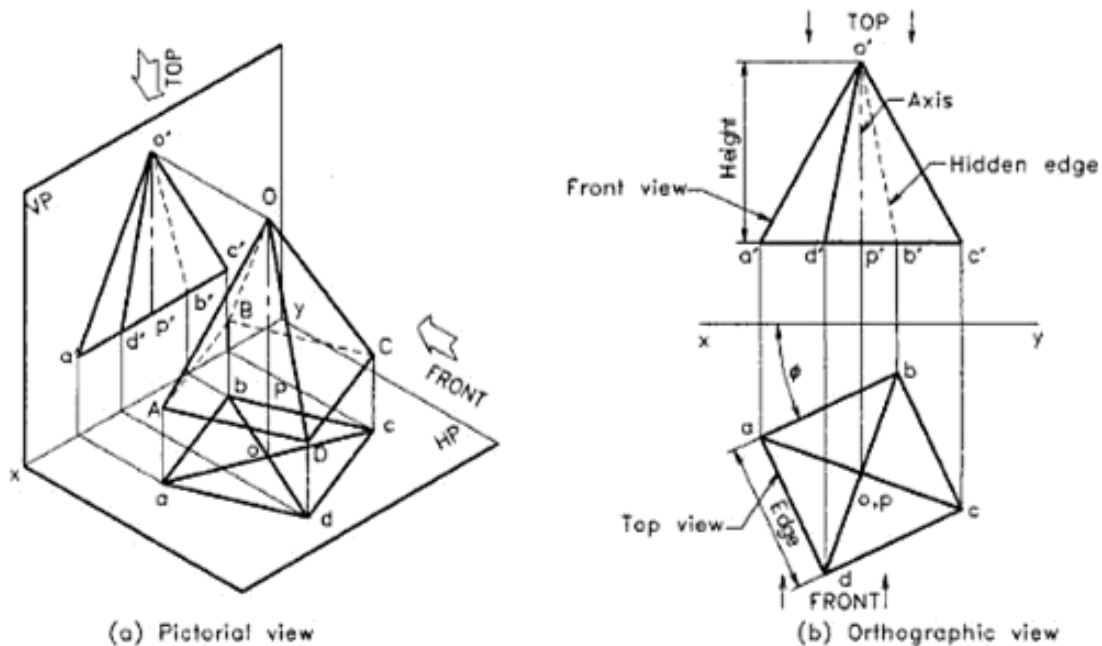

Fig. 12.7 A square pyramid in parallel position.

Urheberrechtlich geschütztes Material

Types of Lines Used and the Order of Priority

1. *Type A line (continuous-Thick)* is used to represent the outline and visible edges of solids.
2. *Type E or F lines (Dashed- thick or thin)* are used to represent hidden outlines or edges.
3. *Type G lines (chain-thin)* are used to represent the axis, lines of symmetry and trajectories.
4. *Type B line (continuous-thin)* is used for all the remaining portions of the drawing like *xy* line, projectors, dimension lines, leader lines, construction lines, etc. Type B line has the least importance compared to the other types of lines.

- Hence it maybe broken or removed partially, for the clarity of the drawing.
5. As mentioned in the Chapter 1, when two or more lines of different types coincide, the order of priority should be:

- | | |
|--------|-----------------------------------|
| First | Type A (continuous- thick) |
| Second | Type E or F (short dashes) |
| Third | Type G (chain-thin) |
| Fourth | Type K (chain-thin double dashed) |
| Fifth | Type B (continuous-thin) |

Figure 12.8 shows orthographic views of solids in simple position.

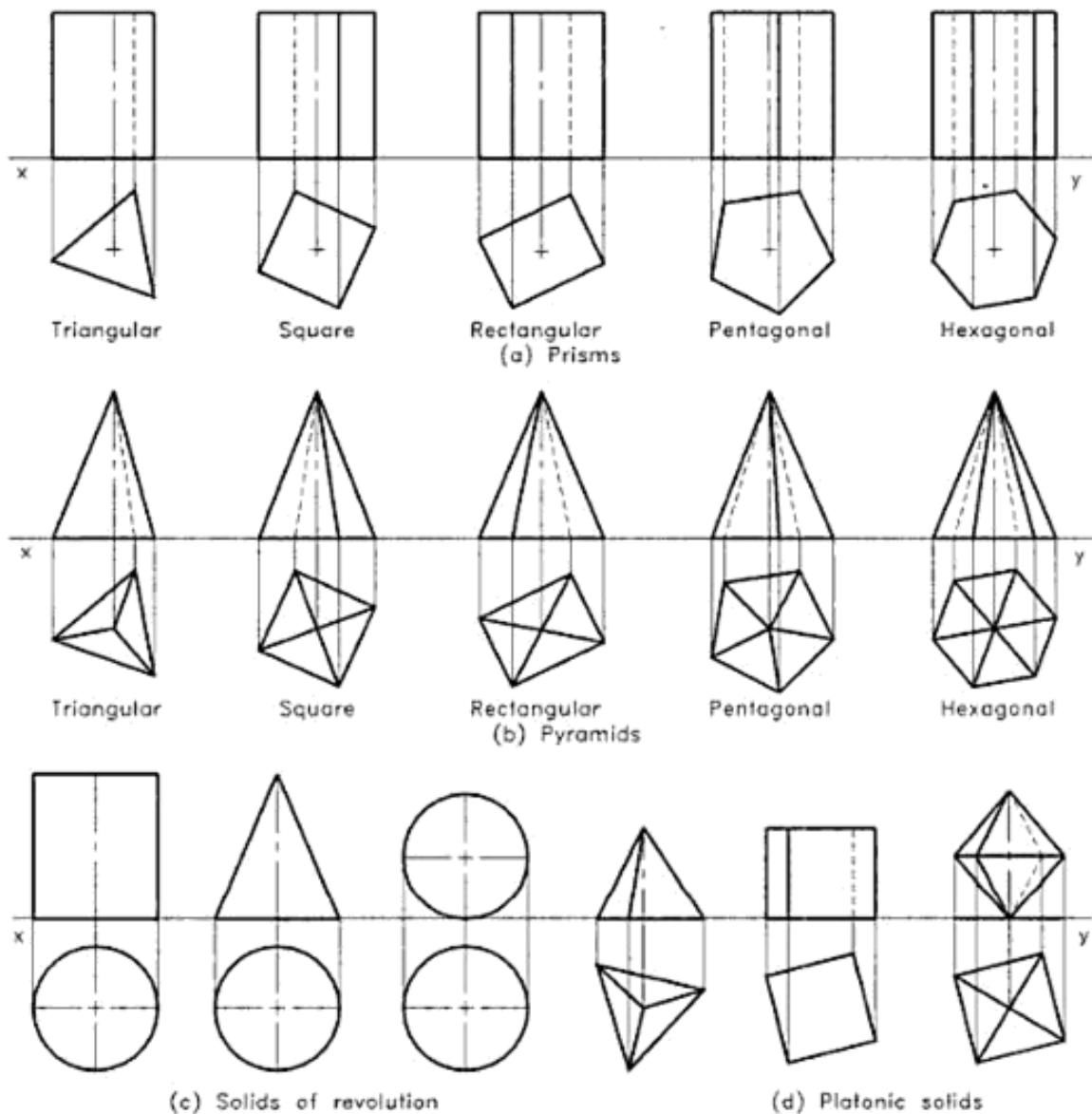

Fig. 12.8 Orthographic views of solids in simple position.

Urheberrechtlich geschütztes Material

Naming of Corners and Dimensioning

The name of corners and axis of the solid are not usually given in questions. But for drawing purpose, it is a good practice to name them systematically. In this text book, the first set of names for corners is given as ABCD, etc. and the second set is given as QRST, etc. These names are given clockwise only for uniformity. The axis is named OP giving O for apex or top end.

The given dimensions should be marked in the views. For this, the view showing the true shape has to be selected. Usually the dimensions of the solid are marked in first set (views in simple position) and the inclinations are shown at the point of its application.

Identification of Hidden Edges

While drawing the views of solids, generally some of the edges are not visible in a view of a solid. These hidden edges will be behind the visible portion and are represented by short dashes.

1. In a view, the outermost lines will be always visible and they form a closed figure of lines or curves i.e. short dashes will not come as outlines but they will be inside only.
2. If a solid has two parallel faces and if one of them is visible, the other parallel face will be hidden.
3. For cones and pyramids, if the apex is pointing to the observer, the base will be hidden.
4. In a projected view, if two lines representing the edges of a solid cross each other, one of the lines will be hidden either completely or partly.

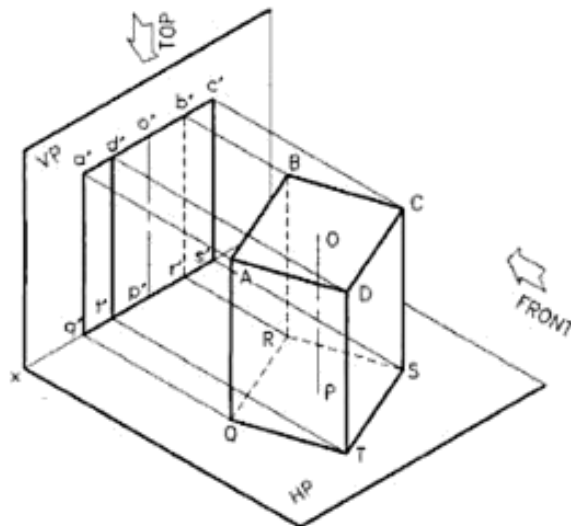

(a) Pictorial view

While viewing a solid, the edges or faces nearby the observer are always visible but the edges or faces behind the solid are hidden. To identify these edges, the orthographic views may be reviewed from top and front sides as shown in Fig. 12.7(b).

12.4 SOLIDS IN SIMPLE POSITION

If a solid is placed in the first quadrant with its axis perpendicular to HP, VP or PP, the position of the solid is considered as in simple position, since the true shape of base and true length of axis are seen in the views. Normally, one set of views will be sufficient to get the answer. The views showing the true shape of the base is drawn first and then projected to the other planes to get the related views. If the axis of the solid is parallel to HP and VP, the true shape of the base is obtained in the end view on PP.

Example 12.1

A square prism of 40 mm side and 60 mm height is resting on HP with one of its rectangular faces inclined at 60° to VP. If the nearest vertical edge is 20 mm in front of VP, draw its projections.

Refer to Fig. 12.9.

1. Draw the xy line. Construct a square of 40 mm side with one side 60° inclined to and the nearest edge 20 mm away from the xy line, as the top view of the prism.
2. Mark the axis position by drawing a cross mark in the direction of the diagonals of the square. Then name the top face corners as $abcd$, the base corners as $qrst$ and axis as op .

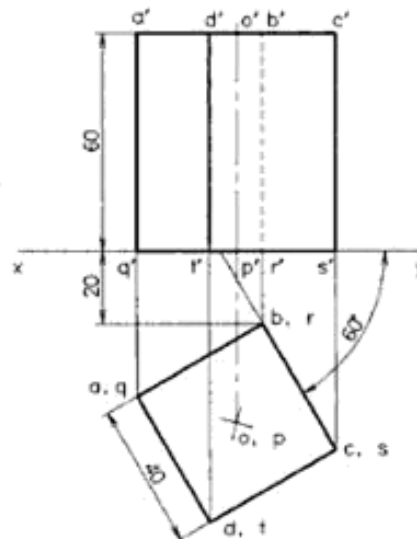

(b) Orthographic views

Fig. 12.9 Projections of a square prism (axis perpendicular to HP).

Urheberrechtlich geschütztes Material

3. Draw vertical projectors up to 60 mm height above the xy line to represent the front view. Name the corners corresponding to the names given in the top view. Finish the outline of the elevation using thick lines. The edge dt is visible in the front view, hence convert $d't'$ to continuous thick line, while the edge br is hidden, and so convert $b'r'$ to short dashes. Draw the axis $o'p'$ using chain line.
4. Finish the view and print the given dimensions to complete the projections.

Example 12.2

A pentagonal pyramid of 30 mm side and axis 60 mm long is resting upon its base on HP such that one of the base edges is perpendicular to VP. If the axis of the pyramid is parallel to and 40 mm away from VP, draw its projections.

Refer to Fig. 12.10.

1. Draw a vertical line ab of 30 mm length and construct a pentagon on it by any method (54° and a circle method is preferred). Mark the corners as $abcde$ and join them to the centre op , to complete the top view.
2. Draw the xy line at 50 mm distance from op and project from all the points of the top view to get the points a', b', c', d', e' , and p' on the xy line.
3. Extend the pp' line to o' so that $o'p' = 60$ mm, to represent the axis of the pyramid. Join the points a', d' and e' to o' , to complete the front view. It is to be noted that hidden edges $b'o'$ and $c'o'$ are coinciding with the visible edges.
4. Finish the view, name the corners and print the given dimensions to complete the drawing.

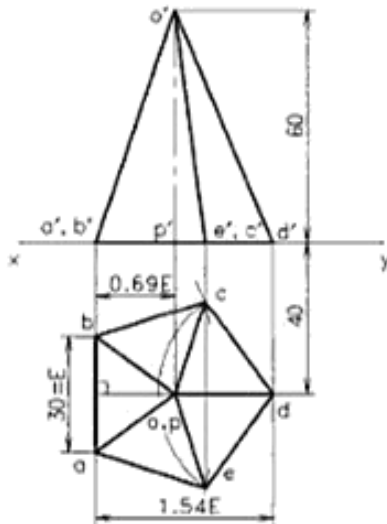

Fig. 12.10 Projections of a pyramid (axis perpendicular to HP).

Example 12.3

A hexagonal pyramid of base side 26 mm and height 64 mm is placed on VP, such that the axis is perpendicular to and the vertex is touching the VP at a height of 40 mm from HP. Draw its projections, if one edge of the base is making 15° to HP.

Refer to Fig. 12.11.

1. Draw xy line and locate the front view of the axis $o'p'$ at 40 mm height from it.
2. Draw a circle of 26 mm radius at $o'p'$ mark the diameter $b'e'$ through that point at an angle of 15° to horizontal. Construct a regular hexagon of side 26 mm on that diameter.
3. Name the corners and drop projectors downwards. Complete the top view keeping the vertex o on xy line.
4. Draw the hidden edges using short dashes and the axis using chain line as shown in figure.
5. Finish the view, name all the corner points and print the given dimensions.

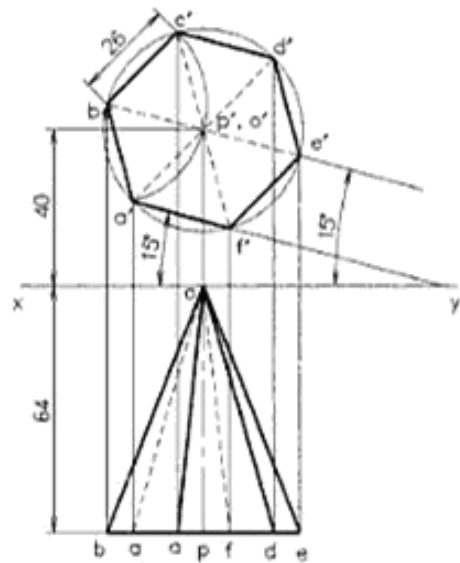

Fig. 12.11 Projections of a pyramid (axis perpendicular to VP).

Example 12.4

An equilateral triangular prism of side 40 mm and length 60 mm has its axis parallel to both HP and VP. Draw its front view, top view and side view on profile plane.

Refer to Fig. 12.12.

1. Draw the xy line horizontally and y_1z vertically as shown in the figure.
2. Since the prism is parallel to HP and VP, the true shape of the prism is obtained in the profile plane pp . Hence, draw an equilateral triangle of 40 mm side as the end view and mark its centre $o''p''$ for the axis position.

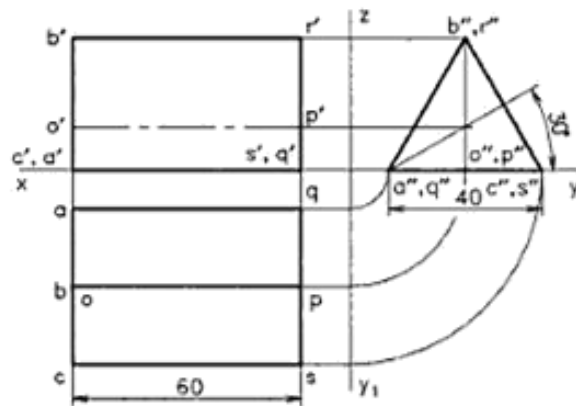
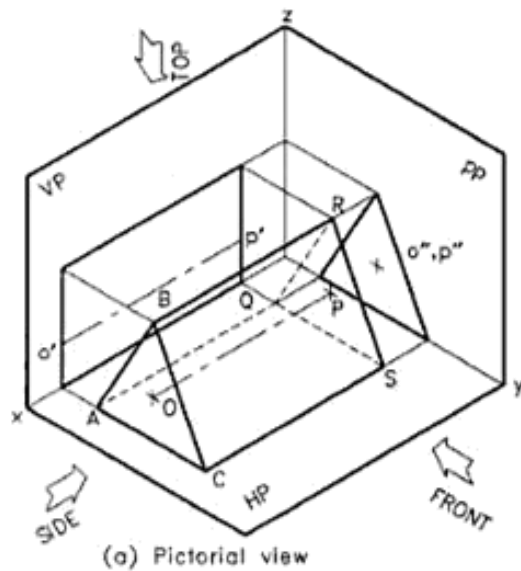

Fig. 12.12 Projections of a triangular prism (axis perpendicular to PP).

3. Project from the end view to get the elevation and plan of the prism as given in figure.
4. Mark the axis in the two views and name the corners.
5. Finish the drawing and enter the given dimensions.

Example 12.5

A frustum of a cone of base diameter 50 mm, top diameter 30 mm and height 44 mm, is placed in the first quadrant such that its axis is parallel to both HP and VP. If the axis is 35 mm above HP, and the base is on the right hand side of the observer, draw its projections.

Refer to Fig. 12.13.

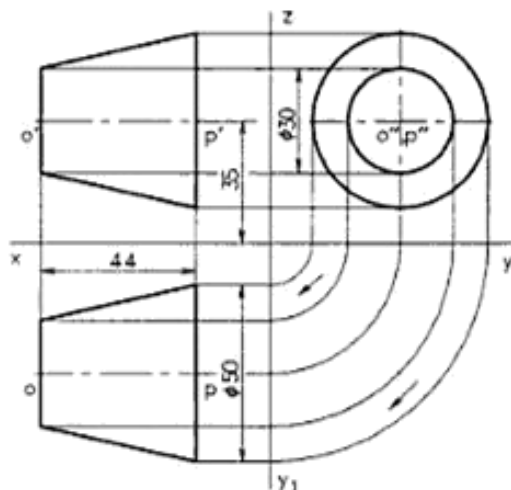

Fig. 12.13 Frustum of a cone.

1. Draw the xy and y_1z lines. Construct two concentric circles of diameters 50 mm and 30 mm at a height of 35 mm to represent the end view of the frustum of the cone as shown in Fig. 12.13.
2. Project from the end view and draw the top and front views.
3. Mark the axis using chain lines, finish the drawing and print the given dimensions.

12.5 AXIS INCLINED TO ONE OF THE REFERENCE PLANES

The drawing of orthographic views of solids with the axis inclined to one of the reference planes and parallel to the other, is similar to that explained for plane figures in Chapter 11. Here, the height of the solid (the third dimension) is also considered. Figure 12.14 gives the views of a square pyramid resting on one of its base edges with the axis inclined to HP.

As explained in the projection of plane figures, the solid is initially kept in simple position, suitable to get the required tilted position, and the first set of views is drawn. In the given example, the solid has to be tilted about a base edge, hence that edge is placed perpendicular to the xy line (may be called as the line for *tilting* LT). Then the front view is tilted and drawn. Project vertically from the new front view and horizontally from the previous top view to get the points of intersection for the required top view. This method of projection may be termed as *change of position method*. The second set of views gives the required projections.

Example 12.6

A square pyramid of 50 mm base and 70 mm height is resting on one of its base edges on HP. If the axis is parallel to VP and inclined 45° to HP, draw its projections.

Refer to Fig. 12.14.

1. Draw the xy line and construct a square of 50 mm at a convenient distance from it to get the top view. Here the base edge cd is kept perpendicular to xy line and it is used as the line for tilting LT.
2. Project upwards from the top view and complete the front view as the 2nd.
3. Copy the front view keeping the edge $c'd'$ on xy line and the base making 45° so that, the axis is inclined 45° to HP. This is the 3rd view.
4. Project vertically downwards from the 3rd view and horizontally from the 1st view to get the intersection points of the 4th view.
5. Convert the outermost lines and the edges representing the top triangular surface into visible edges. But the crossing line $c'd'$, which is below, is converted as hidden edge.
6. Finish the views, name all the corners and print the given dimensions to complete the drawing.

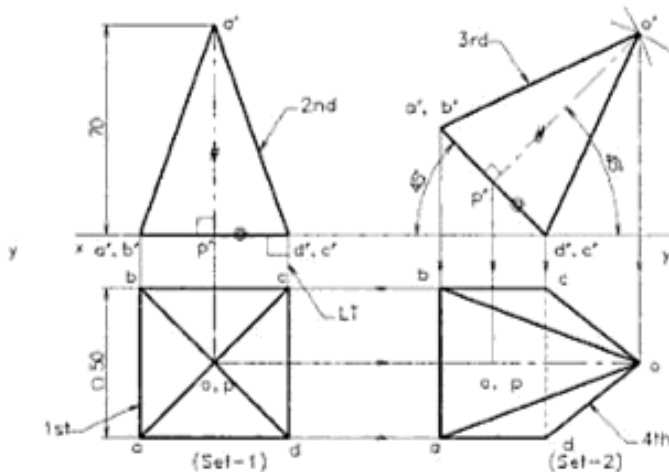

Fig. 12.14 Square pyramid (axis inclined to HP).

Example 12.7

A hexagonal prism of base side 26 mm and height 60 mm rests with one of its rectangular faces on HP. If the axis is inclined at 30° to VP, draw its projections.

Refer to Fig. 12.15.

1. Draw the xy line. Place the prism in the simple horizontal position keeping one rectangular face on HP. The final required inclined position is obtained

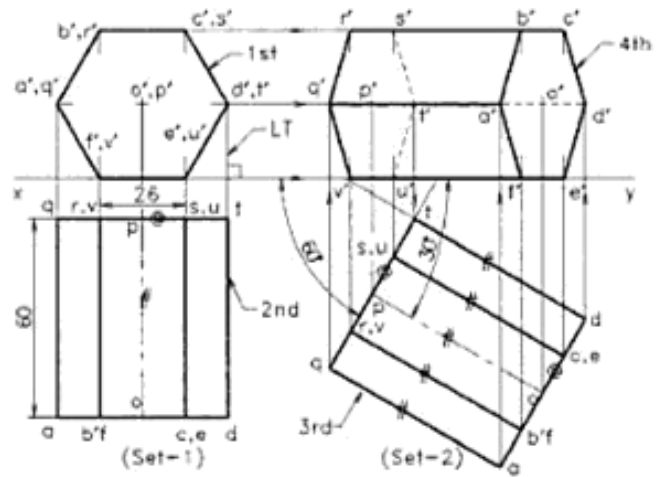

Fig. 12.15 Drawing board with minidrafter clamped

- by tilting the solid about the line for tilt LT. Draw the front view and then the top view as the 2nd.
2. Copy the top view after rotating, so that the axis makes 30° with VP. This is the 3rd view.
3. Project upwards from the 3rd view and project horizontally from the 1st view, so that their intersection points give the final 4th view.
4. Convert the outermost edges of 4th view to thick lines. Look to the top view (3rd) from the front side and identify the visible face $abcde$. Convert this face as visible one in the elevation (4th), while the parallel face as hidden. Also note that in the view, the line $f'd'$ is representing a hidden edge. Since the visible edge $q'a'$ is coinciding with the hidden edge from f' to d' , only the line $d'a'$ is to be drawn in short dashes.
5. Finish the views, name all the corners and print the given dimensions to complete the drawing.

Example 12.8

A regular pentagonal pyramid has an altitude of 60 mm and base side 30 mm. The pyramid rests with one of its sides of the base on HP such that the triangular face containing that side is perpendicular to both HP and VP. Draw its projections.

Refer to Fig. 12.16.

1. Since one of the triangular slant surfaces of the pyramid is to be perpendicular to HP, the pyramid has to be kept initially in simple vertical position, and one of the base edges cd perpendicular to VP. Draw the top and front views.
2. Redraw the front view, keeping the face $o'd'c'$ perpendicular to xy line. For this, first draw the line

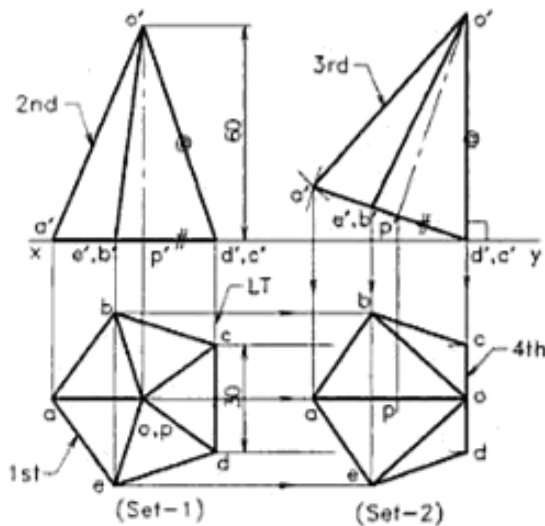

Fig. 12.16 Pentagonal pyramid (slant surface perpendicular to HP).

3. Project horizontally from the first view and vertically from 3rd view so that the intersections of the lines locate the corners of the 4th view. It is to be noted that, the triangular face odc is perpendicular to both HP and VP.
4. Finish the view, name the corners and print the given dimensions.

Example 12.9

A cone of base 50 mm diameter and axis 60 mm long has one of its generators on HP. If the axis is parallel to VP, draw its projections.

Refer to Fig. 12.17

1. Draw the projections of the cone, keeping the base on HP.
2. Divide the top view, which is a circle, radially into 12 equal parts and mark its diameter as ac and bd in top view and in front view.
3. Copy the front view, so that the generator $o'c'$ is on the xy line. For this, mark the distance $o'c'$ on xy line and construct the triangle $a'o'c'$ on it. Draw the axis $o'p'$ and mark the generators on the 3rd view.
4. Project horizontally from the first view and vertically from the 3rd view, to get the various points of the 4th view. Here, the circular base is seen as an ellipse. Draw the ellipse by joining the points using french curves or by freehand drawing. Then draw two tangents from the apex o to the ellipse to represent the outermost generators. It is to be noted

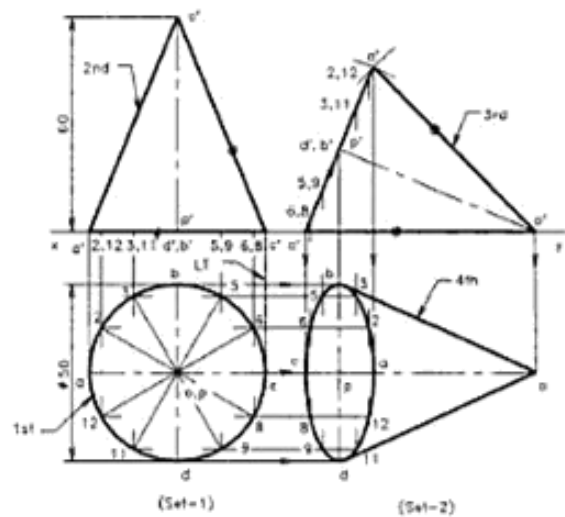

Fig. 12.17 Cone (A generator on HP).

- that, in this position all the edges are visible in all the views.
5. Finish the drawing and print the given dimensions.

Example 12.10

A cylindrical disc of 60 mm diameter and 40 mm length is resting upon one of its generators on HP. If the axis of the cylinder makes 60° to VP, draw its projections.

Refer to Fig. 12.18.

1. Draw front and top views of the cylinder, keeping one of the generators on HP and the axis perpendicular to VP.
2. Divide the front view, which is a circle, radially into 12 equal parts and name them clockwise. Also name the horizontal and vertical diameters as $a'c'$, $g'd'$, $q's'$, etc. in front view and the same in top view.
3. Copy the top view and generators after rotating it, so that the axis makes 60° with the xy line.
4. Project horizontally from the first front view and vertically from the 3rd view, so that the points of intersection of lines form the 4th view.
5. In the 4th view the front face $abcd$ of the disc is visible ellipse, while the rear face $qrst$ is hidden. The edge $t'q't'$ is visible because it is the outermost edge, but the edge $r's'r'$ is hidden, hence it should be represented by short dashes. Join the points by drawing smooth curves either using suitable french curves or freehand.
6. Finish the view, name the corners and print the dimensions.

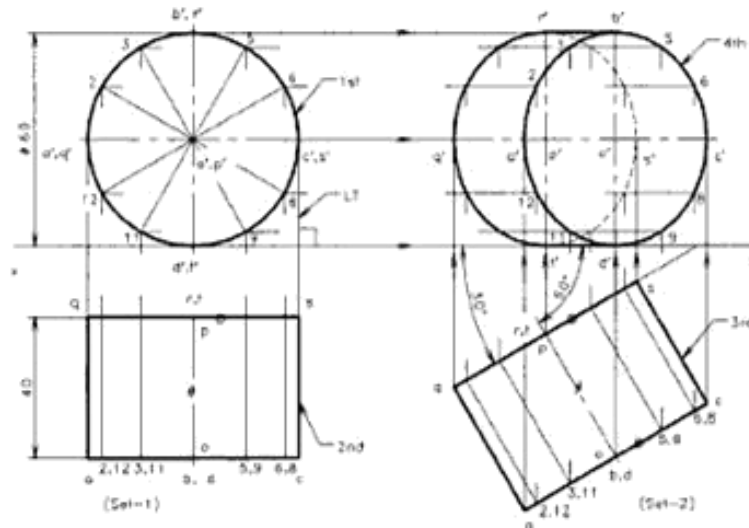

Fig. 12.18 Cylindrical disc (axis inclined to VP).

Example 12.11

A triangular pyramid of base side 40 mm and axis 56 mm long is freely suspended from one of the corners of its base. Draw its projections, if the axis is parallel to VP.

Refer to Fig. 12.19.

1. Draw the top and front views of the pyramid, keeping the base on HP and one of the base edges (say *bc*) perpendicular to the *xy* line. This position brings the line joining the point of suspension and the centre of gravity *ag* parallel to VP.

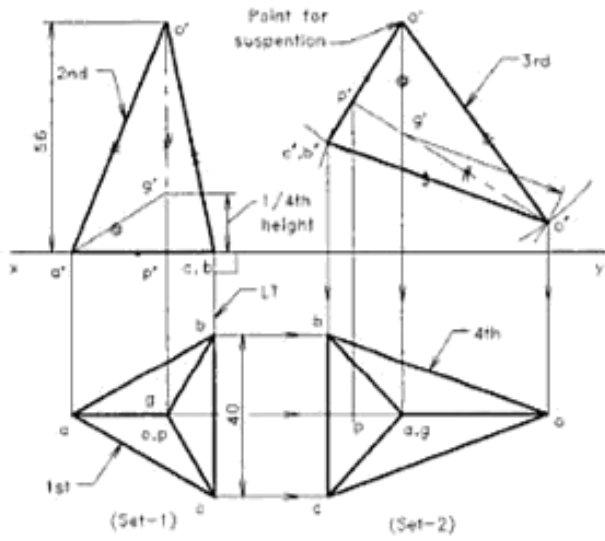

Fig. 12.19 Suspended triangular pyramid (axis inclined to HP).

2. For all pyramids and cones the centre of gravity is located at 1/4 th the height from the base. Therefore mark the centre of gravity of the solid in the front view as *g'*.
3. Join the corner *a'* to *g'*. If the pyramid is suspended from the corner *a'*, the line *a'g'* will be perpendicular to the *xy* line in the front view. Hence, copy the first front view, keeping the line *a'g'* vertical. For this, draw a line perpendicular to *xy* and mark the distance *a'g'* on it. Construct the triangle *a'o'g'* on that line and then the triangle *a'o'b'*, to complete the 3rd view.
4. Project horizontally from the first top view and vertically from the 3rd view, to get the points of the 4th view. Here, all the edges are visible.
5. Finish the view, name the corners and print the dimensions.

Example 12.12

A frustum of a square pyramid of base side 32 mm, top side 16 mm and height 40 mm is resting on one of its base corners, such that the base is 45° inclined to HP. Draw the projections. Refer to Fig. 12.20.

1. Since the base edges are to be at equal inclinations to HP, the solid has to be kept initially in the simple position, so that the sides are at equal inclinations to the projector *cc'* (LT). Draw the top view and then the front view.
2. Copy the front view after tilting the view about the corner *c'* so that the base makes 45° inclination with

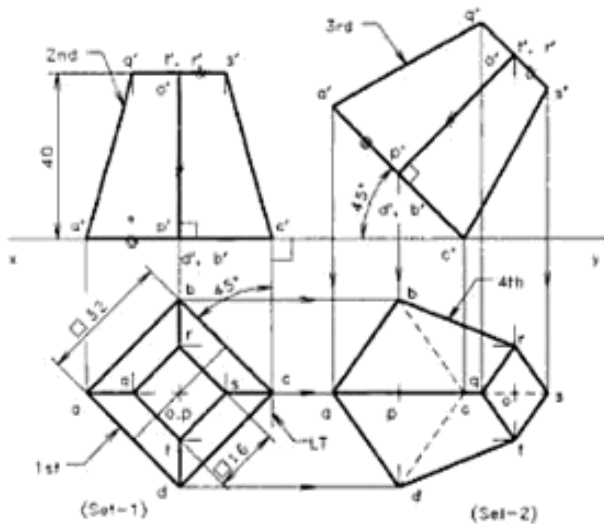

Fig. 12.20 Frustum of a pyramid (axis inclined to HP).

the xy line. This can be done by drawing $c'o'$ at 45° and copying the front view on it.

3. Project horizontally from the first top view and vertically from the 3rd view to get the points of intersection which represents the corners of the 4th view.
4. Identify the hidden lines and join the edges with proper lines.
5. Finish the view, name the corners and print the given dimensions.

12.6 AXIS INCLINED TO BOTH THE REFERENCE PLANES

When the axis of a solid is inclined to both the reference planes, its projected views are usually obtained in three stages of projection, following the *change of position method*. This is an extension of the procedure followed in the previous sections. The three sets of views to be completed are:

Set-1 The axis of the object is kept in simple position (i.e. perpendicular to one of the reference planes), suitable to reach the final required position, and the first set of views (1st and 2nd) are drawn.

Set-2 The object is tilted to bring the axis inclined one of the reference planes and parallel to the other. Then the second set of views (3rd and 4th) are drawn.

Set-3 The object is further tilted to bring the axis inclined to both the reference planes. The third set of views (5th and 6th) are drawn now to get the answer.

The change of position method is similar to the one explained in projections of plane figures. Here, a total of six views are generally drawn to satisfy the required conditions. Figure 12.21 gives the projections of a square pyramid with axis inclined to both the reference planes. If the direction of inclination is not specified in the question, the tilting of the solid can be in the opposite direction also. Similarly, the apex of the pyramid may be directing towards or away from the VP. This will result in three more different solutions. Figure 12.22 shows these three possible (Set-3) solutions. It is to be noted that, as the direction of tilting is different for the

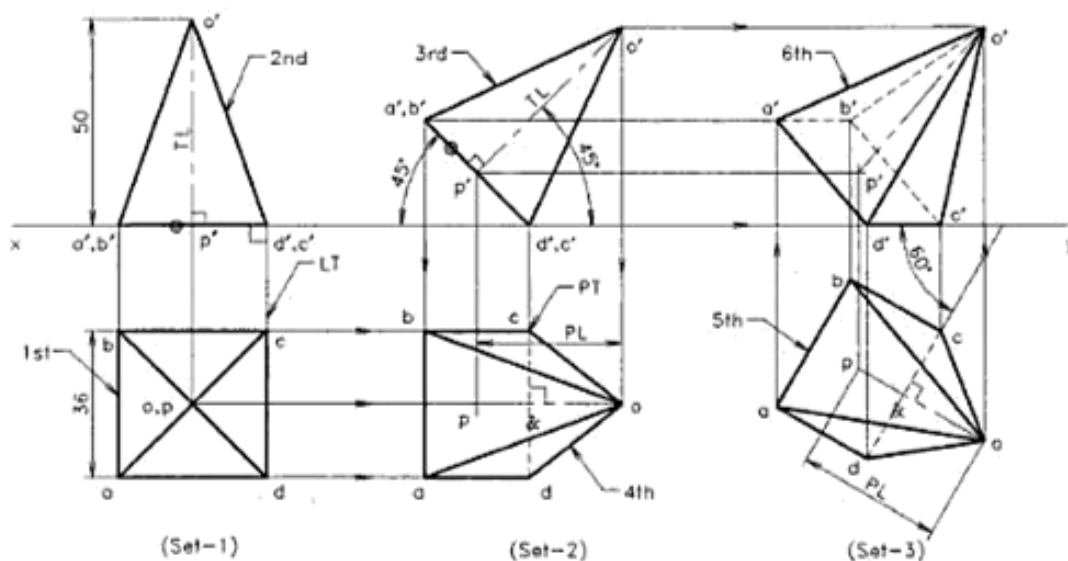

Fig. 12.21 A square pyramid (axis in oblique position—apex pointing towards right and away from VP).

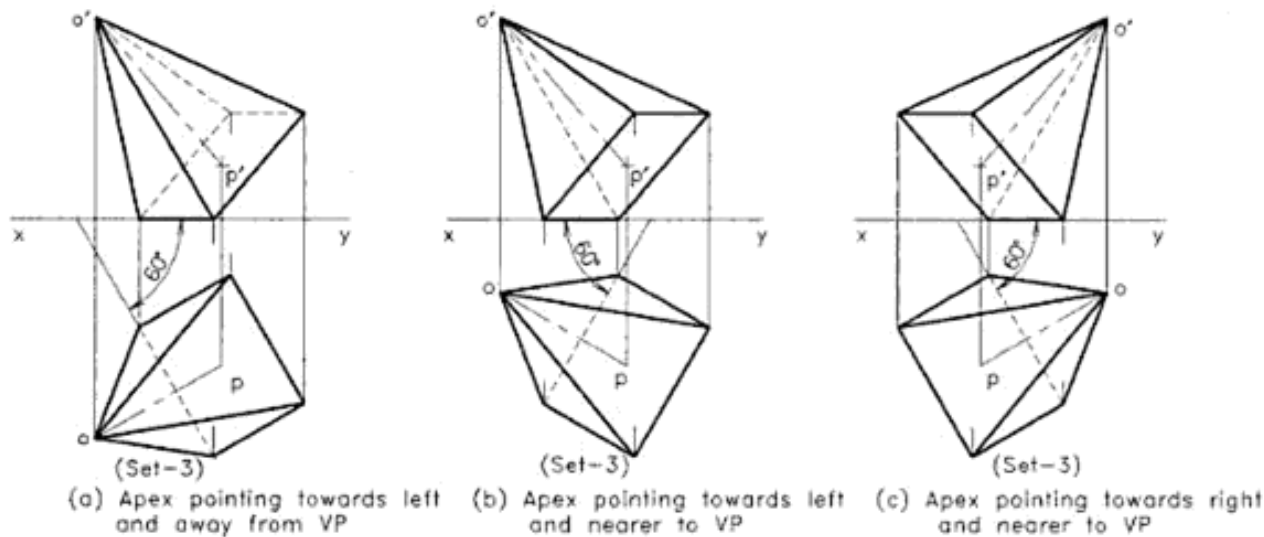

Fig. 12.22 A square pyramid—the three different solutions.

same angle of inclination, the visible and hidden edges are interchanged. The following examples explain the procedure of drawing various solids in oblique positions.

Example 12.13

A square pyramid has its axis inclined at 45° to HP and one edge of its base is inclined at 60° to VP. If the length of the edge of its base is 36 mm and the height is 50 mm, draw the projections of the object, keeping one of the edges of its base on HP.

Refer to Fig. 12.21.

1. Draw the projections of the pyramid, keeping the base on HP and one of the base edges (LT) perpendicular to VP.
2. Copy the front view after tilting the axis by 45° to the xy line. Project horizontally from the top (1st) view and vertically from the second front (3rd) view to get the second top (4th) view.
3. Produce the second top view, keeping the edge cd inclined at 60° to the xy line (turn the top view about point c , the point of turning PT) to get the third top (5th) view. Project horizontally from the second front view (4th) and vertically from all the points on the third top view (5th) to locate the corners of the third front (6th) view.
4. Join the points of intersection using continuous thick lines for visible edges and short dashes for hidden edges. The method for identification of visible and hidden edges are the same as that explained in article 12.3 of this chapter.

5. Finish the three sets of views, name the corners and print the given dimensions.

Figure 12.22 gives three more solutions (final set of views) to the same question. Note that the hidden edges are changed as the direction of inclination changes. It can be identified by looking from the front side of the top view. As the apex points the observer the base cannot be seen.

Example 12.14

A square prism of base side 30 mm and height 50 mm has its axis inclined at 35° to VP and has a base edge on VP, inclined at 45° to HP. Draw its projections.

Refer to Fig. 12.23.

1. Draw the projections of the square prism, keeping the axis perpendicular to VP and one edge of base on VP, perpendicular to xy line (LT).
2. Copy the top view (2nd), after tilting the axis to make 35° to the xy line. The edge st of the base is placed on VP. Project horizontally from the front (1st) view and vertically from the second top (3rd) view to get the second front (4th) view.
3. Reproduce the second front (4th) view, keeping the edge $s't'$ inclined at 45° to the xy line, to get the third front (5th) view. Project horizontally from the second top (3rd) view and vertically from the third front (5th) view, to get the third top (6th) view.
4. Join the points of intersection using continuous thick lines for visible edges and short dashes for hidden edges as explained in Section 12.3.
5. Finish the three sets of views, name the corners and print the given dimensions.

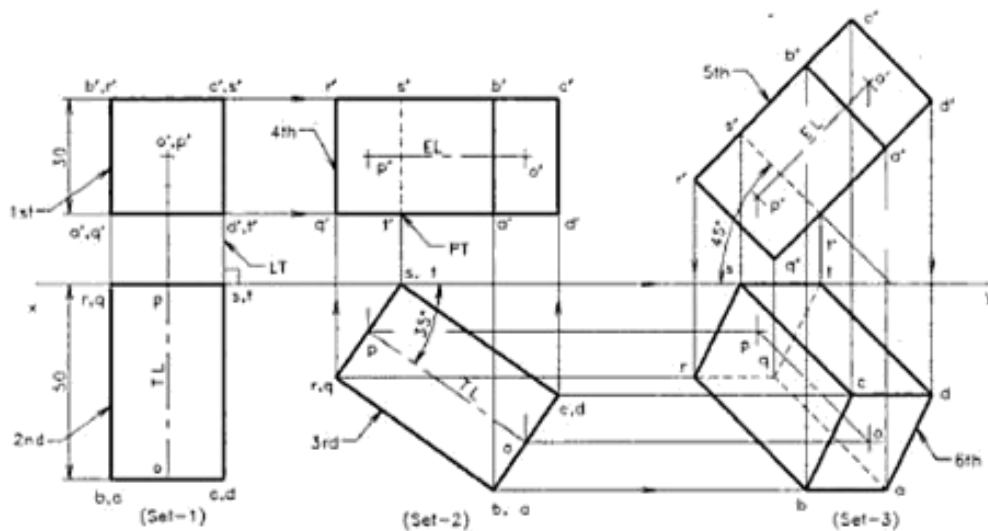

Fig. 12.23 A square prism (axis in oblique position).

Example 12.15

A cone, of base diameter 50 mm and 60 mm height, has one of its generators on HP. If the axis of the cone is seen as 45° inclined to xy line in the top view and the apex is nearer to VP, draw the projections of the cone.

Refer to Fig. 12.24.

1. Keeping the base on HP, draw the projections of the cone in simple position. Divide the base circle radially into 12 equal parts and name these generators as given in figure.

2. Copy the front (2nd) view, keeping the generator $o'c'$ on the xy line. Project horizontally from the top view and vertically from the second front view to get the second top (4th) view as explained in Example 12.9.
3. Reproduce the second top (4th) view, so that the axis of the view is 45° inclined to the xy line and the apex is nearer to it. Here, the ellipse has to be copied by measuring and marking the major and minor axes as well as the intermediate line lengths

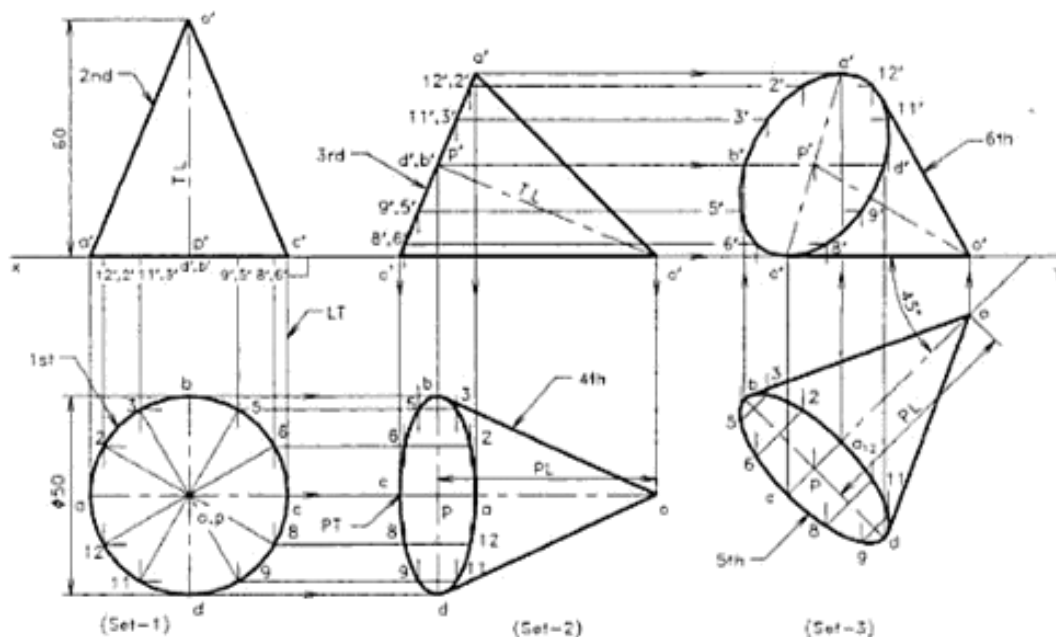

Fig. 12.24 A cone (axis in oblique position).

Urheberrechtlich geschütztes Material

connecting the 12 points perpendicular to the major axis. This gives the third top (5th) view.

- Project horizontally from the second top (3rd) view and vertically from the third top (5th) view to form the third front (6th) view. It is to be noted that for cones, the outer most generator has to be drawn in all these views. To obtain the outermost generators, draw tangents from the apex to the ellipse, which represents the base of the cone.
- Finish the three sets of views, name the points and print the given dimensions.

Example 12.16

Draw projections of a pentagonal pyramid 30 mm side and axis 60 mm long, when it is resting on one of its base edges with

- the axis making an angle of 30° with HP and the top view of the axis making 45° with VP, and
- the axis making an angle of 30° with HP and 45° with VP.

Refer to Fig. 12.25.

- Here, the first two sets of views are the same for the two given (a and b) conditions. Therefore, draw the first set of projections of the pyramid, keeping the base on HP and one of the base edges (LT) perpendicular to VP.

- Copy the front view keeping the axis inclined at 30° to the xy line. Project horizontally from the top view and vertically from the second front view to get the second top view.

Solution to (a) part

- As per the given conditions in part (a), the axis of the top view makes 45° to the xy line. This means the angle given is the apparent angle β and equal to 45° . Hence, reproduce the second top view keeping the axis of the view 45° inclined to the xy line, to get the third top view. Project horizontally from the second front view and vertically from the third top view to get the third front view.

Solution to (b) part

- In this part the angle of inclination of the axis is 45° with VP. This means the given angle is the true inclination ϕ and not the apparent angle. Hence to proceed, the apparent angle β (the angle seen in the projection, which is always larger than the true angle), has to be determined graphically. To find the apparent angle β , do the geometrical construction near by the view. Draw a line po_1 = the true length TL of the axis, at the true angle 45° to VP and mark the locus line vv parallel to xy line, passing through o_1 . With centre p , cut an arc of

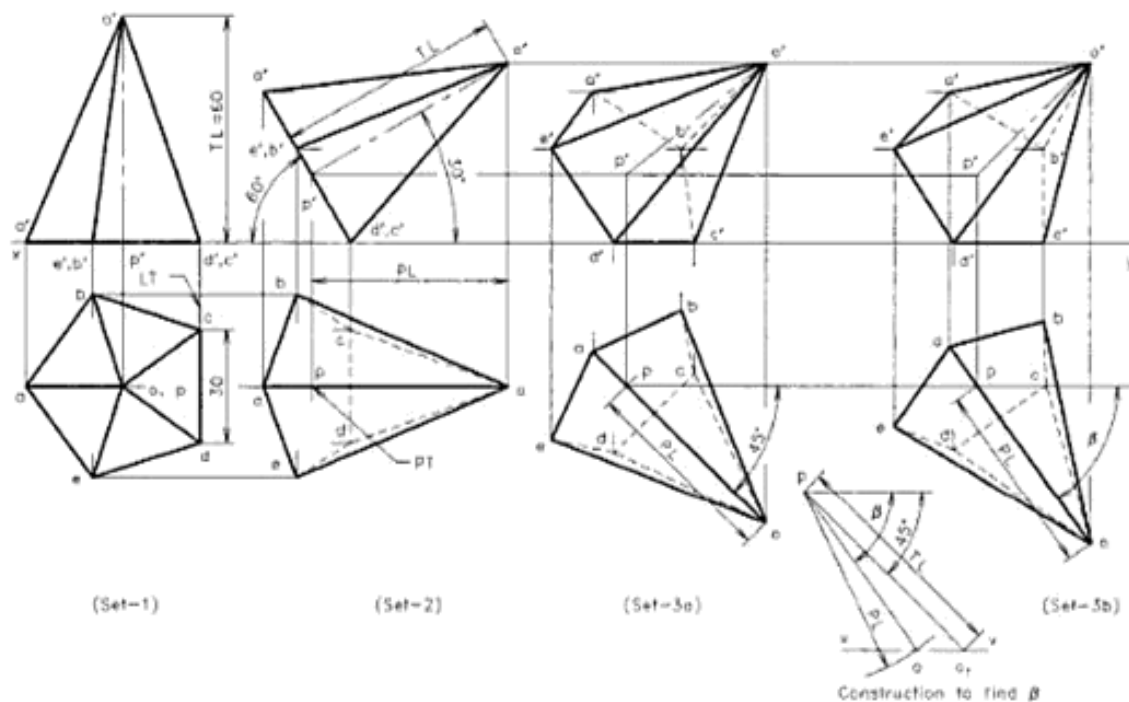

Fig. 12.25 A pentagonal pyramid (axis inclined to both the reference planes).

radius equal to the plan length PL of the axis (op of the second top view) on the locus line vv . The inclination of line po gives the angle β to the horizontal.

5. Reproduce the second top view at this angle β to the xy line in order to get the fourth top view.
6. Project horizontally from the second front view and vertically from the fourth top view, to get the fourth front view. This set of views is marked as Set-3b. It is to be noted that the third and fourth front views are almost similar but not exactly the same.
7. Finish the four sets of views with proper lines and print the given dimensions.

While solving a problem of solid in oblique position, the student has to identify from the question, whether the given second angle of inclination is the true angle or the apparent angle. If it is the true angle the apparent angle has to be determined.

Example 12.17

A square pyramid of base side 32 mm, axis 56 mm long, is suspended freely from one of the corners of its base. If a vertical plane containing the axis is seen 60° inclined to the xy

line in the top view, draw the projections of the suspended pyramid.

Refer to Fig. 12.26.

1. Draw the projections of the square pyramid keeping the base on HP. Let the point of suspension is the corner a of the base on left side. The centre of gravity g of the pyramid is on the axis at $1/4$ th height from the base. The line joining a and g in the first top view should be kept parallel to the xy line initially. Hence, place the base edges of square pyramid equally inclined (45°) to the line for tilting LT.
2. Draw the first front view and mark the centre of gravity g' of the pyramid at $1/4$ th height from the base. Join a' to g' . If the solid is suspended from corner a' , the line $a'g'$ will be seen perpendicular to the xy line in the second front view. Hence, copy the first front view, keeping the line $a'g'$ vertical. The copy can be made on $a'g'$; by considering the view as a combination of triangles as explained in Example 12.11.
3. Project horizontally from the top view and vertically from the second front view to get the second top view.

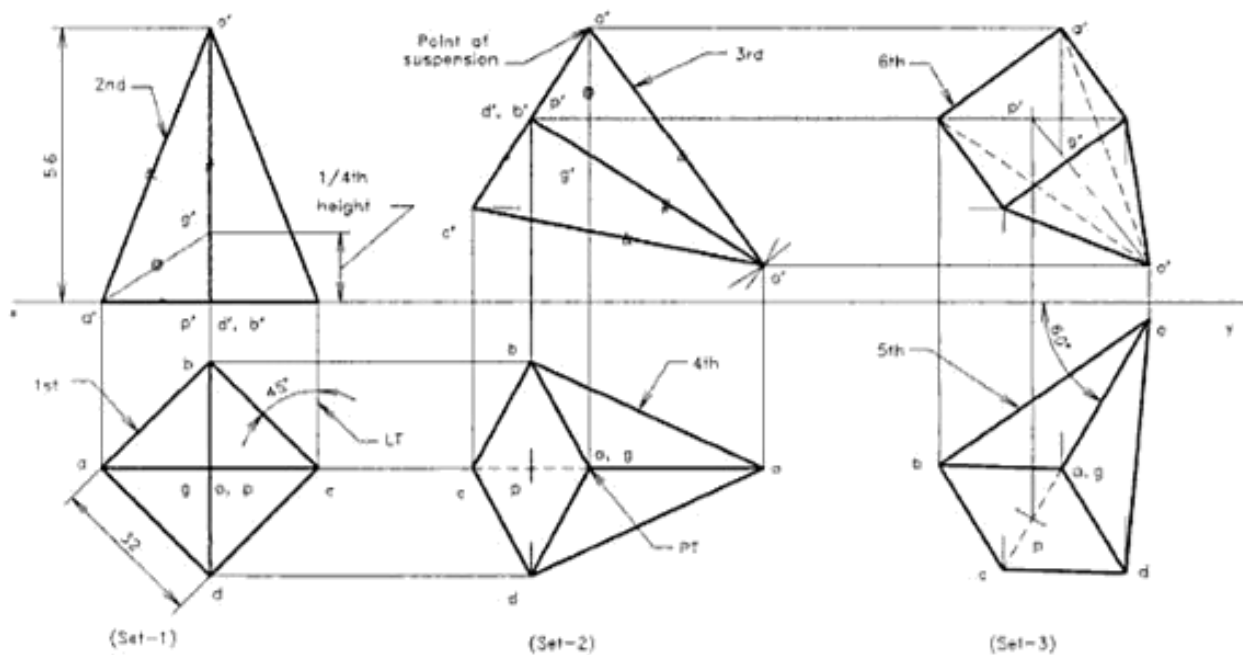

Fig. 12.26 A suspended square pyramid.

- Since the axis is lying in a vertical plane, inclined at 60° to VP, the apparent angle of the axis to the xy line also 60° . So, redraw the second top view, keeping the axis inclined at 60° to the xy line, to get the third top view.
- Project horizontally from the second front view and vertically from the third top view, to get the third front view.
- Finish the views, name the corners and print the given dimensions.

Example 12.18

Draw front, top and side views of a square pyramid of base side 34 mm and axis 40 mm long such that the axis is inclined 40° to VP and 50° to HP. One base edge is on HP and the apex of the pyramid is kept near by VP than the base.

Refer to Fig. 12.27.

- The total of the true inclinations of the axis ($40 + 50$) is 90 . That means the axis is parallel to PP and hence the true angles and TL will be seen in the

side view. If the usual procedure is followed, first draw the plan and elevation of the pyramid in simple position keeping one base edge perpendicular VP.

- Tilt solid to 50° in the elevation and get the second top view by projecting downwards.
- Copy this second plan (4th) after turning 90° anticlockwise about PT. Project upwards from the third plan (5th) and draw horizontal lines from the second elevation to get the third (6th) front view.
- Now the pyramid is in the required position. Draw zy_1 line perpendicular to xy line and get the side view on the profile plane as shown in the figure.
- Finish the views and print the given dimensions.

If the student can visualise the position of the pyramid in the side view without confusion, that view (7th) can be drawn directly on PP using the given true angles and lengths. Then the required elevation and plan can be obtained by projecting backwards to VP and HP. Thus the solution is completed in three views instead of seven.

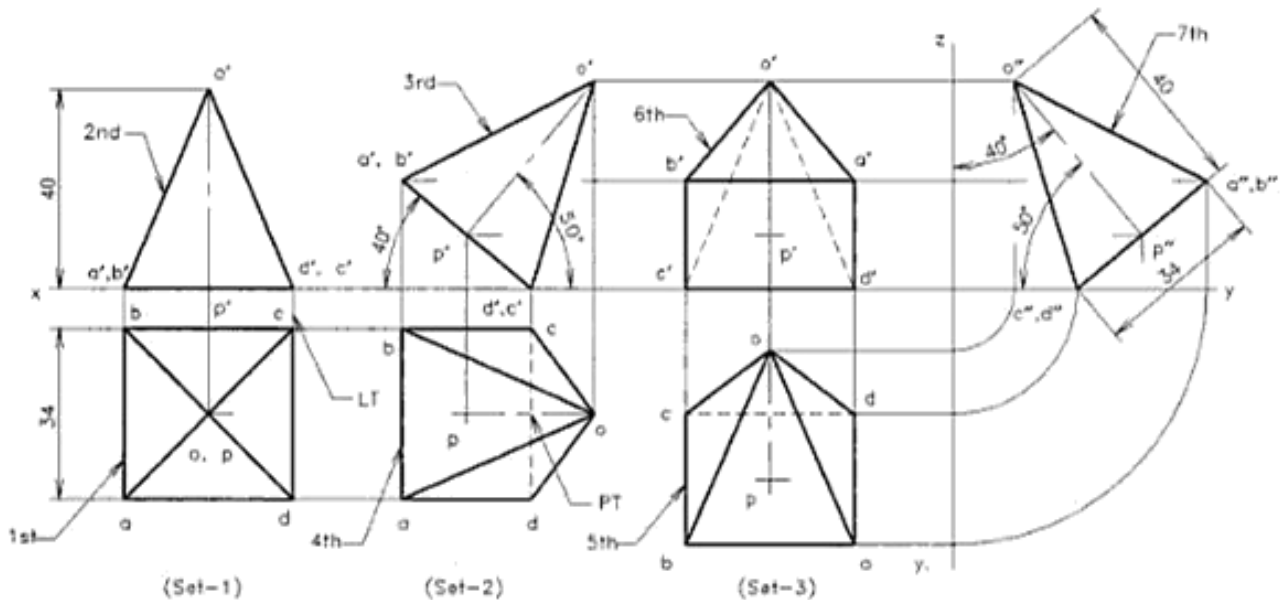

Fig. 12.27 Three views of a square pyramid in oblique position.

EXERCISES

(# Problems similar to the worked-out examples)

Solids in simple position

- A square prism of 50 mm side and 70 mm height is resting on HP with one of its rectangular faces inclined at 65° to VP. If the nearest vertical edge is 25 mm in front of VP, draw its projections. (#)
- A pentagonal pyramid of 40 mm side and axis 75 mm long is resting upon its base on HP such that one of the

Urheberrechtlich geschütztes Material

base edges is perpendicular to VP. If the axis of the pyramid is parallel to and 60 mm away from VP, draw its projections. (#)

3. A hexagonal pyramid of base side 30 mm and height 70 mm is placed on VP, such that the axis is perpendicular to and the vertex is touching the VP at a height of 50 mm from HP. Draw its projections, if one edge of the base is making 10° to HP. (#)
4. An equilateral triangular prism of side 45 mm and length 70 mm has its axis parallel to both HP and VP. Draw its front view, top view and side view on profile plane. (#)
5. A frustum of a cone of base diameter 46 mm, top diameter 26 mm and height 40 mm, is placed in the first quadrant such that its axis is parallel to both HP and VP. If the axis is 36 mm above HP, and the base is on the right hand side of the observer, draw its projections. (#)
6. A frustum of a square pyramid of base side 40 mm, 25 mm top side and height 50 mm is placed in the first quadrant such that its axis is parallel to both the reference planes. If the axis is 36 mm above HP, and the base is on the right hand side of the observer, keeping the base edges at equal inclination to VP, draw the projections.

Axis inclined to one of the reference planes

7. A square pyramid of 40 mm base and 60 mm height is resting on one of its base edges on HP. If the axis is parallel to VP and inclined 30° to HP, draw its projections. (#)
8. A pentagonal prism of base side 30 mm and height 70 mm rests with one of its rectangular faces on HP. If the axis is inclined at 30° to VP, draw its projections. (#)
9. A regular hexagonal pyramid has an altitude of 60 mm and base side 26 mm. The pyramid rests with one of its sides of the base on HP such that the triangular face containing that side is perpendicular to both HP and VP. Draw its projections. (#)
10. A cone of base 60 mm diameter and axis 70 mm long has one of its generators on HP. If the axis is parallel to VP, draw its projections. (#)
11. A cylindrical disc of 64 mm diameter and 40 mm length is resting upon one of its generators on HP. If the axis of the cylinder makes 45° to VP, draw its projections. (#)
12. A triangular pyramid of base side 50 mm and axis 60 mm long is freely suspended from one of the corners of

its base. Draw its projections, if the axis is parallel to VP. (#)

13. A frustum of a square pyramid of base side 40 mm, top side 20 mm and height 50 mm is resting on one of its base corners, such that the base is 30° inclined to HP. Draw the projections. (#)
14. A cone of base 50 mm diameter and axis 60 mm long has one of its generators on VP. If the axis is parallel to HP, and pointing left side, draw its projections.
15. A pentagonal prism of base side 30 mm and axis 60 mm long is freely suspended from one of the corners of its base. Draw its projections, if the axis is parallel to VP.

Axis inclined to both the reference planes

16. A square pyramid has its axis inclined at 30° to HP and one edge of its base is inclined at 45° to VP. If the length of the edge of its base is 40 mm and the height is 60 mm, draw the projections of the object, keeping one edge of its base on HP. (#)
17. A triangular prism of base side 40 mm and height 50 mm has its axis inclined at 40° to VP and has a base edge on VP, inclined at 50° to HP. Draw its projections. (#)
18. A cone, of base diameter 52 mm and 64 mm height, has one of its generators on HP. If the axis of the cone is seen as 30° inclined to xy line in the top view and the base is nearer to VP, draw the projections of the cone. (#)
19. Draw projections of a hexagonal pyramid 26 mm side and axis 60 mm long, when it is resting on one of its base edges with,
 - (a) the axis making an angle of 35° with HP and the top view of the axis making 40° with VP, and
 - (b) the axis making an angle of 35° with HP and 40° with VP. (#)
20. A square pyramid of base side 36 mm, axis 60 mm long, is suspended freely from one of the corners of its base. If a vertical plane containing the axis is seen 50° inclined to the xy line in the top view, draw the projections of the suspended pyramid keeping the apex away from VP than its base. (#)
21. Draw front, top and side views of a pentagonal pyramid of base side 30 mm and axis 50 mm long such that the axis is inclined 35° to VP and 55° to HP. One base edge is on HP and the apex of the pyramid is kept nearby VP than the base. (#)

Sections of Solids

The internal details of an object can be made visible by cutting the object using an imaginary plane and removing that portion of the object which is between the imaginary plane and the observer. This imaginary plane is called *cutting plane or section plane*. The surface seen on the object, while cutting it by the section plane, is called the *section*. The projection of the sectioned surface, along with the remaining portion of the object, on to the reference plane is called *sectional view*. Very often, the term section is used to mention a sectional view.

13.1 REPRESENTATION OF THE SECTION PLANE AND THE SURFACE FORMED BY CUTTING

Section plane or cutting plane is an imaginary plane used to cut the solid, so that by removing a portion of the solid the shape of the cut surface as well as the hidden details are exposed. Figure 13.1(a) shows the pictorial view of a pyramid, cut by a section plane parallel to HP. The portion between the cutting plane and the observer is assumed to be removed for the sectional view. This shows the cut surface, which is represented by section lines. Orthographic views of the pyramid are shown in Fig.13.1(b). Here the top view is the sectional view of the pyramid. It is to be noted that the front view is not affected by the section. Only the trace of the section plane is to be marked over it.

A section plane is represented by its trace, drawn in thin chain lines thickened at ends (type H lines). The direction of viewing is shown by arrows and designated by capital letters. Figure 13.2 shows the representation of the traces of section planes. When several cutting planes are joined together to bring out the section details at different angles or different offset layers, then the plane is represented by thin chain line, thickened at the ends and at the changes of direction.

The sectioned surface is indicated by a closed boundary using thick line (Type A line) and is filled with section lines. The section lines are drawn using thin line (Type B line) of equal spacing from boundary to boundary. The spacing can be 1 to 3 mm, depending on the size of the drawing. The preferred angle is 45° (towards left or right) to the reference line (see Fig. 13.3). If the major portion of the boundary of sectioned surface become almost parallel or perpendicular to the section lines, the inclination may be changed to an angle of 45° to the longitudinal axis of the sectioned surface. The section lines should be interrupted at the places of text. The process of drawing section lines is called *hatching*.

13.2 TRUE AND APPARENT SHAPES OF SECTION

If a solid is sectioned by a plane and it is projected to a plane parallel to it, the shape of the section obtained will be exactly

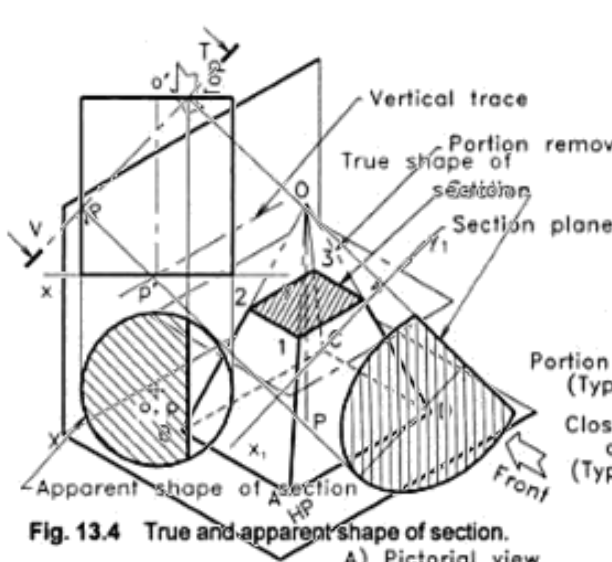

Fig. 13.4 True and apparent shape of section.

(A) Pictorial view

other side of the reference line. This gives the points for the boundary of the sectioned surface.

4. Assuming that the portion between the section plane and the observer is removed, complete the drawing of the remaining portion in the sectioned view. Draw the boundary of the sectioned surface and the view of the remaining portion by thick lines.
6. Finish the other view, in which the trace of the section plane is marked using proper line types.
7. Print the given dimensions and details.
8. Hatch the sectioned surface using Type B lines at equal spacing of 1 to 3 mm.
9. In a sectional view, if the portion of the solid removed by the section plane is to be shown, it can

(c) Several planes

Fig. 13.2 Traces of section planes.

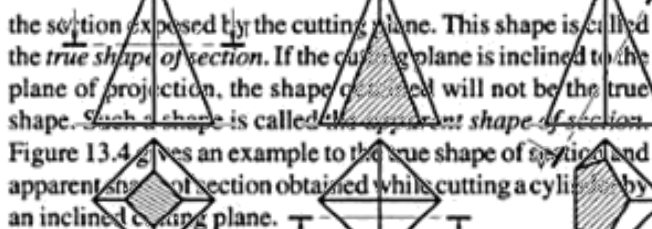

13.3 SUGGESTED PROCEDURE FOR DRAWING A SECTIONAL VIEW

Drawing of sectional views is an extension of projections of solids. Hence, the procedure explained in previous chapters is to be followed here also.

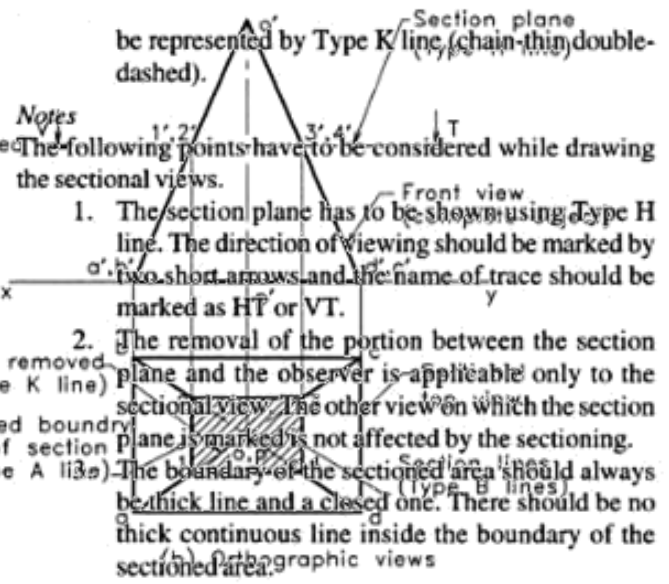

Fig. 13.5 Types of section planes and sectional views

- The following points have to be considered while drawing the sectional views.
1. The section plane has to be shown using Type H line. The direction of viewing should be marked by two short arrows and the name of trace should be marked as HT or VT.
 2. The removal of the portion between the section plane and the observer is applicable only to the sectional view. The other view on which the section plane is marked is not affected by the sectioning. The boundary of the sectioned area should always be thick line and a closed one. There should be no thick continuous line inside the boundary of the sectioned area.
 4. A flat surface cut by a plane, gives a straight boundary while a curved surface cut by a plane gives a curved boundary in the sectional view.
 5. The sectioned surface is represented by hatching lines of approximately equal spacing (1 to 3mm). Thin lines are to be drawn from boundary to boundary, preferably at large spacing and inclined at 45° to the reference line.
 6. As far as possible, the text inside a sectioned surface should be avoided. In unavoidable situations, the hatching lines are to be drawn without crossing the text.
 7. The hatching lines are to be drawn at the end of a drawing, i.e. only after finishing the drawing and printing the text.

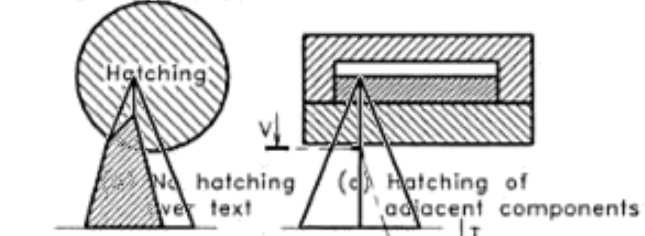

Fig. 13.3 Hatching

1. Draw the projections of the complete solid in the required position using thin lines.
2. Mark the given section plane (i.e. several cutting planes) in the given sectional views, so that the other related view can be converted into the required sectional view.
3. Then project from all the points of intersection of the section plane and the view boundaries, to the

Urheberrechtlich geschütztes Material
Urheberrechtlich geschütztes Material

If a section plane cuts a solid having flat surfaces, the number of straight edges formed by cutting is = the number of points of intersection = the number of surfaces cut. Also the figure will be a closed one.

13.4 CLASSIFICATION OF SECTION PLANES

A section plane is considered as an imaginary plane perpendicular to one of the reference planes. Hence, the projection of the section plane to which it is perpendicular will be a line representing its trace. Figure 13.5 gives the example for five different types of section planes and the sectional views obtained by cutting a square pyramid.

The classification of the section planes are:

1. Section plane parallel to HP.
2. Section plane parallel to VP.
3. Section plane inclined to HP.
4. Section plane inclined to VP.
5. Combination of several section planes.

13.5 SECTION PLANE PARALLEL TO HP

A section plane parallel to HP and perpendicular to VP gives a sectional top view. As the section plane is parallel to HP, the projection of the section on the HP is of true shape and size. Figure 13.6 gives an example for sectioning a prism lying on HP by a cutting plane parallel to HP.

Example 13.1

A right regular pentagonal prism, side of base 32 mm and height 60 mm, is lying on one of its rectangular faces upon HP, keeping the axis perpendicular to VP. A section plane

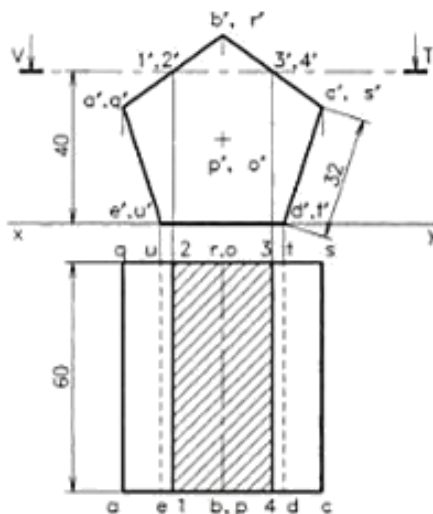

Fig. 13.6 Sectional top view of a prism (section plane parallel to HP).

parallel to HP cuts the solid at a height of 40 mm above the resting surface. Draw the front and sectional top views of the prism.

Refer to Fig. 13.6.

1. Draw the front and top views of the pentagonal prism using thin lines and name the corners.
2. Name the trace VT of the cutting plane at the given height above the xy -line in the front view.
3. Name the points of intersection of the cutting plane with the surfaces one by one in the clockwise direction, as 1', 2', 3', and 4', since the plane cuts four surfaces.
4. Draw projectors from these points to get the corresponding points in the top view. Join 1,2,3, and 4 by thick lines to get the cut surface.
5. Convert the thin lines to the proper line types and print the given dimensions. Hatch the cut surface formed by points 1, 2, 3 and 4 using thin lines (Type B line), drawn at 45° to the xy line.

13.6 SECTION PLANE PARALLEL TO VP

The method of taking sectional view of a solid by a cutting plane parallel to VP is similar to that when it is parallel to HP. Since the section plane is parallel to VP, the sectional view obtained on VP will be of the true shape and size.

Example 13.2

A right regular triangular pyramid, edge of base 60 mm and height 70 mm, is resting on HP on its base with one edge of its base parallel to and closer to VP. A cutting plane, parallel to and passing through a point 16 mm in front of the top view of the axis, cuts the solid. Draw the sectional front view of the pyramid.

Refer to Fig. 13.7.

1. Draw the top and front views of the pyramid in the given position using thin lines and name the corners.
2. Mark the HT of the section plane on the top view and locate the intersection points 1, 2, and 3 on the three surfaces of the pyramid.
3. Project from 1 and 3 to the front view and mark the points 1' and 3' on the base edges. The point 2' lies on a vertical line in the front view, so the projector from point 2 will not intersect but coincide the true length line $o'c'$. In a similar situation, construct the true length line $o'c_1'$ by rotating the top view of the edge oc to oc_1 position and projecting upwards as shown in figure. Then the distance from o to 2 is

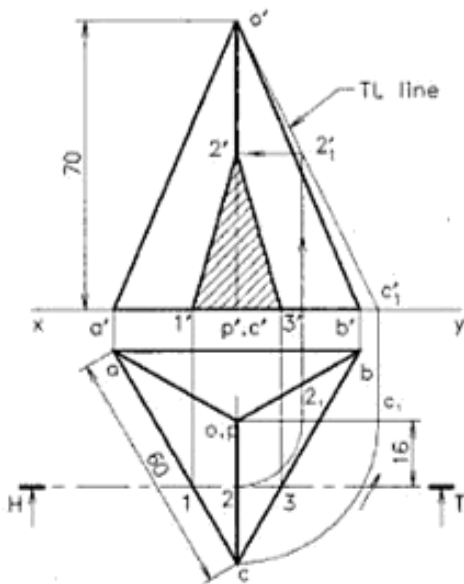

Fig. 13.7 Sectional front view.

transferred to the true length line by drawing an arc and a projector to get the point $2'$ on it. A horizontal line drawn through that point intersects the edge $o'c'$ giving the point $2'$. Join $1'$, $2'$, and $3'$ by thick lines to get the boundary of the section.

4. Finish the top and front views, print the given dimensions and hatch the sectioned surface to complete the drawing.

13.7 SECTION PLANE INCLINED TO HP

If the cutting plane is inclined to HP and perpendicular to VP, the top view gives the section of the solid.

Example 13.7

A square pyramid of side 50 mm and height 70 mm is kept on HP so that the sides are equally inclined to VP. A cutting plane perpendicular to VP, but inclined 60° to HP cuts and removes the apex portion so that the plane passes through the mid-point of the axis in the front view. Draw front view, sectional top view and the true shape of section.

Refer to Fig. 13.8.

1. Draw the top and front views of the pyramid keeping the square base 45° inclined to VP.
2. Mark the section plane VT in the front view so that it makes 60° to the xy line and passing through the mid point of the axis.

3. Name the points of intersection of cutting plane with edges as $1'$, $2'$, ... $5'$ in order to get a sectional top view marked clockwise. Here, five surfaces are cut hence, five points of intersection are obtained.
4. Project from points $1'$, $2'$, ... $5'$ to the top view and mark the same at the intersection points on the corresponding edges. Join these points by straight lines to get the apparent shape of section.
5. The apparent shape of the section is symmetrical about the line jk drawn through $o'p'$, parallel to xy line. To get the true shape of section, draw a line of symmetry j_1k_1 at any position parallel to the section plane VT and draw projectors from points $1'$, $2'$, $3'$, ... etc., perpendicular to the line j_1k_1 as shown in figure. Measure the distances of points 1, 2, ... 5 from jk line, in the top view and mark them symmetrically along corresponding projectors on both sides about the line j_1k_1 . Join the points by straight lines, to get the true shape of section.
6. Finish the views, enter the given dimensions and hatch the apparent as well as the true shape of section by drawing section lines at 45° inclination to the line of symmetry.

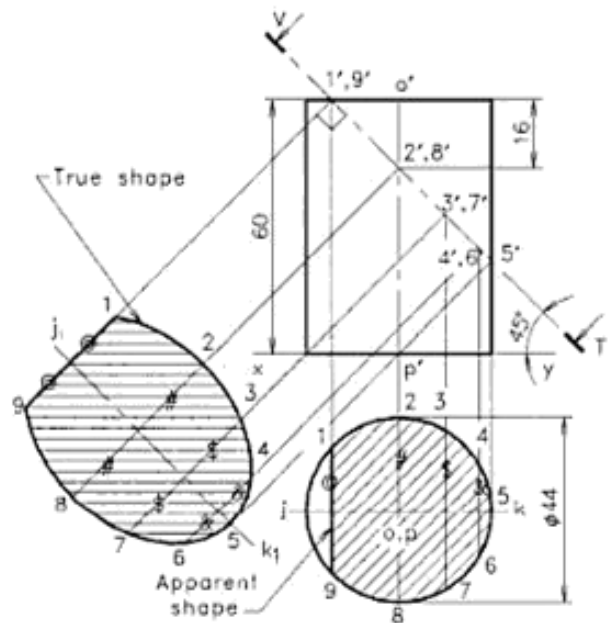

Fig. 13.8 Sectional top view (section plane inclined to HP).

EXERCISES

(# Problem similar to the worked-out examples)

1. A right regular pentagonal prism, side of base 30 mm and height 66 mm, is lying on one of its rectangular faces upon HP, keeping the axis perpendicular to VP. A section plane parallel to HP cuts the solid at a height of 34 mm above the resting surface. Draw the front and sectional top views of the prism. #
2. A pentagonal pyramid, side of base 32 mm and height 65 mm, is resting on HP keeping the axis vertical and an edge of base perpendicular to VP. A horizontal cutting plane cuts the solid at a height of 25 mm from the base. Draw front and sectional top view of the pyramid. #
3. A right regular square pyramid, side of base 55 mm and height 66 mm, lies on one of its triangular faces upon ground such that its axis is parallel to VP. A section plane parallel to HP cuts the axis at its midpoint. Draw its front view and sectional top view. #
4. A pentagonal pyramid, side of base 35 mm and height 66 mm, lies on one of its triangular faces upon ground such that its axis is parallel to VP. A section plane parallel to HP cuts the axis at its midpoint. Draw its front view and sectional top view. #
5. A square pyramid, edge of base 50 mm and height 70 mm, is resting upon HP on its base, keeping the base edges equally inclined to VP. A cutting plane, parallel to VP and passing through a point located 10 mm in front of the top view of the axis, cuts the solid. Draw the sectional front view of the pyramid. #
6. A hexagonal pyramid of 32 mm side and height 66 mm rests on HP keeping one of its base edges parallel to VP. A cutting plane parallel to VP cuts the solid 12 mm in front of the vertical axis. Draw sectional front view and top view of the pyramid. #
7. A pentagonal pyramid of side 36 mm and height 80 mm is kept on HP so that one side is perpendicular to VP. A cutting plane perpendicular to VP, but inclined 65° to HP cuts and removes the apex portion so that the plane passes through the mid point of the axis in the front view. Draw front view, sectional top view and the true shape of section. #
8. A cylinder is resting on its base upon HP. It is cut by a plane inclined at 60° to HP, cutting the axis at a point 20 mm from the top. If the diameter of the cylinder is 50 mm and length is 70 mm, draw the projections of the sectioned cylinder and the true shape of section. #
9. A hexagonal pyramid, base 32 mm side and axis 70 mm long, is lying on one of its triangular faces on the ground with the axis parallel to VP. A vertical section plane, whose HT passes through the mid point of the axis of pyramid in the given position, makes an angle of 25° with the reference line and cuts the pyramid removing a portion of the base. Draw the top view, sectional front view and the true shape of section.

Urheberrechtlich geschütztes Material

Development of Surfaces

The process of opening out all the surfaces of a three-dimensional body onto a flat plane is called *development of surfaces* and the resulting shape is called the *pattern*. The surface so laid out is termed as its *development*. The process of development consists of drawing successive surfaces of the object and every line on the development should have the true length.

15.1 THE PRINCIPLE OF DEVELOPMENT OF SURFACES

The surfaces of most solids which are used in engineering design work can however be opened out into a flat plane by the process of development. The setting out of a pattern forms the basis for the manufacture of fabricated sheet metal

or plate components. After the development has been cut out, it is bent or rolled into the required shape. The objects produced by development and fabrication include pipes, ducts, pans, bins, buckets, tanks, etc.

The development of surfaces of the most common solids is shown in the Fig. 15.1. The patterns of prism and pyramid are nearly the side and end faces unfolded into a plane surface, while the patterns for cylinder and cone are simply the curved surfaces and ends rolled or unfolded into a plane surface. It may be noted that the development of a surface is usually drawn showing the inside pattern and the true length dimensions are marked on it accordingly.

The solids bound by plane surfaces are polyhedra. Their development can be obtained by turning the object so as to unroll the imaginary enclosing surface upon a plane. Since

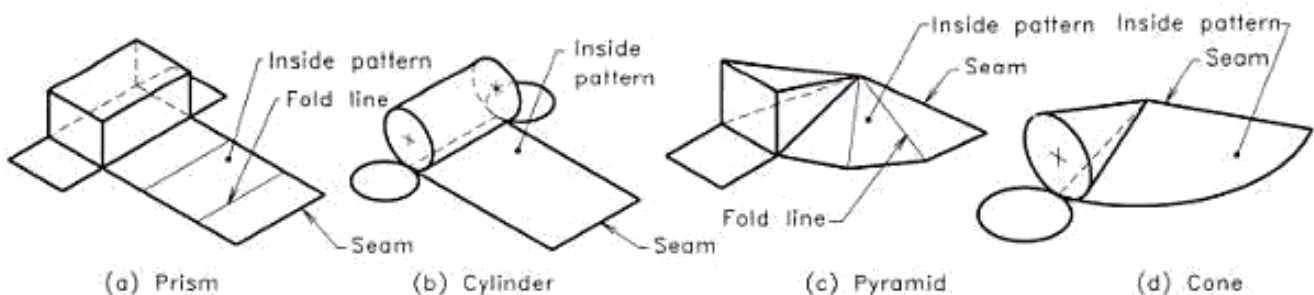

Fig. 15.1 Development of surfaces of solids.

cones and cylinders are solids bound by curved surfaces, their developments can be obtained easily by unrolling the imaginary enclosing surface upon a plane. Solids bound by double curved surfaces or wrapped surfaces are spheres, paraboloid, etc. Their development cannot be obtained by just unrolling them. A double curved surface is a surface generated by revolving a curved edge about a straight line.

To make objects using sheet metal, paper cardboard, etc. allowances for the lap and seams are to be added to the inside pattern, obtained by the development. Here, for avoiding confusion in the beginning, that part is not included in the worked-out examples. Any how, students are advised to make models of the solids after drawing the patterns with sufficient overlaps for cut and paste. This will help to understand the shapes of various solids, and their developments clearly.

15.2 METHODS FOR DRAWING THE DEVELOPMENT OF SURFACES

The following are the principal methods used for development of surfaces.

1. **Parallel line development:** This method is used when the surfaces of the solid are generated by a line which moves parallel to the axis of the solid. Development of prisms and cylinders can be drawn by this method i.e. by drawing *stretch out line* or *girth line*. Stretch out line gives the perimeter of the object.
2. **Radial line development:** This method is used when

the surfaces of the solid are generated by a line, one end of which remains stationary while the other end traces out any path. Pyramids and cones can be drawn by this method.

3. **Triangulation development:** This method is used when the surfaces of the solid can be imagined to consist of a number of triangles. Transition pieces are developed using this method.
4. **Approximate development:** This method is used in the development of surfaces of solids bound by double curved surfaces. Development of a sphere is obtained by using this method.

Figure 15.2 shows general form of the four methods of developing surfaces. The development of surfaces may also be grouped according to the shape of the solid as polyhedra, cylinder, cone, truncated solids, intersecting solids, transition pieces, objects, spheres, etc.

Notes:

1. Development of a surface is drawn using the true lengths only.
2. The inside pattern is drawn as a development, so that by folding or rolling it the shape of the surface is obtained.
3. Usually the development is prepared by referring the front view.
4. The outline of the developed surface is represented by thick lines and the folding by thin lines.
5. Usually capital letters are used to name the corners of the development.

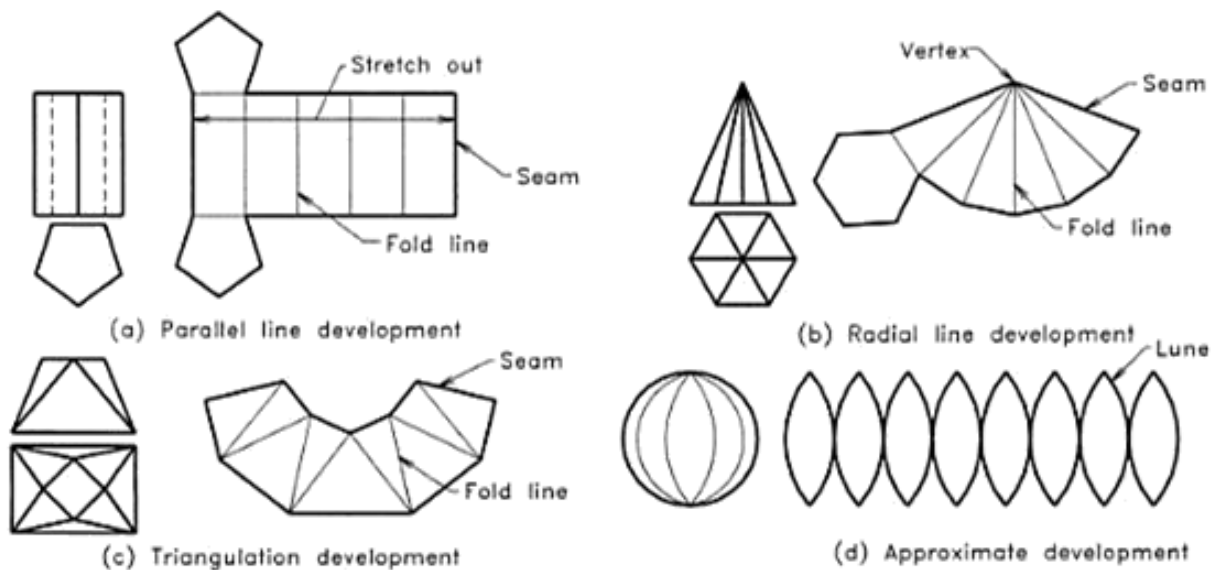

Fig. 15.2 Methods of development of surfaces.

Urheberrechtlich geschütztes Material

6. Parallel line method is used to develop solids having uniform cross-section about its axis.
7. Radial line method is used to develop solids having uniformly varying cross-section along the axis.
8. Triangulation method is applied for transition pieces which are having a single curved surface.
9. For double curved surfaces like spheres, only approximate development can be obtained.

15.3 DEVELOPMENT OF POLYHEDRA

Development of prisms, pyramids and platonic solids can be done using either parallel line development or radial line development method. Figure 15.3(a) shows the complete development of various prisms using parallel line development method. Radial line development method is used for developing pyramids. The varieties are shown in Figure 15.3(b). For platonic solids, the cube may be treated as a prism. Tetrahedron and octahedron may be developed by drawing the triangular faces with one touching to the other. Figure 15.3(c) shows the development of platonic solids. The following examples explain the step by step procedure to develop polyhedra.

Example 15.1

Draw the development of the surface of a rectangular prism, base $24 \text{ mm} \times 30 \text{ mm}$ sides and axis 40 mm long, having a longer edge of the base parallel to VP.

Refer to Fig. 15.4.

1. Draw the top and front views of the prism. Locate the left corner of the top view as the seam (joint) and name the corners clockwise from this corner.
2. Draw the stretch out lines 5 to 5 and 1 to 1 as shown in figure. Mark the lines 5-6 and 7-8 of length 24 mm , and 6-7 and 8-5 of length 30 mm to represent the true lengths of sides at the base. Mark the verticals 5-1, 6-2, etc. of length 40 mm to represent the true height of the edges and the fold lines. Also draw the two rectangles 5,6,7,8 and 1,2,3,4 to represent the true size of the base and top of the rectangular prism.
3. Convert the outline of the development to thick line and keep the foldings as thin line. Print the given dimensions on both the projections as well as on the development.

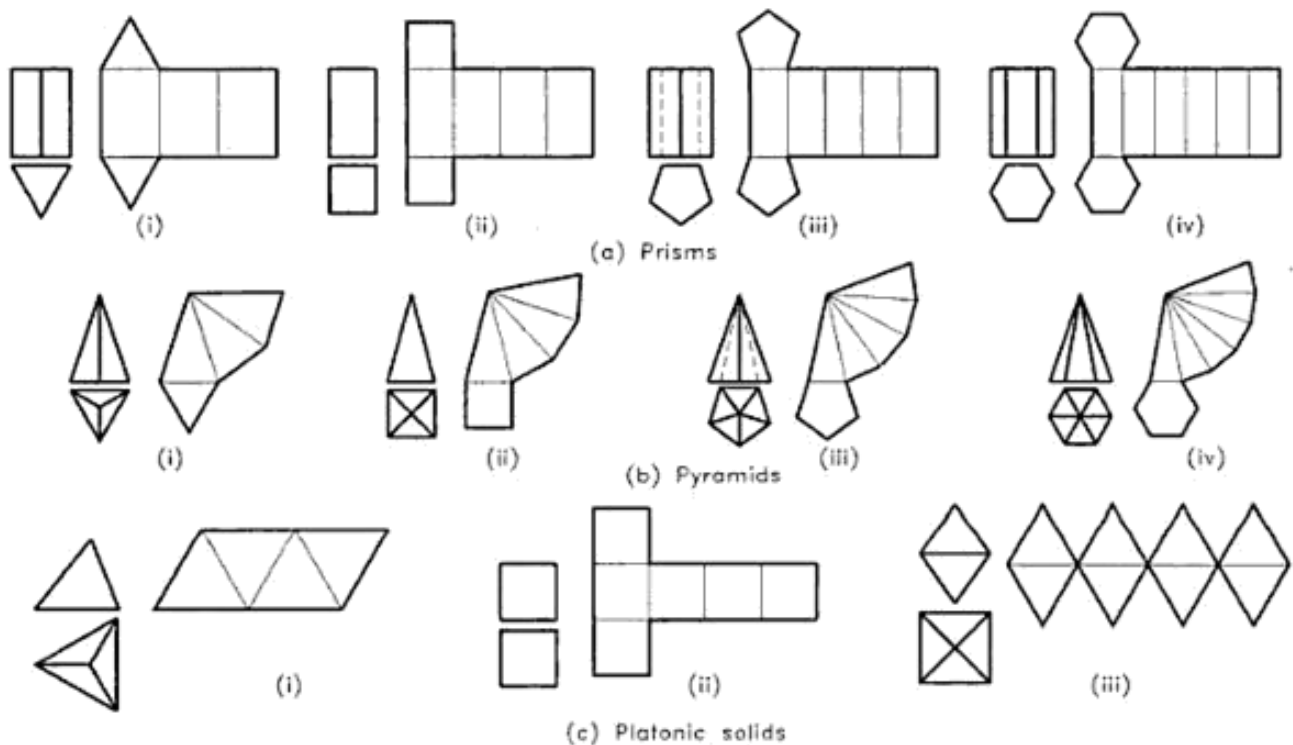

Fig. 15.3 Development of polyhedra.

Urheberrechtlich geschütztes Material

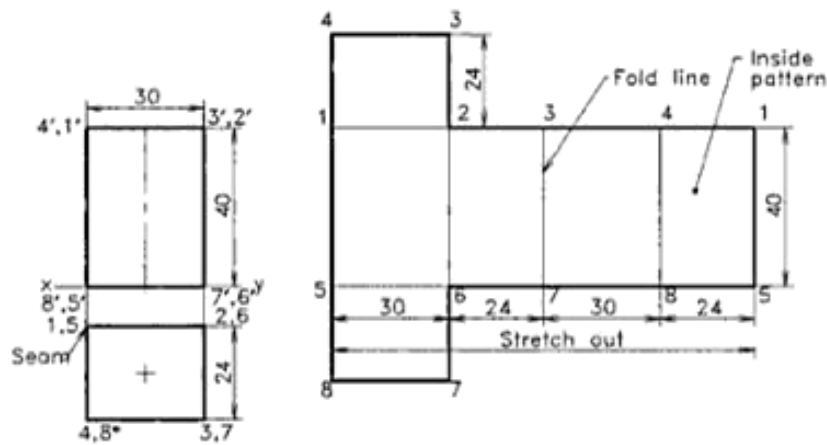

Fig. 15.4 Development of a rectangular prism.

Example 15.2

Develop the full size pattern of a right regular pentagonal pyramid, base 24 mm and height 50 mm.

Refer to Fig. 15.5.

1. Draw the top and front views of the pentagonal pyramid keeping one sloping edge parallel to VP in order to get the true length (TL) directly from the front view. Locate oa as the seam (joint) of the development on left side and name the corners clockwise starting from this corner.
2. Measure the true length (TL) of the sloping edge from the elevation and use it to draw the lateral surface of the pyramid as shown in figure. An arc with radius equal to TL may be drawn first. Then mark the true length of the base edge of the pyramid on the arc.

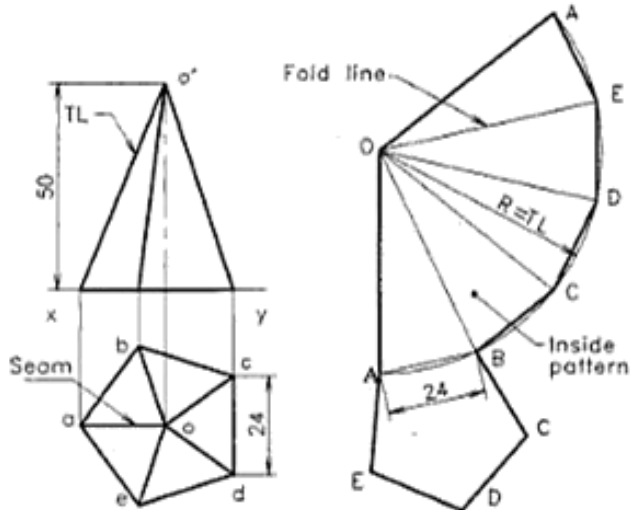

Fig. 15.5 Development of a pyramid.

3. Add a pentagon of true size to one of the base lines, preferably to the first edge.
4. Finish the drawing, thicken the outline and print the given dimensions to complete.

Example 15.3

Draw the development of the lateral surface of a right regular hexagonal prism of 24 mm base edge and 56 mm height. An ant moves on its surface from a corner on the base to the diametrically opposite corner on the top face, by the shortest route along the front side. Sketch the path in the elevation.

Refer to Fig. 15.6.

1. Draw the top and front views of the hexagonal prism. Locate corner a as the seam (joint) of the development on left side and name the corners clockwise starting from this corner.
2. Draw the stretch out line AA of length 6×24 mm and complete the development of the prism as shown in figure.
3. Assume that the ant moves from a' to d' in the elevation along the front side. Join AD in the developed surface, which is the shortest distance between A and D . This line cuts the fold lines E and F at N and M respectively. Draw horizontals to cut the respective edges at n' and m' in the elevation. Join a', n', m' and d' to represent the shortest path along front side in the elevation.
4. The ant can also have the shortest path along the rear side of the prism. This has to be shown in short dashes.
5. Finish the views using proper line types and print the given dimensions to complete the drawing.

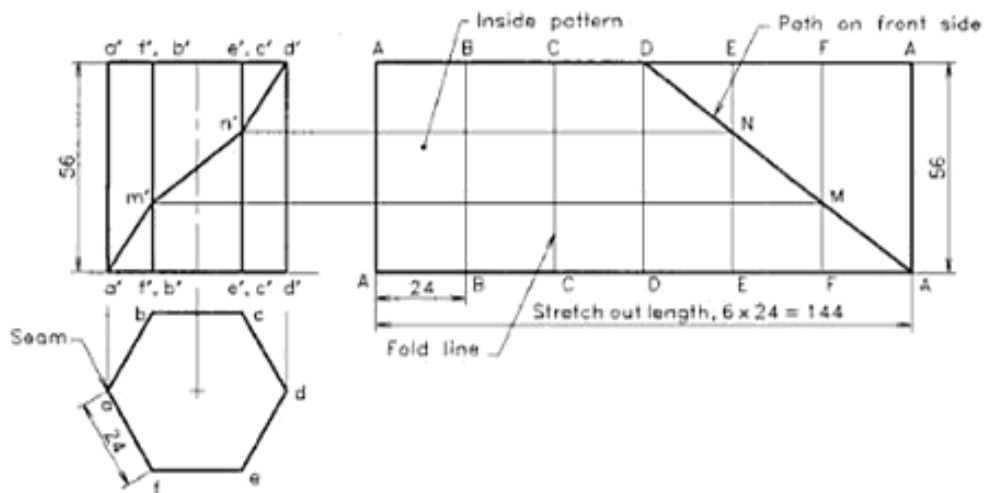

Fig. 15.6 Lateral surface of a prism.

15.4 DEVELOPMENT OF CYLINDER AND CONE

Development of the lateral surface of a cylinder is a rectangle having width equal to length of the cylinder and the stretchout length = $p \times$ diameter of the base. For showing details on the lateral surface, the cylinder may be assumed as a prism having 12 sides (generators).

Development of the lateral surface of a cone is a sector of a circle having radius equal to the length of the generator (slant height of the cone). The angle at the centre of the sector depends on the circumference of the base of the cone and the length of generator.

$$\text{The sector angle } \theta = 360 \times r/R$$

where

r = radius of base circle and

R = slant height (generator) of cone (TL)

For showing details on the lateral surface, the cone may be assumed as a pyramid having 12 number of sides. Parallel line development is applicable to the development of cylinders while radial line development is used for the development of cones.

Example 15.4

A right circular vertical cylinder of 44 mm diameter and height 60 mm rotates uniformly. A plotter pen-tip moves vertically at uniform speed on the surface of the cylinder from the bottom to the top, so it moves 60 mm while the cylinder completes one rotation. Draw the line marked on the cylinder in the front view and measure the true length of it.

Refer to Fig. 15.7.

1. Draw the top and front views of the cylinder.
2. Draw the development of the cylinder after marking the stretch out length = $\pi \times 44$.

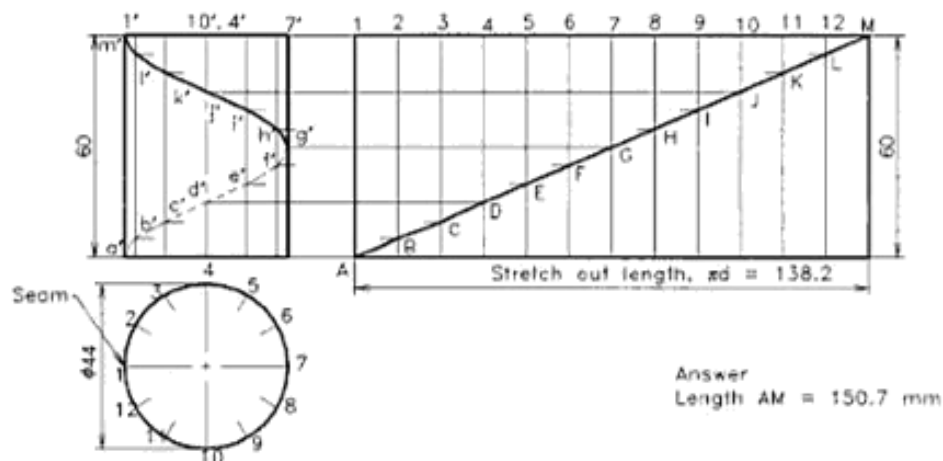

Fig. 15.7 Lateral surface of a cylinder.

- As the plotter pen moves axially, the cylinder rotates once, marking a helix on the surface of the cylinder in the front view. To draw the helix, divide the base circle of the top view into 12 parts radially and the stretch out length into the same number of divisions. Locate the seam (joint) of the development on left side and name the 12 generators clockwise starting from this point.
- The helix seen in the front view is the diagonal to the rectangular pattern. Hence, draw the diagonal AM and mark the intermediate points. Mark the 12 generators on the front view and draw horizontal lines from A, B, C, D, ..., M to get a', b', c', \dots, m' on these generators, which forms the helix.
- Join the points a', b', c', \dots, m' by a smooth curve of thick line for the visible portion and short dashes for the hidden portion of the helix. Also measure the length AM and print it against the answer.

Example 15.5

A right circular cone has 50 mm diameter and 50 mm height. Draw the complete development of the cone showing the twelve generators.

Refer to Fig. 15.8.

- Draw the top and front views of the cone and mark the 12 generators on them. Locate the seam (joint) on the left side of top view and name the generators clockwise starting from this point. Also measure the generator length, TL.
- To draw the development of the cone, calculate the

sector angle $\theta = 360 \times R/TL = 161^\circ$, where R is the radius of the cone. Draw an arc with radius = TL to get the sector of angle θ , which forms the development of the lateral surface of cone.

- To mark the 12 generators on the sector, divide the angle θ into half by drawing the angular bisector O-7 using a compass. Similarly, redivide them by drawing lines O-4 and O-10 as shown using compass. Further divide the 1/4th sector into three equal parts by trial and error method using a bow divider. For this take 1/12th of the circumference of the base circle on the bow divider and mark it along the circular portion of the sector successively. If the third leg is not coinciding with the end point of the arc, adjust 1/3rd of this difference on the divider and repeat the same from the beginning. By one or two trials the required divisions are obtained with reasonable accuracy.
- Draw radial lines from O to the divisions to represent the 12 generators and name them. Add a circle of base diameter of cone to any one (say to the 7th) of the generators and divide that also into 12 parts radially.
- Finish the views using proper line types and print the given dimensions to complete the drawing.

Example 15.6

Draw the development of a right circular cone of base diameter 60 mm and height 64 mm resting upon HP on its base. An insect moves from a point on the base edge to the

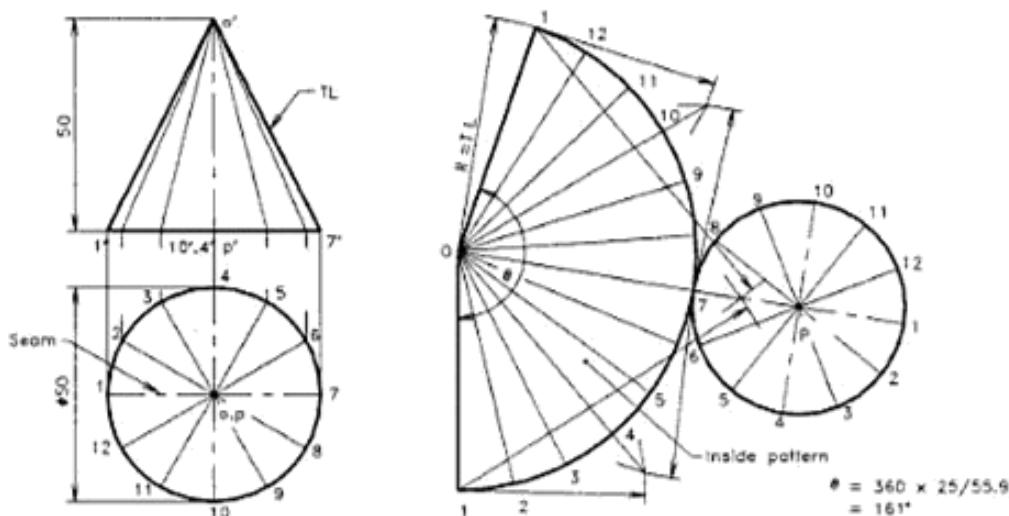

Fig. 15.8 Complete development of a cone showing the twelve generators.

Urheberrechtlich geschütztes Material

diametrically opposite point on the same edge through a shortest path along the curved surface on front side. Mark the shortest path in the front and top views of the cone.

Refer to Fig. 15.9.

1. Draw the top and front views of the cone and mark the 12 generators on them. Locate the seam (joint) on the left side of top view and name the generators clockwise starting from this point. Also measure the generator length, TL.
2. To draw the development of the cone, calculate the sector angle $\theta = 360 \times R/TL = 152.5^\circ$
Draw an arc with radius = TL to get the sector of angle θ and complete the development of the cone.
3. To find the path of the insect, divide the sector radially into 12 as explained in example 15.5 and name them.
4. Let the shortest path of the insect be from 7 to 1, along the curved surface on front side. In the pattern, draw a straight line AG from point 7 to 1, crossing the generators at B, C, D, etc. to represent the shortest path. Measure the radial distance OB, OC, OD, etc. and mark as $o'b''$, $o'd''$, etc. on the true length line TL in the front view. Here, TL is the outermost generator of the cone. Draw horizontal lines from b'' , c'' and d'' to intersect their respective generators. Join the points a' , b' , c' , etc., by a

smooth curve to obtain the shortest path in the front view.

5. Project vertically downwards from the points a' , b' , c' etc. to get the corresponding points on the generators drawn in the top view as a , b , c , etc. Join the points by a smooth curve to get the top view of the shortest path.
6. Finish the views using proper line types and print the given dimensions to complete the drawing.

15.5 DEVELOPMENT OF TRUNCATED SOLIDS

If a solid is cut by a plane inclined to its base, the portion obtained after removing the top is a truncated solid. If solids with uniform cross-section are truncated, their development can be obtained by parallel line development method. If the solids are of uniformly varying cross-section, the development of sectioned solids of that group are drawn using radial line development method. In both cases, the projections of the complete solids are drawn first and the section plane is marked. The true lengths of the intermediate points formed by cutting are measured from the two views and marked them on the foldings or generators to get the final shape of the development.

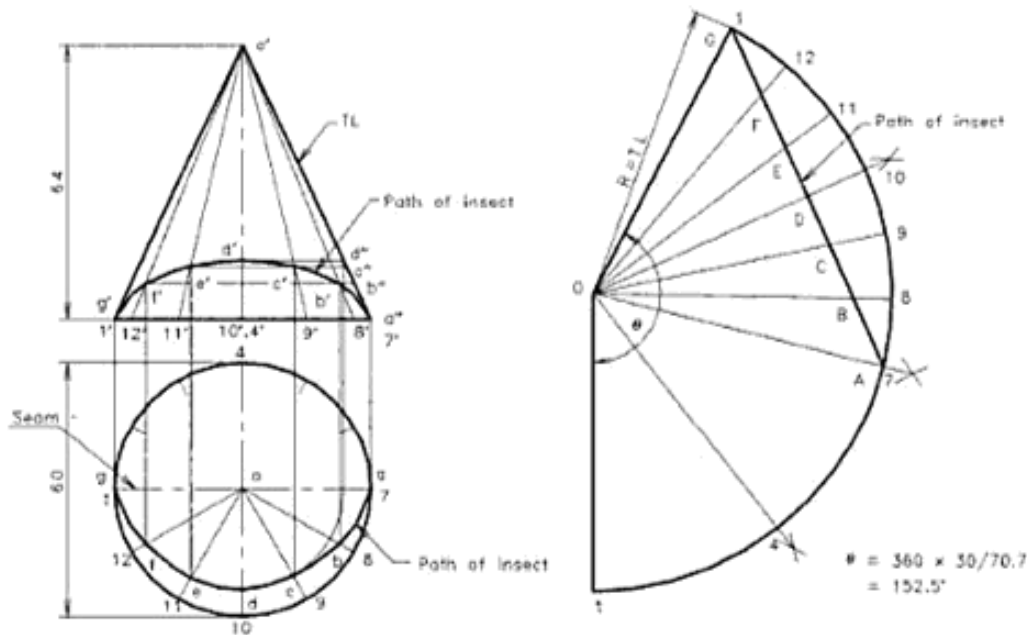

Fig. 15.9 Lateral surface of a cone.

Urheberrechtlich geschütztes Material

Example 15.7

A right regular hexagonal prism of base edge 20 mm and height 50 mm rests on its base with one of its base edges perpendicular to VP. A section plane inclined 45° to HP cuts its axis at its middle. Draw the complete development of the truncated prism including the sectioned surface.

Refer to Fig. 15.10.

1. Draw the top front views of the prism in the position given. Mark the section plane at an angle of 45° to HP, cutting the axis at the middle. Also locate the seam at the left corner of the top view and name the corners clockwise.
2. Draw the stretch-out line 1-1 of length 6×20 mm and mark the fold lines 1, 2, 3, etc. on it. The section plane cuts the six edges of prism, so mark these six points as p', q', r', s', t', u' on the front view. Then get the true shape of sectioned surface.
3. Draw a horizontal lines from points p', q', r', s', t' and u' to intersect the fold lines at P, Q, R, S, T, and U, respectively. Join the points by straight lines to obtain the development of the lateral surface. Add a hexagon of true size of base to the first fold in order to complete the full development.
4. Finish the views using proper line types and print the given dimensions to complete the drawing.

Example 15.8

A right regular pentagonal pyramid, side of base, 36 mm and height 64 mm, rests on its base upon the ground with one of its

base sides parallel to VP. A section plane perpendicular to VP and inclined at 30° to HP cuts the pyramid, bisecting its axis. Draw the development of the truncated pyramid.

Refer to Fig. 15.11.

1. Draw the top and front views of the pyramid and mark the section plane at 30° on the front view. Also locate the seam at the left corner of the top view and name the corners clockwise.
2. To draw the development of the pyramid, get the true length line of the sloping edge as $o'u'$ in the front view by rotating the line O_3 , as shown in the figure. With radius equal to the true length of sloping edge (TL) draw an arc, mark the five sides on it and complete the development of lateral surface of the pyramid.
3. To mark the points P, Q, R, S, T on the development, the true distances of these points from the apex O have to be determined. For this, draw horizontal lines from p', q', r', s' and t' to the true length line $o'u'$ and get the points p'', q'', r'', s'' and t'' . Then the distances $o'p'', o'q'',$ etc. are marked as OP, OQ, etc. on the corresponding sloping edges, to get the points PQRS and T on the development. Join them by straight lines to get the final form of the lateral surface of the truncated pyramid.
4. Finish the views using proper line types and print the given dimensions to complete the drawing.

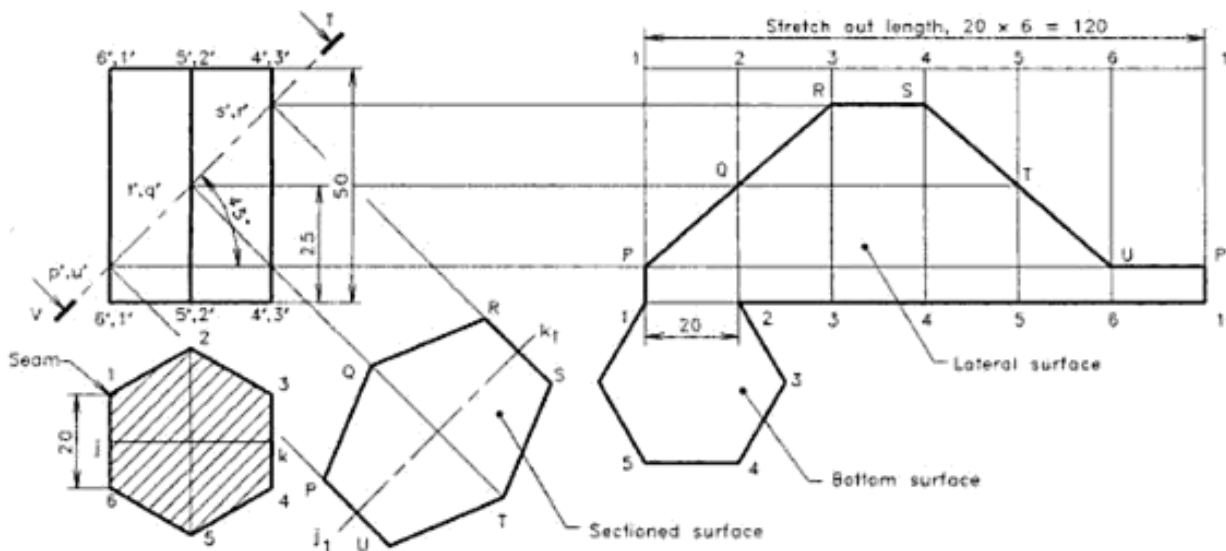
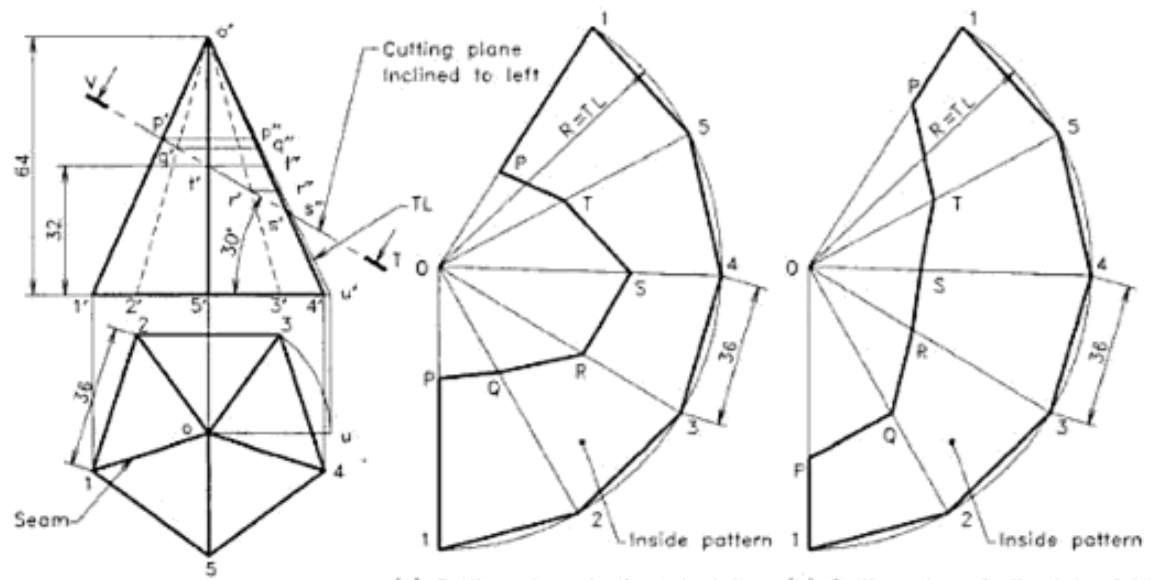

Fig. 15.10 Complete development of a truncated prism.

Urheberrechtlich geschütztes Material



(a) Cutting plane inclined to left (b) Cutting plane inclined to right

Fig. 15.11 Lateral surface of a truncated pyramid.

Example 15.9

Draw the development of the lateral surface of the truncated right circular cylinder of diameter 44 mm and height 70 mm. The tube is placed on HP. A section plane, passing through the geometrical centre of the top face of the tube, perpendicular to VP and inclined at 45° to HP, cuts off the top portion of the tube. A similar sectional plane making an angle of 30° to HP in the opposite direction, cuts the axis at a height of 14 mm from the base.

Refer to Fig. 15.12.

1. Draw the top and front views of the cylinder and mark the section planes.
2. Divide the base circle into 12 equal parts. Draw vertical projectors through the 12 points and obtain the corresponding points in the front view. Also locate the seam at the left side of the top view and name the generators clockwise.
3. Draw the stretch out line and mark the 12 generators on it. Point A on the development is the point of

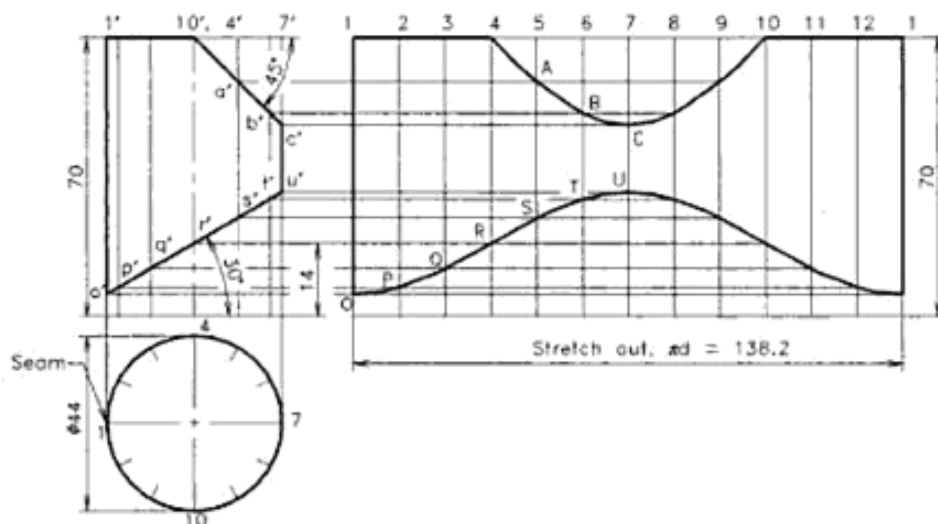

Fig. 15.12 Lateral surface of a truncated cylinder.

Urheberrechtlich geschütztes Material

intersection of the horizontal line through a' and the vertical line through point 5. Similarly, obtain the other points B, C, D and E and points P, Q, R, S, T, etc. as shown in the figure. Complete the development by drawing smooth curves through these points.

4. Finish the views using proper line types and print the given dimensions to complete the drawing.

Example 15.10

A right circular cone, 70 mm base and 70 mm height, rests on its base on the ground plane. A section plane perpendicular to VP and inclined at 30° to HP cuts the cone, bisecting its axis. Draw the development of the lateral surface of the cone.

Refer to Fig. 15.13.

1. Draw the top and front views of the cone and mark the section plane at an angle of 30° to HP.
2. Measure the true length TL of the outermost generator and calculate the sector angle,

$$\theta = 360 \cdot R/TL = 161^\circ$$

Using TL and θ , draw the sector to get the development of the cone.

3. Divide the top view into 12 equal divisions and

draw the corresponding generators in the front view as well as in the pattern as explained in Example 15.5. Also locate the seam at the left side of the top view and name the generators clockwise.

4. Let the sectional plane cut the generators in the front view at points $a', b', c',$ etc. Draw horizontal lines from these points to get their true lengths. Mark $OA = o'a''$, $OB = o'b''$ and so on in the pattern to get the points A, B, C, etc. on generators 1, 2, 3, etc. Join the points A, B, C, etc. to get the first half of the curve. Since the section is symmetrical about the generator O_7 , copy the first half of the curve to the remaining portion as a mirror image by drawing arcs. This completes the drawing of the lateral surface of the truncated cone as shown in Fig. 15.13(b).
5. If the direction of inclination of cutting plane is changed, the development of the cone is seen as in Fig. 15.13(c). Note that both developments are the same and only the seam is different relative to the direction of inclination.
6. Finish the views using proper line types and print the given dimensions to complete the drawing.

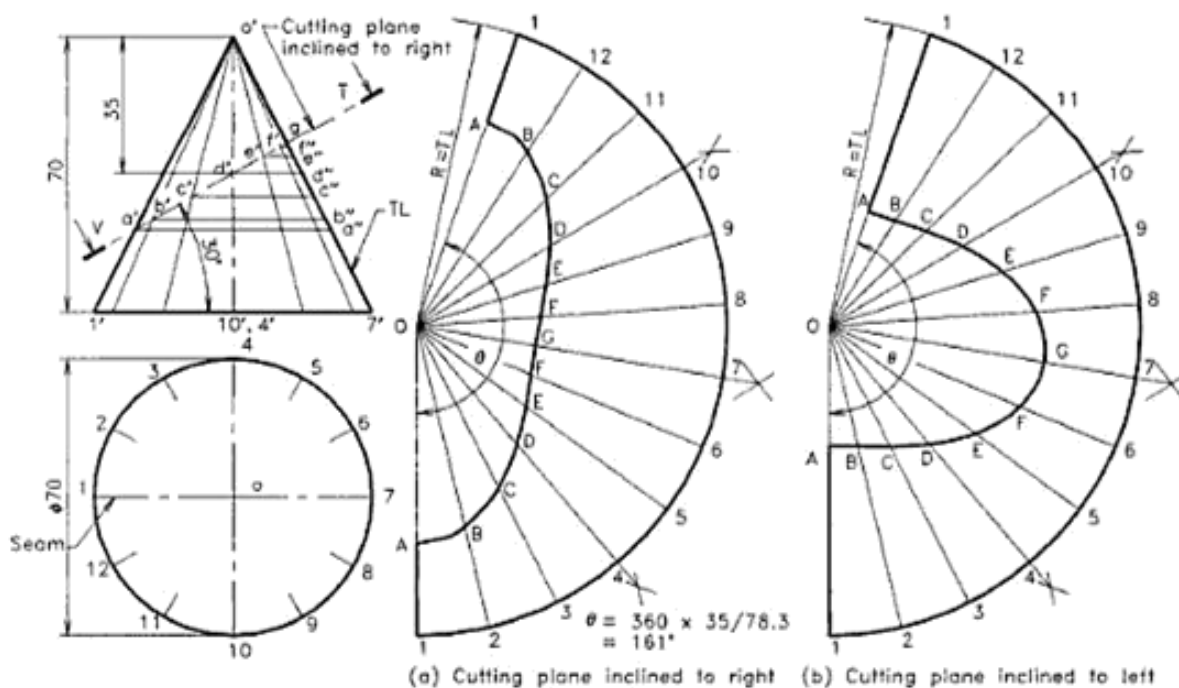

Fig. 15.13 Lateral surface of a truncated cone.

15.6 DEVELOPMENT OF SOLIDS HAVING HOLE OR CUT

The development of the lateral surface of solids having holes or cut, can be drawn by following the methods explained for truncated solids. The orthographic views and development of the lateral surface of the full solid are drawn first. The hole or cutting is marked in the front view showing the true shape, and sufficient number of generators are drawn over it in order to get points of intersection. Then these points of intersection are transferred to the pattern, after finding the true lengths either by following the parallel development method or radial line development method, which ever is applicable.

Example 15.11

A square prism of 40 mm side length and 60 mm height rests on its base upon HP, such that the vertical faces are equally inclined to VP. A horizontal hole, 40 mm diameter is drilled through the geometrical centre of the prism with the axis perpendicular to VP. Develop the lateral surface of the prism.

Refer to Fig. 15.14.

1. Draw the top and front views of the prism in the given position and draw a circle of diameter 40 mm at the centre of the axis to represent the hole.
2. Draw the development of the lateral surface of the prism. Also locate the seam at the left side of the top view.
3. Divide the circular hole in the front view radially into 12 divisions and transfer the points of intersection $1'$, $2'$, and $3'$, to the top view as shown.

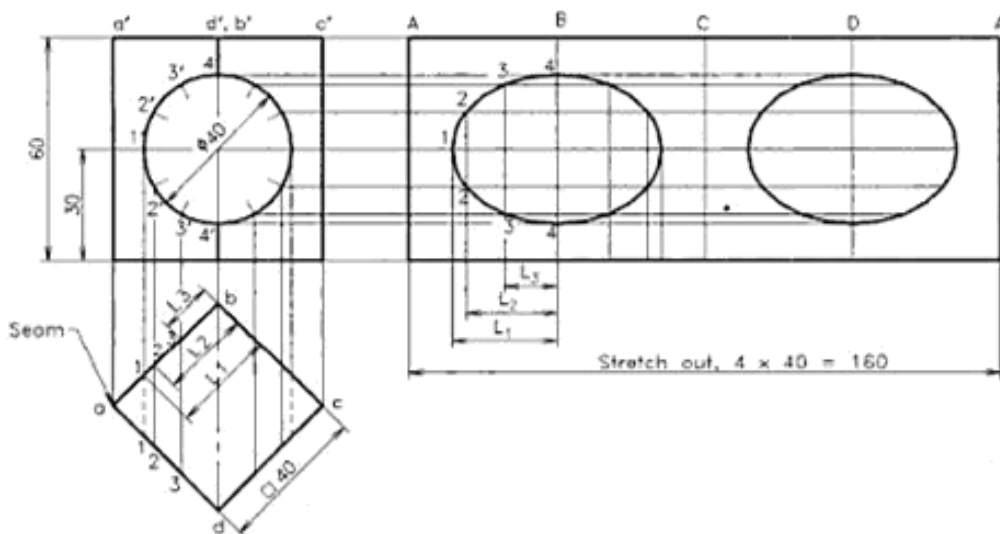

Fig. 15.14 Lateral surface of a prism with a hole.

The true distance of point $1'$ from the edge b' is the distance of point $1'$ from edge b in the top view. Let this true distance = L_1 . Similarly, the true distances of points 2 and 3 can be marked as L_2 , L_3 in the top view.

4. To draw the development of the hole, insert horizontal lines through points $1'$, $2'$, $3'$ and $4'$ towards the pattern. Mark L_1 , L_2 , and L_3 , the true distances along these lines from fold line B to get the points 1, 2, and 3 on the left side of the line B. Take a mirror image of these points on right side of the line B and join them by a smooth curve to get the ellipse as shown.
5. Repeat the same about the fold line D also to get the second ellipse on the development.
6. Finish the views using proper line types and print the given dimensions to complete the drawing.

Example 15.12

A vertical cylinder of diameter 60 mm has a central horizontal square through hole of side 40 mm. The centre of the hole is coinciding with the centre of the axis of cylinder and the sides are equally inclined to HP. Draw development of the lateral surface of the cylinder with hole.

Refer to Fig. 15.15.

1. Draw the top and front views of the cylinder in the given position and construct the square hole. For this draw a line $l'm'n'$ of length 40 mm at an angle of 45° , keeping the mid point m' at the middle of the

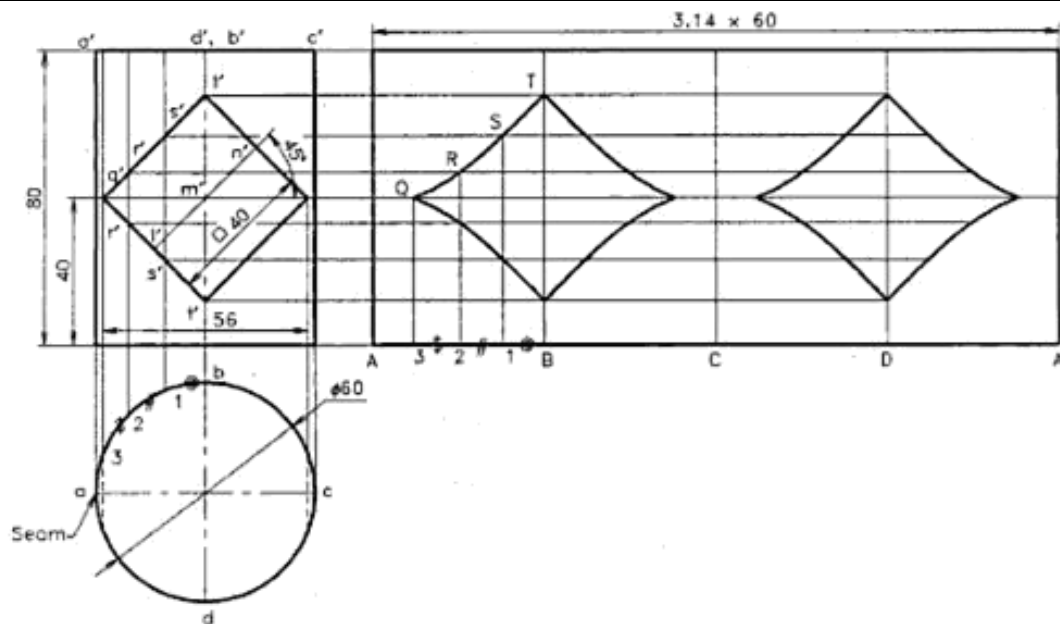

Fig. 15.15 Lateral surface of a cylinder with a hole.

axis. Construct the required square by drawing lines parallel and perpendicular to this line.

2. Draw the development of the lateral surface of the cylinder and locate the seam at the left side of the top view. Also mark the lines B, C, and D to represent the quadrants of the cylinder on the pattern.
3. Mark q' and t' at the corners of the hole and two intermediate points r' and s' between them so that, the generators through these points locate 1, 2, and 3 in the top view at almost equal distances along the perimeter.
4. Using a bow divider measure the distance from b to 1 in the top view and mark it to locate the generator 1 on left side of line B in the development. Similarly, measure distances from 1 to 2 as well as 2 to 3 and locate the 2nd and 3rd generators on left side of B as shown. Draw horizontal lines through q' , r' , s' and t' to intersect the generators drawn at 3, 2, 1 and B on the pattern, giving points Q, R, S and T respectively. Join them by curves to get one side of the hole. Take a mirror image of the curves to get the full hole.
5. Repeat the same about the fold line D also to get the second hole on the development.
6. Finish the views using proper line types and print the given dimensions to complete the drawing.

Example 15.13

A cone of base diameter 80 mm and height 80 mm is resting upon HP on its base. A horizontal square through hole of 40 mm side is cut in the cone in such a way that the axis of the hole intersects the axis of the cone at a height of 16 mm from the base. If the four sides of the hole are equally inclined to HP, draw the development of the lateral surface of the cone.

Refer to Fig. 15.16.

1. Draw the top and front views of the cone and mark the square hole in the given position. For this draw a line $l'm'n'$ of length 40 mm at an angle of 45° , keeping the mid point m' as the centre of hole on the axis. Construct the required square by drawing lines parallel and perpendicular to this line. Also locate the seam at the left side of the top view.
2. After measuring the true length of the generator TL and calculating the angle $\theta = 360 \times R/TL = 161^\circ$, draw the development of the uncut cone. Mark the four quadrant generators $abcd$ in the top view, $a'b'c'd'$ in the front view and the corresponding ABCD in the development as shown in figure.
3. The square hole is symmetrical about the line $o'b'$. To draw the left half of the development of the hole, mark the generators 1', 2' and 3' as shown in the front view and project to the top view to get the same points as 1, 2 and 3. To mark these generators in the pattern, measure the chordal distances b to 1,

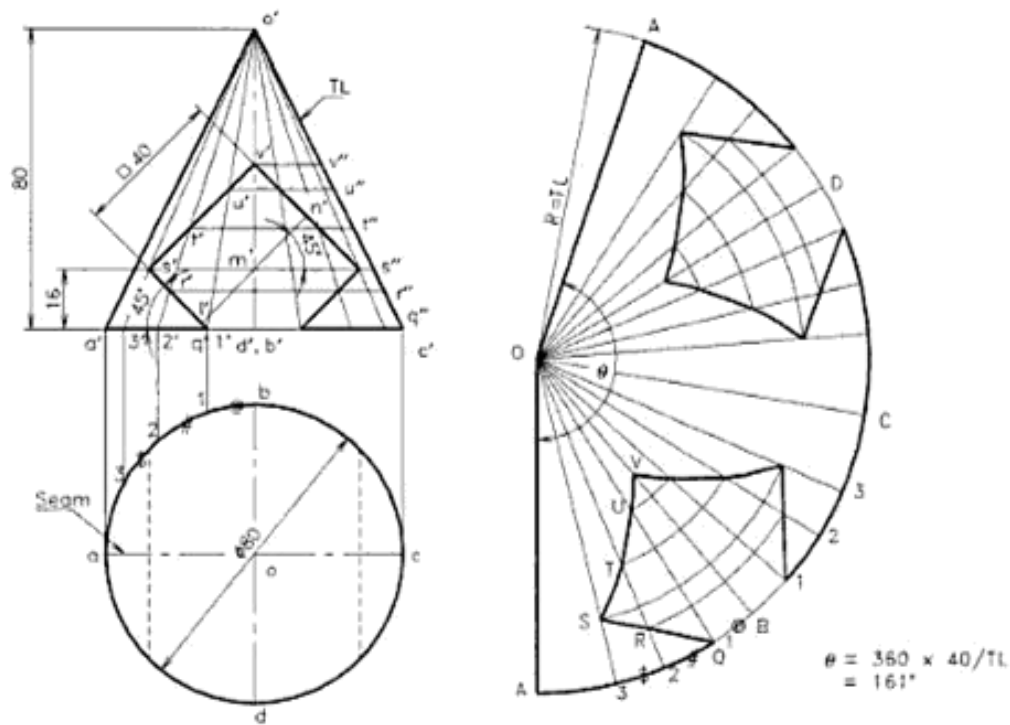

Fig. 15.16 Lateral surface of a cone with a square cut.

- 1 to 2 and 2 to 3, using a bow divider and mark the same on the left side of the line OB. (This kind of marking on small distances may result a shortening of a small % in length. This error is negligible.)
4. In the front view, name the intersecting points of generators 1, 2 and 3 with the left side edges of the hole as q' , r' , s' , etc. and draw horizontal lines through the points in order to get q'' , r'' , s'' , etc. on the true length line TL.
5. To locate a point, say S, measure the true distance $o's''$ from the front view and mark it as OS along the generator O_3 in the pattern. Similarly, mark the remaining points and join them by a smooth curve as shown in the figure. Repeat the same on the right side of OB to complete one hole. Copy the same hole about the generator OD to complete the development of the cone.
6. Finish the views using proper line types and print the given dimensions to complete the drawing.

Example 15.14

Development of a cone is a semicircle with radius 60 mm. A circle of maximum diameter is inscribed on the development and then it is rolled back to the cone. Draw front and top views of that cone showing the circle.

Refer to Fig. 15.17.

1. Draw a semicircle of radius 60 mm as the development of the cone and inscribe the largest circle (diameter 60 mm) at the middle of it as shown.
2. Divide the development radially into 12 equal parts and name the intersection points on the circle as PQRSTU.
3. Calculate the diameter of the cone corresponding to the semicircular development (cone diameter = 60 mm) and draw the top and front views of the cone. Mark the 12 generators on the views.
4. Locate the points p'' , q'' , r'' , etc. on the true length line TL corresponding to the distances OP, OQ, OR, etc. marked from the apex o' . Draw horizontal lines from these points to get p' , q' , r' , etc. on the respective generators. Join them by a smooth curve to obtain the front view of the inscribed circle.
5. Project from these points downwards to intersect on the respective generators on the top view, locating points p , q , r , etc. Join them by a smooth curve to complete the top view.
6. Mark the seam and finish the views using proper line types.

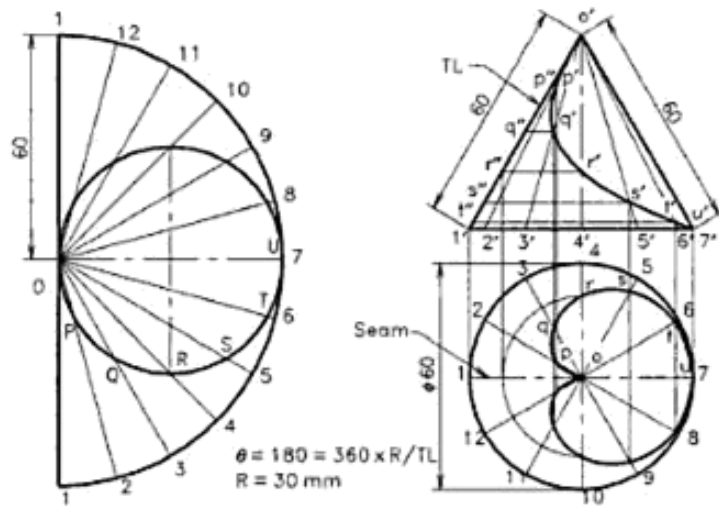

Fig. 15.17 A cone made of a semicircular lamina with a circular hole.

15.7 DEVELOPMENT OF TRANSITION PIECES

Transition piece is a part of a component whose surface transforms from one shape to another. A transformer is called a rectilinear transformer, if its surface is bound by straight lines. A *rectilinear transformer* is shown in Fig. 15.18(c).

The exact development of the rectilinear transformer is possible by the method of triangulation. This is the process of dividing the surface of an object into a number of triangles. However, the surface of the object is curved, triangulation will introduce some error.

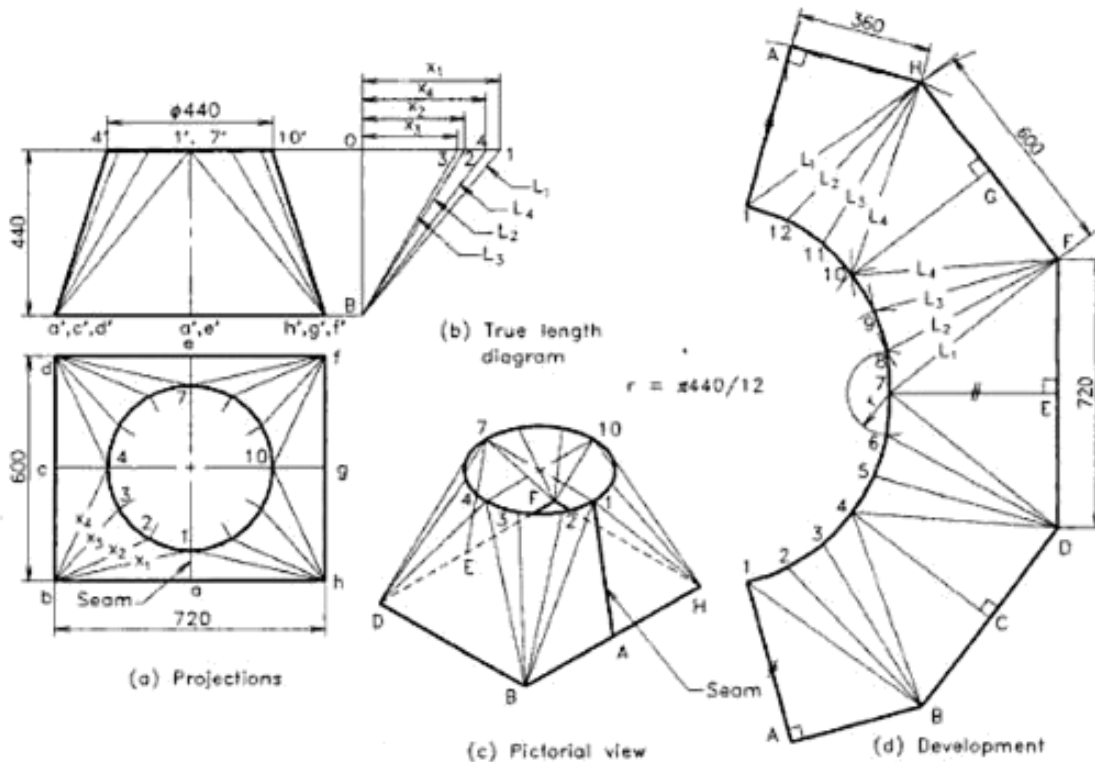

Fig. 15.18 Transition piece (rectangle reducing to circle) (Triangulation method).

- top face, by the shortest route along the front side. Sketch the path in the elevation. (#)
4. A right circular vertical cylinder of 46 mm diameter and height 50 mm rotates uniformly. A plotter pen-tip moves vertically at uniform speed on the surface of the cylinder from the bottom to the top, so it moves 50 mm while the cylinder completes one rotation. Draw the line marked on the cylinder in the front view and measure the true length of it. (#)
 5. A right circular cone has 60 mm diameter and 70 mm height. Draw the complete development of the cone showing the twelve generators. (#)
 6. Draw the development of a right circular cone of base diameter 70 mm and height 72 mm resting upon HP on its base. An insect moves from a point on the base edge to the diametrically opposite point on the same edge through a shortest path along the curved surface on front side. Mark the shortest path in the front and top views of the cone. (#)
 7. A right regular hexagonal prism of base edge 22 mm and height 60 mm rests on its base with one of its base edges perpendicular to VP. A section plane inclined 40° to HP cuts its axis at its middle. Draw the complete development of the truncated prism including the sectioned surface. (#)
 8. A right regular pentagonal pyramid, side of base, 36 mm and height 64 mm, rests on its base upon the ground with one of its base sides parallel to VP. A section plane perpendicular to VP and inclined at 35° to HP cuts the pyramid, bisecting its axis. Draw the development of the truncated pyramid. (#)
 9. Draw the development of the lateral surface of the truncated right circular cylinder of diameter 50 mm and height 80 mm. The tube is placed on HP. A section plane, passing through the geometrical centre of the top face of the tube, perpendicular to VP and inclined at 40° to HP, cuts off the top portion of the tube. A similar sectional plane making an angle of 35° to HP in the opposite direction, cuts the axis at a height of 16 mm from the base. (#)
 10. A right circular cone, 80 mm base and 80 mm height, rests on its base on the ground plane. A section plane perpendicular to VP and inclined at 45° to HP cuts the cone, bisecting its axis. Draw the development of the lateral surface of the cone. (#)
 11. A square prism of 50 mm side length and 70 mm height rests on its base upon HP, such that the vertical faces are equally inclined to VP. A horizontal hole, 50 mm diameter is drilled through the geometrical centre of the prism with the axis perpendicular to VP. Develop the lateral surface of the prism. (#)
 12. A vertical cylinder of diameter 70 mm has a central horizontal square through hole of side 48 mm. The centre of the hole is coinciding with the centre of the axis of cylinder and the sides are equally inclined to HP. Draw development of the lateral surface of the cylinder with hole. (#)
 13. A cone of base diameter 76 mm and height 76 mm is resting upon HP on its base. A horizontal square through hole of 36 mm side is cut in the cone in such a way that the axis of the hole intersects the axis of the cone at a height of 14 mm from the base. If the four sides of the hole are equally inclined to HP, draw the development of the lateral surface of the cone. (#)
 14. Development of a cone is a semicircle with radius 70 mm. A hole of maximum diameter is cut on the development and then it is rolled back to the cone. Draw front and top views of that cone showing the cutting of the hole. (#)
 15. Draw the development of a transition piece connecting a 50 cm diameter pipe and a 80 cm \times 64 cm rectangular pipe. Height of transition piece is 48 cm. The centre lines of both the circular pipe and the rectangular pipe are vertical and are in alignment. (#)
 16. A transition piece connects a 40 cm square pipe at the top and a 80 cm circular pipe at the bottom. If the centre line of the circular pipe coincides with the geometrical centre of the square pipe in the top view and the height of the transition piece is 40 cm, draw its development. (#)
 17. Develop the lateral surface of a 90° pipe elbow. Each pipe has a diameter of 500 mm. The maximum length of one leg of the elbow is 700 mm. (#)
 18. Develop lateral surface of a three piece pipe bend of 90° . The pipe has a diameter of 500 mm. The heel radius is 750 mm and the throat radius is 250 mm resulting a centre line radius of 500 mm. (#)
 19. Draw the development of the sheet metal tray shown in Fig. 15.28 and show the given dimensions on the pattern. Layout the developed pieces in order to cut them from a minimum size of sheet. (#)
 20. Draw twelve piece development of the surface of a sphere of diameter 100 mm. Use Lune method. (#)
 21. Draw eight piece development of surface of a sphere of diameter 70 mm. Use Zone method. (#)

Isometric Projection

Isometric projection is a pictorial projection of an object in which a three-dimensional view of an object is shown on a two-dimensional drawing sheet. This projection shows view of three faces of the object equally and hence, it is helpful even to a layman for the proper understanding of the shape of object. It is used by construction engineers for the preparation of pictorial views at the work site as well as by design engineers in the design and development of new or complicated parts, when the shape is difficult to understand from the multiview projection. Three-dimensional piping network can be easily represented by isometric projection. Isometric projection is found more suitable for getting pictorial views of comparatively small objects, because the perspective effect is not considered here.

16.1 PRINCIPLE OF ISOMETRIC PROJECTION

Isometric projection is one of the axonometric projections as explained in Section 9.1 of Chapter 9. It is a pictorial orthographic projection of an object in which a transparent cube containing the object is tilted until one of the solid diagonals of the cube becomes perpendicular to the vertical (picture) plane and the three axes of the cube are equally inclined ($35^{\circ}16'$) to this vertical plane.

Isometric projection of a cube can be theoretically obtained by employing the change of position method and is

shown in Fig. 16.1. Here, the third elevation $d'b'c'd'e'f'g'h'$ is the isometric projection of the cube. The front view of the cube is resting on one of its corners (g') on the ground with a solid diagonal $e'c'$ perpendicular to VP. This view (front view) shows the right, top and left square faces of the cube as rhombus with equal measure "Isometric". It is to be noted that the three faces together form a regular hexagon with inclined edges at 30° to horizontal. The isometric projection of the cube is alone reproduced in Fig. 16.2. In order to distinguish the isometric projection from the usual front view, capital letters are used in this book.

When the three axes (the three mutually perpendicular edges $c'a'$, $c'f'$, and $c'h'$ of the cube in the front view of Fig. 16.1) are equally inclined $35^{\circ}16'$ to the vertical (picture) plane, the edges $g'f'$ and $g'h'$ are seen 30° inclined to the reference line, while the $g'e'$ is seen vertical. Since the edges are equally inclined to VP, they are equally foreshortened to a value of cosine of $35^{\circ}16'$ (approx. 82%). The pictorial view formed by isometric projection can be drawn directly from the projections of the solid in simple position. Figures 16.3 and 16.4 show the method applied to a cube and a rectangular prism. Here, the x and y direction measurements are marked at 30° to the horizontal towards right and left respectively, while the z direction vertical upwards as shown. The edge lengths are marked along these axes after foreshortening to 82%.

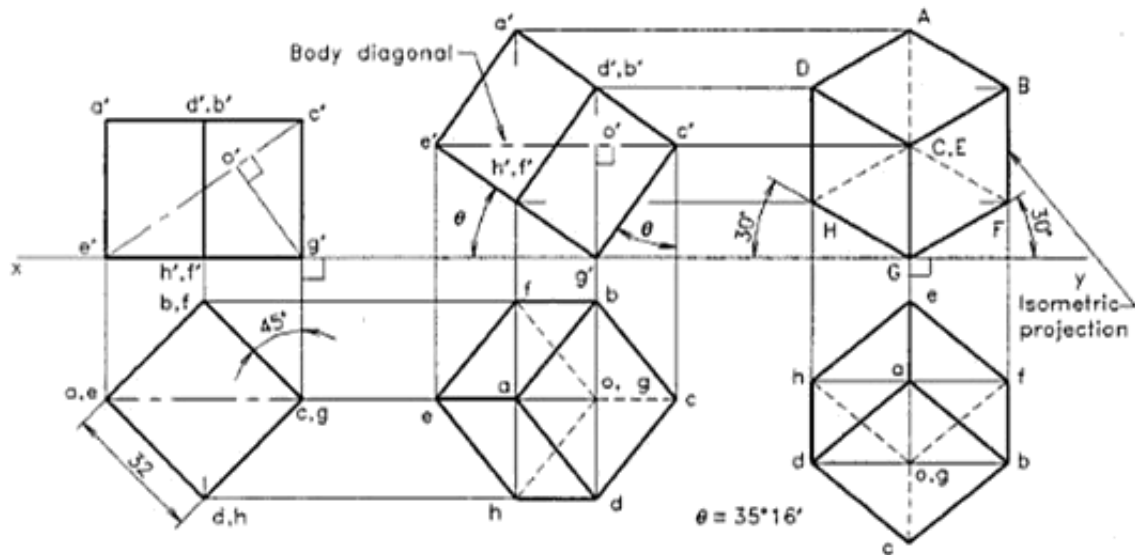

Fig. 16.1 Isometric projection from conventional orthographic projections.

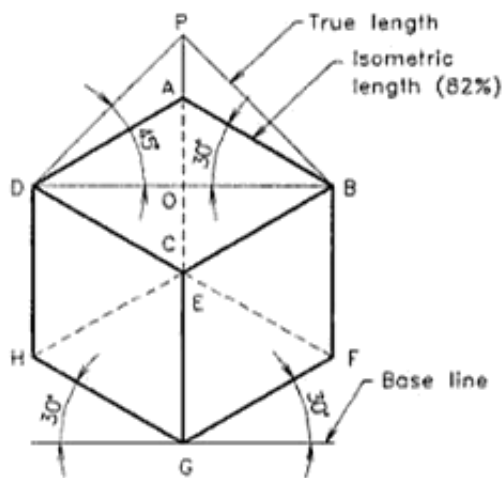

Fig. 16.2 Isometric projection from conventional orthographic projections.

16.2 ISOMETRIC SCALE

In the isometric projection of a cube shown in Fig. 16.2, the top face ABCD is sloping away from the observer and hence the edges of the top face will appear foreshortened. The true shape of the triangle DAB is represented by the triangle DPB.

The extent of reduction of an isometric line can be easily found by constructing a diagram called *isometric scale*. For this, reproduce the triangle DPA as shown in Fig. 16.5. Mark the division of true length on DP. Through these divisions draw vertical lines to get the corresponding points on D'A'.

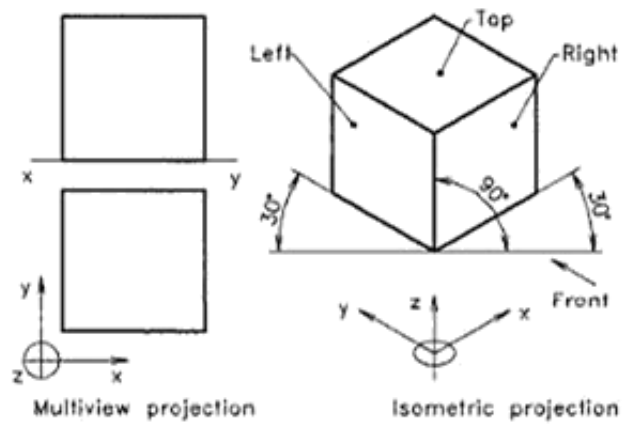

Fig. 16.3 A cube.

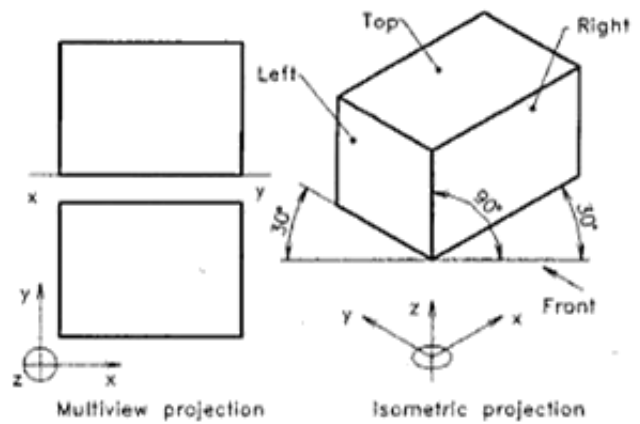

Fig. 16.4 A rectangular prism.

Urheberrechtlich geschütztes Material

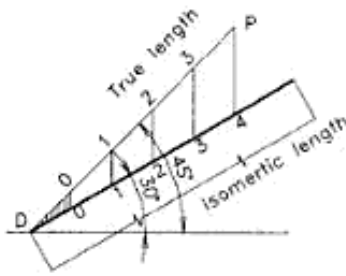

Fig. 16.5 Construction of isometric scale.

The divisions of the line DA give the dimensions to isometric scale.

From the triangles ADO and PDO, the ratio of the isometric length to the true length.

$$\text{i.e. } DA/DP = \cos 45^\circ / \cos 30^\circ = 0.816 \text{ (cosine of } 35^\circ 16')$$

The isometric axes are reduced in the ratio

$$1: 0.816, \text{ i.e. } 82\% \text{ approximately.}$$

The isometric scale can be drawn in a simple form as shown in Fig. 16.6. The true length is marked as AB. A line AC is drawn at 15° to AB to intersect another line inclined at 45° to

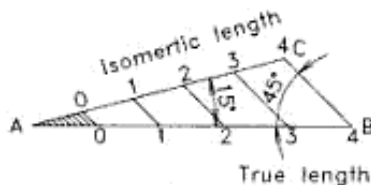

Fig. 16.6 Simplified isometric scale.

horizontal and drawn from B. Then 45° inclined lines are drawn from the divisions on the true length scale AB, so that the corresponding isometric lengths are obtained on the line AC. Even though it is easy to calculate the isometric lengths (82%) with the help of a calculator, it is a custom to show isometric scale nearby the isometric projection (on top or right side) for identification.

16.3 PROCEDURE FOR DRAWING ISOMETRIC PROJECTION

Even though the isometric projection of an object can be drawn by ordinary change of position of view method or auxiliary projection method, they are time consuming and tedious. With the help of the top and front views in simple position, the isometric projection of an object can be directly drawn by using any one or a combination of the two following methods:

1. Box method
2. Coordinate or offset method.

Box Method

In this method, the object is assumed to be enclosed in a transparent rectangular box of size just to fit the object, at the same time the sides of the box are parallel to the three reference planes. This transparent box is drawn first, over the top and front views using thin lines.

The zero position of the x, y and z axes of measurements and their +ve directions are marked in the top view as given in Fig. 17.7(a). Let the zero position be at the corner a (the

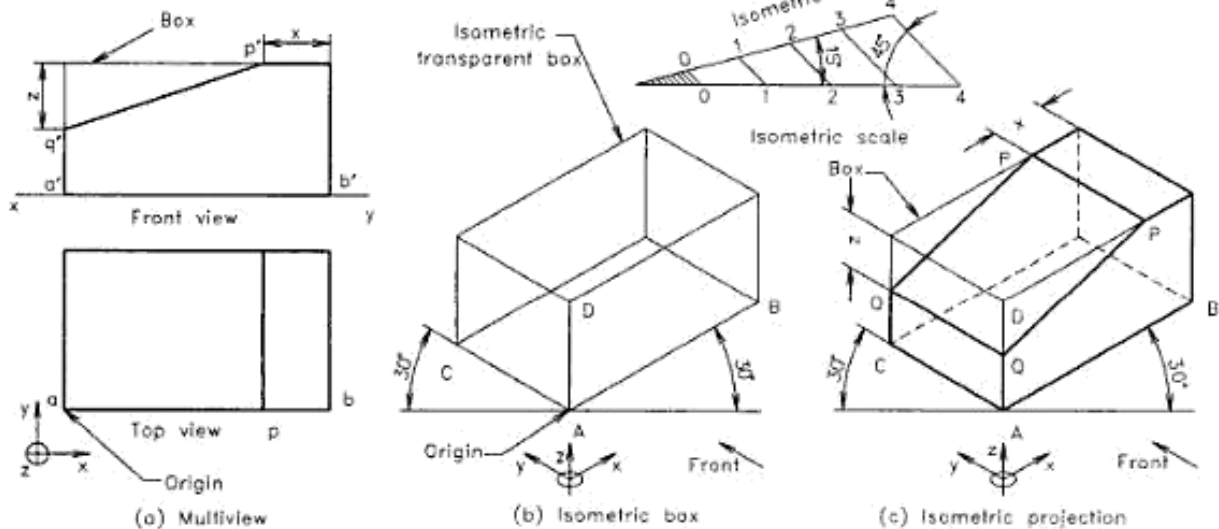

Fig. 16.7 Isometric projection (box method).

'origin'). The circle with '+' mark may be assumed the upward direction from the plane of paper.

After drawing an isometric scale, the isometric drawing can be started. From the orthographic views, take the dimensions in the x , y , z directions from the 'origin' a , convert them into isometric lengths (either by using isometric scale or by using calculator) and draw the transparent box [Fig. 16.7(b)]. For this, draw a horizontal reference line of short length and mark point A (origin) at the middle of it. Draw two 30° inclined lines and a vertical line through the point A to locate the three isometric axes AB, AC, and AD respectively to represent the mutually perpendicular edges of the box in isometric projection.

After completing the box, the object is constructed inside, relative to the edges of the box (see Fig. 16.8(c)). On the isometric box the line PP can be marked by locating distance ' x ' multiplied by 0.82 from the end face of box. Similarly, the line QQ can be marked from top face at ' z ' distance in isometric length. By marking various points in the respective xyz directions using isometric lengths and converting the thin lines representing the object to the visible and hidden edges, the isometric drawing is completed.

the isometric drawing by coordinate method. After drawing the top and front views and the isometric scale, the construction of the isometric projection is started by drawing the base of the object. As is done in the box method, the horizontal reference line of short length is drawn and the zero position of the axes (point A) is marked at the middle of it. Now, the 30° lines are drawn to locate the isometric x and y axes. The base of the object is now completed in the x and y directions giving the isometric rectangle. The vertical height points are then marked by measuring the z values from the front view and converting them to the isometric lengths. For example, to get point p , the height z is marked at x distance along the x axis. After marking all the required points and converting the thin lines representing the object to the visible and hidden edges, the isometric drawing is completed.

Coordinate or offset method is best suited for objects containing a large number of non-isometric lines and planes. For certain shapes, a combination of the two methods may have to be applied to get the drawing in a shorter time. It is to be noted that, in isometric projection all the measurements are taken in the x , y , z directions only and they are marked along the respective isometric axes after multiplying by the isometric scale factor 0.82.

Coordinate or Offset Method

In this method, one of the three isometric planes (top, left or right) is taken as the reference plane and the end points of the edges of the object are marked along an axis perpendicular to this reference plane. Figure 16.8 shows the construction of

Hidden Lines

The hidden edges of the isometric projections are represented by short dashes (Type E or F) and the rules for drawing them are the same as followed for multiview projection. Hidden

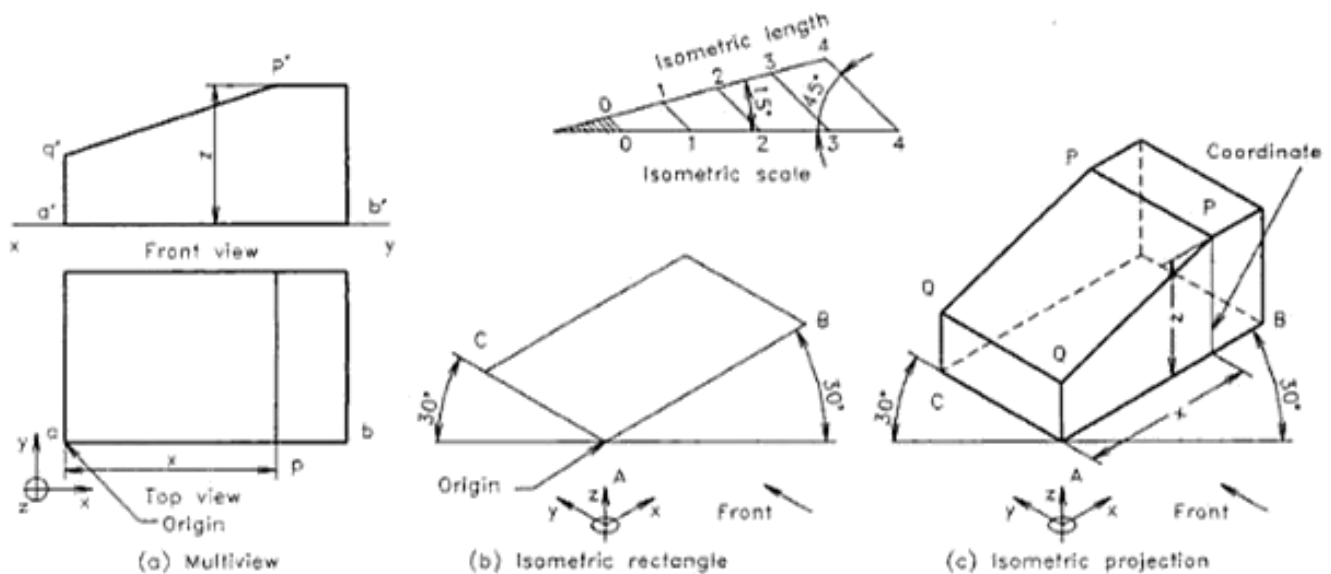

Fig. 16.8 Isometric projection (coordinate method).

lines are generally omitted in isometric projection of objects having a number of hidden edges, because drawing of these lines will reduce the clarity. But simple objects as well as objects requiring the drawing of hidden details, are provided with the invisible informations of the shape.

Selection of Isometric Axes

The isometric axes may be placed in any desired position with respect to the objects. Generally, the axes are determined by the position from which the object is usually viewed or by the position which describes the shape of object more clearly. Figure 16.9 shows the result of varying the origin of the axes and their directions. Here, the second isometric view, showing the top side and keeping the origin at B, gives a better clarity to the shape. To show the bottom side of the object, the third or fourth position may be selected.

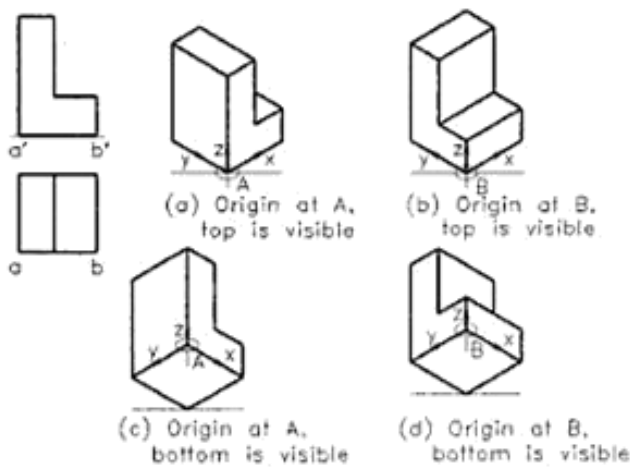

Fig. 16.9 Isometric projection of various axis positions and directions.

Dimensioning

The general rules for the dimensioning of multiview projection is applicable for isometric projection also, except the following.

1. All the extension lines and dimension lines should be parallel to the isometric axes and they should lie on any of the isometric planes.
2. The text should be placed at the middle of the dimension line, after breaking it for a short length.
3. The dimensional values in x direction should be readable from the right side, while those in y direction should be readable from the left side. The dimensional values in z direction should be readable horizontally from the right side.

4. The numerals placed along the three axes should be aligned with the direction of the axes.

Figure 16.10 shows the recommended dimensioning layout for isometric drawing by B.I.S.



Fig. 16.10 Dimensioning of isometric drawings.

16.4 ISOMETRIC PROJECTION AND ISOMETRIC VIEW

As discussed earlier, isometric projection of an object is the front view of the object placed in the isometric position. Isometric projection is the actual projection of the object on VP. Here, as the edges of the transparent cube are inclined $35^{\circ}16'$ to VP, their projection on VP will have a length of about 82% of the true length, when measured in the isometric position.

To avoid the difficulty in determining the foreshortened lengths, the foreshortening of the axes may be ignored. Hence, isometric projection can be drawn directly, using the true length of the edges of the cube along the isometric axes. As a result, the projection obtained is larger in size than the actual. This projection is called *isometric view* or *isometric drawing*. Thus in short, as the length of the edge of the cube, which are inclined to VP, are taken as equal to the true length of the object itself, the view obtained will be larger than the isometric projection. This enlargement will be to the tune of $1/0.816$ (i.e. 22.5% larger).

An isometric projection and an isometric view of a cube are shown in Fig. 16.11.

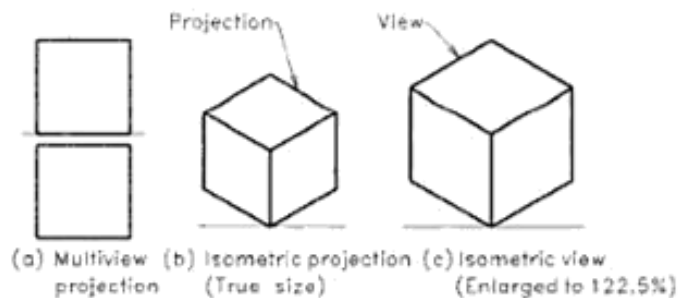

Fig. 16.11 Comparison between isometric projection and isometric view.

Notes:

1. An isometric projection of the x, y, z axes are equally inclined to the vertical plane, hence the edges of the object which are parallel to them are foreshortened (to about 82%).
2. The three isometric axes form the three isometric planes namely left, right and top.
3. All the dimensions are measured and marked along the isometric axes only.
4. Isometric projection is the actual size of the pictorial view after foreshortening the true length to about 82%. The isometric scale is drawn nearby the figure to identify the isometric projection.
5. A line or plane which is not parallel to the three axes or the three planes, is called a non-isometric line or plane.
6. The location of the origin of axes may be suitably selected to show maximum details clearly. Generally the front side may be taken towards left or towards right, suitable to the object.
7. Drawing of the isometric projection or view may be done using box method, coordinate (offset) method or a combination of the two.
8. The hidden edges are shown usually for simple objects only or for indicating certain important hidden details.
9. The edge of isometric projection or view are named using capital letters.
10. Isometric drawings are dimensioned along the three axes only.
11. The dimensional value is entered at the middle of the dimension line, after breaking it for a short length. The text should be entered along the directions of x and y . For z direction it should be readable from right side.

16.5 PLANE FIGURES

Isometric projection or view of plane figures are generally drawn on any one of the isometric planes such as top, right or left.

Pentagonal Lamina

Figure 16.12 shows isometric projection of a pentagonal lamina. Here the lamina is kept parallel to HP so that the top isometric plane is seen. To get the projection, the top view of lamina is enclosed in a rectangle 1234 and the origin is marked. Draw a reference line and mark point 1 at the middle of it. Construct the isometric rectangle 1234, parallel to the isometric axes x and y , after converting the side length as per

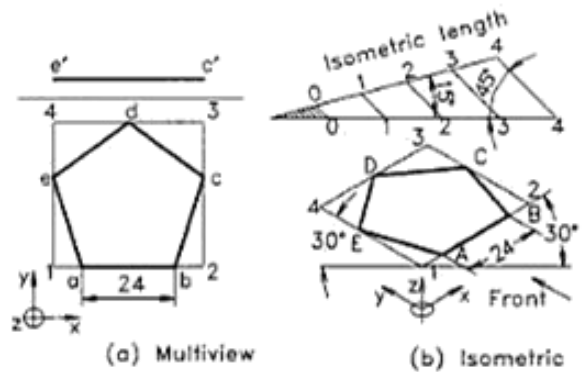

Fig. 16.12 A pentagonal lamina.

the isometric scale. To mark point A, measure the distance in the top view from 1 to a, convert that to isometric length and mark it along the isometric x -axis. Similarly, locate the remaining points BCDE on the isometric rectangle. Join the points by thick line to complete the isometric projection on the top plane.

Circular Lamina

Figure 16.14 shows isometric views of a circular lamina of 50 mm diameter, seen on left, top and right planes as ellipses. To get the views, enclose the given circle in a square 1234.

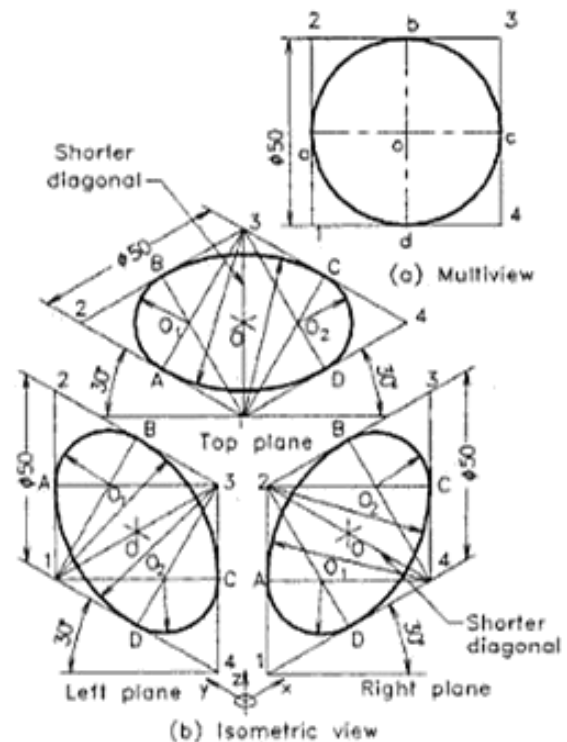

Fig. 16.13 A circular lamina (four-centre construction).

Urheberrechtlich geschütztes Material

Construct three isometric squares (rhombus) of 50 mm side for the left, top, and right faces as shown in figure. Since the isometric view (not the projection) is required, there is no need of drawing the isometric scale and foreshorten the lengths. In an isometric view, a circle is seen as an isometric circle, i.e. ellipse.

The isometric circle (ellipse) may be constructed approximately by arcs using the four centre method. To locate the four centres and the ends of arcs, join the mid points A, D to the corner 3 and B, C to the corner 1 of the shorter diagonal in the top isometric plane. The intersection points O_1 and O_2 are the centres for short arcs, while the corners 1 and 3 are the centres for long arcs. Draw the short arcs AB and DC with centres O_1 and O_2 respectively. Similarly, draw long arcs BC and DA with centres 1 and 3 respectively to complete the approximate ellipse. The same is repeated on the other two faces to get the isocircles.

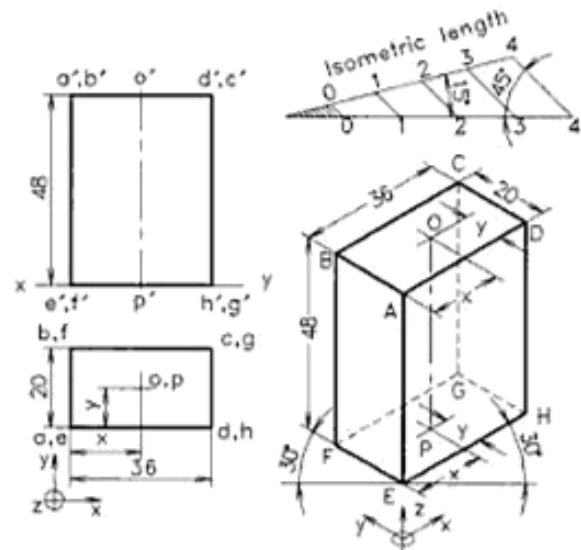

Fig. 16.14 Isometric projection.

16.6 SOLIDS

Isometric projection or view of a solid can be drawn by following the box method or coordinate method explained earlier. The isometric circles may be easily drawn by using the four centre method. The following examples explain the procedure of drawing.

Example 16.1

Draw the isometric projection of a rectangular prism of side of base 36 mm \times 20 mm and height 48 mm, resting upon its base on HP and the 36 mm long edges are parallel to VP.

Refer to Fig. 16.14.

1. Draw multi-view projection of the prism in the given position and name the corners. Locate the origin of axes on the left side of top view in order to get the front view on the right isometric plane.
2. Construct the isometric scale as explained earlier (Fig. 16.6) on the top or right side of the area provided for the isometric projection.
3. Draw a short horizontal thin line and mark the mid point of it as the origin (corner E) of the isometric axes xyz . From the origin draw 30° inclined line EH towards right to represent x direction and another 30° line EF towards left to represent y direction. The vertical line EA upwards represents the z axis. A symbol for isometric axes may also be marked below this origin as shown in figure for identifying the directions without mistakes.
4. From the top view take the distance eh along x direction, multiply it by 0.82 and mark it along the x isometric axis as EH. Again from the top view

take the distance of ef along y direction, multiply it by 0.82 and mark it along the y isometric axis as EF. Similarly, from the front view take the distance $e'a'$ along z direction, multiply it by 0.82 and mark it along the z isometric axis as EA. Repeat the same for all edges along xyz directions to get the isometric projection, drawn in thin lines.

5. To locate the vertical axis OP, measure the x and y distances of o, p from the top view, multiply it by 0.82 and mark it along the x and y isometric axes from the corner E at the bottom, as well as from A at the top corner of the isometric box. Join OP by chain line along the z axis to indicate the axis.
6. Convert the thin lines to visible and hidden edges as done for projections of solids. Name the corners and axis using capitals, and print the given dimensions as permitted for pictorial views (Refer Fig. 16.10) to complete the drawing.

Example 16.2

Draw isometric view of a hexagonal prism of 50 mm height and side 20 mm long, lying on HP with the axis perpendicular to VP. Select the origin of the isometric axes suitable to get the front view on the left isometric plane.

Refer to Fig. 16.15.

1. Draw the multiview projection of the prism in the given position.
2. Enclose the front view in a box $1'2'3'4'$ and locate the origin of the isometric axes on the right corner of the top view in order to get the front view on the left (yz) isometric plane as shown.

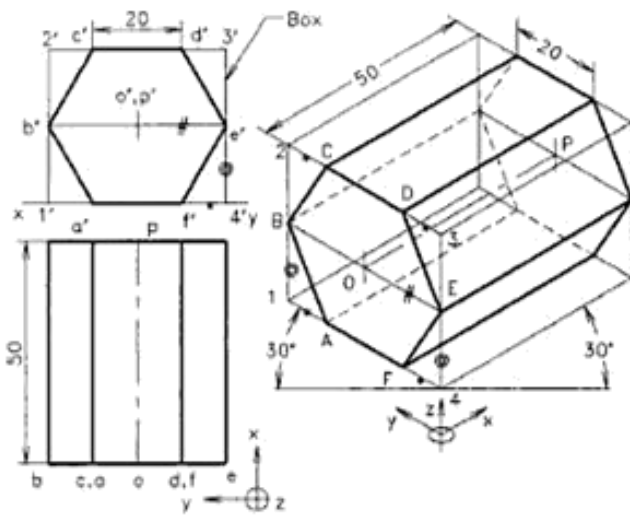

Fig. 16.15 Isometric view (box method).

3. Draw a short horizontal thin line and mark the mid point of it as the origin (4) of the isometric axes xyz . From the origin (4) draw 30° inclined thin lines towards right and left directions to represent x and y isometric axes respectively and a vertical thin line for z axis. The symbol for isometric axes may also be marked below this origin.
4. Draw the isometric view of the box 1234 using the lengths measured along xyz directions from the front and top views as explained in Example 16.1. Here, the lengths are not foreshortened, because requirement is not an isometric projection but a view.
5. Construct the isometric hexagon ABCDEF on the left isometric plane (1234) of the box. To mark the corner F, take the distance $4'f'$ using a bow divider and mark it along the same (y) direction from 4 to F on the isometric box. Similarly to mark the corner E, take the distance $4'e'$ using a bow divider and mark it along the same (z) direction from 4 to E on the isometric box. Following the same method mark the remaining corners of the hexagon at the relative positions to the box corners 1234 along the x , y and z directions. Repeat the same for the back hexagonal face of the prism. Complete the view by joining the front and back corners with thin lines along the x direction.
6. To locate the horizontal axis OP, join BE, and mark O the mid point as one end of axis. Similarly, on the back face locate P and join OP by chain line to indicate the axis.

7. Convert the thin lines to visible and hidden edges as done for projections of solids. Name the corners and axis using capitals, and print the given dimensions as permitted for pictorial views (Refer Fig. 16.10) to complete the drawing.

Example 16.3

Draw isometric view of a cylinder of 50 mm height and diameter 40 mm, lying on one of its generators on HP with the axis perpendicular to VP. Select the origin of the isometric axes suitable to get the front view on the left isometric plane.

Refer to Fig. 16.16.

1. Draw the multiview projection of the cylinder in the given position.
2. Enclose the front view in a square box 1'2'3'4' and locate the origin of the isometric axes on the right corner of the top view in order to get the front view on the left (yz) isometric plane as shown.
3. Draw a short horizontal thin line and mark the mid point of it as the origin (4) of the isometric axes xyz . From the origin (4) draw 30° inclined thin lines towards right and left directions to represent x and y isometric axes respectively and a vertical thin line for z axis. The symbol for isometric axes may also be marked below this origin.
4. Draw the isometric view of the box 1234 using the lengths measured along xyz directions from the front and top views. Here, the lengths are not foreshortened, because requirement is not an isometric projection but a view.

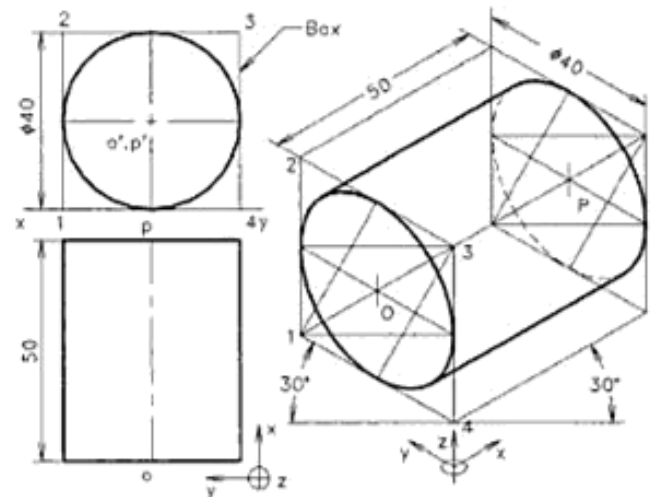

Fig. 16.16 Isometric view (box method).

Urheberrechtlich geschütztes Material

- Construct the isometric circle (four-centered ellipse) on the left isometric plane (1234) of the box as explained in Fig 16.13. Repeat the same for the back end face of the box. Complete the view by drawing tangents to the front and back ellipses with thick lines along the x direction.
- To locate the horizontal axis OP , join AC , and mark O , the mid-point as one end of axis. Similarly, on the back face locate P and join OP by chain line to indicate the axis.
- Convert the hidden edge of the cylinder (half of the back side) to short dashes. Name the axis using capitals, and print the given dimensions as permitted for pictorial views (Refer to Fig. 16.10) to complete the drawing.

Example 16.4

Draw the isometric projection of a pentagonal prism of side of base 30 mm and height 60 mm, resting upon its base on HP and a rectangular face is parallel to VP.

Refer to Fig. 16.17.

- Draw the multiview projections of the pentagonal prism in the given position.
- Enclose the object into a rectangular box and name the corners.
- Construct the isometric scale and draw the isometric projection of the box using isometric lengths. Also add the symbol for isometric axes.
- Construct the isometric pentagon in the bottom

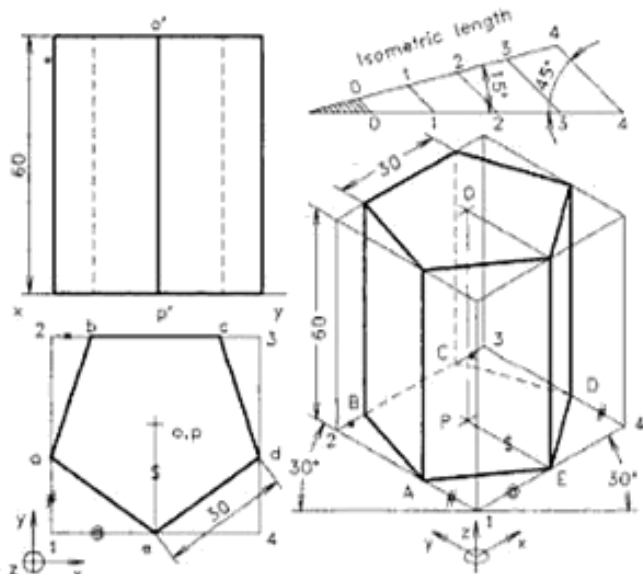

Fig. 16.17 Isometric projection (box method).

- isometric plane, using the top view lengths converted into the isometric lengths.
- Draw the parallel isometric pentagon on the top isometric plane following the same procedure and join the corners by vertical lines. Also indicate the axis OP as done in Example 16.1.
- Convert the hidden edges to short dashes, finish the view and enter the dimensions as per BIS to complete the drawing.

Example 16.5

A hexagonal pyramid of height 50 mm and side 24 mm is resting on HP, keeping its axis vertical and one edge of the base parallel to VP. Draw isometric view of the solid.

Refer to Fig. 16.18.

- Draw the top and front views of the hexagonal pyramid in the given position and enclose the top view of in a rectangle.
- Construct the isometric view of the rectangle and draw the isometric base of the hexagonal pyramid in side. Also add the symbol for isometric axes.
- Locate the centre of the isometric hexagon and draw the vertical axis OP of given length. Then join the apex O to the six base corners to complete the pyramid.
- Finish the view using proper line types, indicate the hidden portion pyramid and dimension the figure as per BIS to complete the drawing.

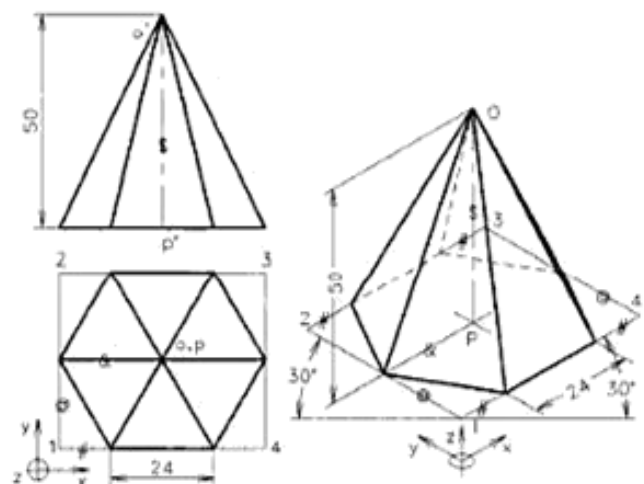

Fig. 16.18 Isometric view (coordinate method).

Example 16.6

A cone of height 50 mm and diameter 48 mm is resting on HP, keeping its axis vertical. Draw isometric view of the solid.

Refer to Fig. 16.19.

1. Draw the top and front views of the cone and enclose the top view in a square.
2. Construct the isometric view of the square and draw the isometric circle (ellipse) of the cone in side (Refer to Fig. 16.13). Also add the symbol for isometric axes.
3. Locate the centre of the isometric square and draw the vertical axis OP of given length. Then draw the outermost generators of cone by drawing tangents from O to the base (ellipse).
4. Finish the view using proper line types, indicate the hidden portion of the ellipse and dimension the figure as per BIS to complete the drawing.

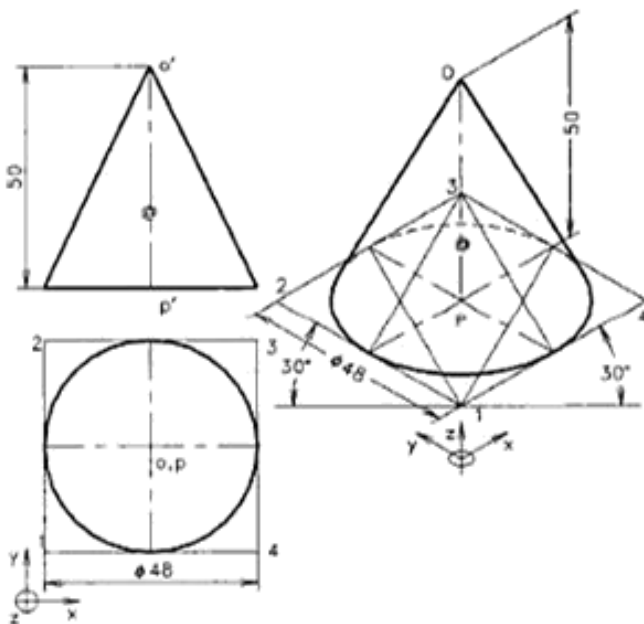

Fig. 16.19 Isometric view of solids (coordinate method).

Example 16.7

A frustum of a cone of base diameter 50 mm, top diameter 30 mm, and height 45 mm is resting upon its base on HP. Draw the isometric projection of the frustum.

Refer to Fig. 16.20.

1. Draw the top and front views of the frustum of cone and enclose the circles of top view inside squares.

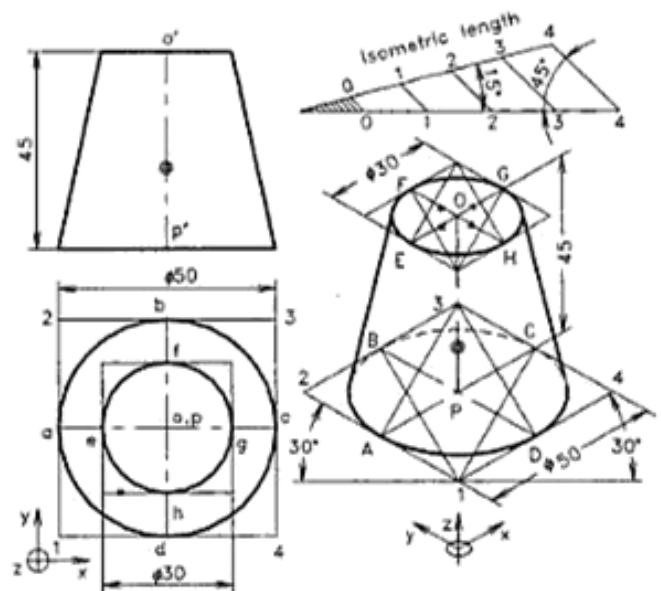

Fig. 16.20 Isometric projection of a frustum (coordinate method).

2. Construct the isometric scale and draw the isometric square 1234 for the base of the cone. Also add the symbol for isometric axes.
3. Construct the isometric circle (ellipse) ABCD inside the isometric square 1234 (refer to Fig. 16.13) and draw the vertical axis OP at the centre of it. Mark the height of the axis after converting it to the isometric length.
4. To construct the top isometric circle about the centre O, draw 30° inclined lines EG and FH through O and mark the length equal to the isometric radius of the top face of cone on them, i.e. OE = OG = OF = OH. Draw the isometric square 5678 (rhombus) parallel to these lines as given in figure and construct the isocircle (ellipse) EFGH inside.
5. Draw the outermost generators of the cone as tangents to the two ellipses. Note that all the true lengths should be multiplied by the isometric scale (82%) before marking, since an isometric projection is the requirement.
6. Finish the view using proper line types, indicate the hidden portion of the ellipse and dimension the figure as per BIS to complete the drawing.

Example 16.8

A square pyramid, edge of base 40 mm and axis 60 mm long, is lying on one of its triangular faces upon HP and its axis

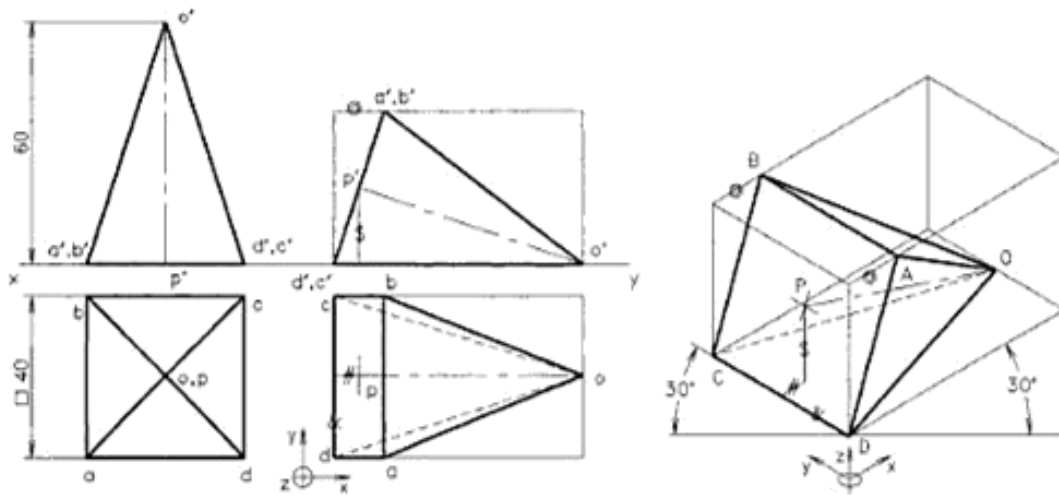

Fig. 16.21 Isometric view of a square pyramid (box-method).

parallel to VP. Draw the isometric view of the given pyramid showing the base.

Refer to Fig. 16.21.

1. Draw the front and top views of the pyramid in the given position and enclose it in a rectangular box.
2. Draw the isometric view of the box using the lengths measured along xyz directions. Also add the symbol for isometric axes.
3. Mark the base points ABCD on the box corners and edges and locate the apex O at the middle of bottom edge of the back face. Join these points using thin lines to get the view.
4. To draw the inclined axis OP, locate the end P by marking the xyz distances obtained from the top and front views as shown in the figure. Join OP by chain line to indicate the axis. A short cross mark may be shown at P for which the lines are drawn parallel to the base edges.
5. Finish the view using proper line types to complete the drawing.

16.7 SECTIONED SOLIDS

Isometric view of a solid, sectioned by a cutting plane, can be drawn by box method or coordinate method. In box method, after drawing the isometric view of the box, the cutting plane is marked in it and the cut surface is drawn on that plane. But in coordinate method, the sectioned surface is obtained by marking the coordinates of the boundary points from an isometric plane as reference. Figure 16.22 shows isometric projection of a sectioned vertical pentagonal prism using coordinate method. Similarly, Fig. 16.23 shows isometric

view of a sectioned horizontal hexagonal prism. Generally coordinate method is found more easy to get the isometric projection or view of a sectioned solid.

Example 16.9

A pentagonal prism of side of base 30 mm and height 60 mm is resting on its base upon HP, keeping one base edge parallel and nearer to VP. The prism is cut by a section plane, 30° inclined to HP and passing through a point on the axis, 40 mm above the base. Draw isometric projection of the prism showing the sectioned surface.

Refer to Fig. 16.22.

1. Draw the top and front views of the sectioned prism in the given position and name the section as 12345. Enclose the plan in a rectangle.
2. Construct the isometric scale and draw the isometric projection of the rectangle to enclose the base of the prism. Also add the symbol for isometric axes.
3. Mark the base points ABCDE on the isometric rectangle and locate the axis end P at the middle of base by measuring the distances along xy directions and multiplying by 0.82. Join these points using thin lines to get the isometric pentagon.
4. To draw the sectioned prism, measure the distance $a'1'$, multiply by 0.82 and mark it from the corner A in the z direction to obtain the vertical edge A1. Similarly, mark the remaining four vertical edges and the axis as shown in figure. Join the corners to get the projection.
5. Finish the view using proper line types and hatch the cut surface to complete the drawing.

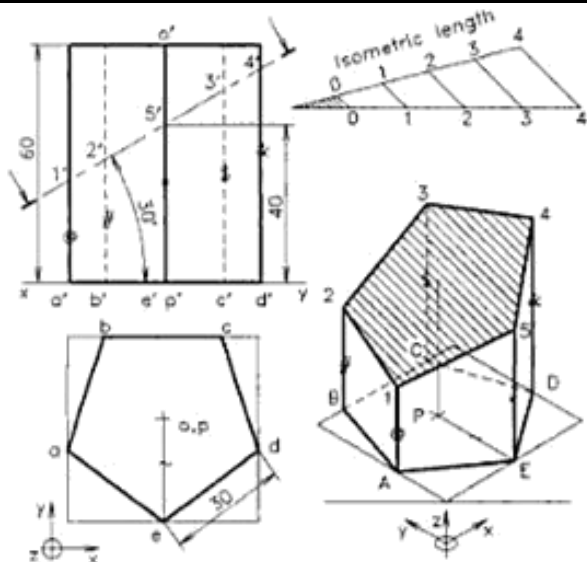

Fig. 16.22 Isometric projection (coordinate method).

Example 16.10

A hexagonal prism of side of base 20 mm and length 50 mm is resting on one of its rectangular faces upon HP, keeping the base parallel to VP. The prism is cut by a vertical section plane 30° inclined to VP and passing through the mid point on the axis. Draw isometric view of the prism showing the sectioned surface.

Refer to Fig. 16.23.

1. Draw the front and top views of the sectioned prism in the given position and name the section as 123456. Enclose the elevation in a rectangle.

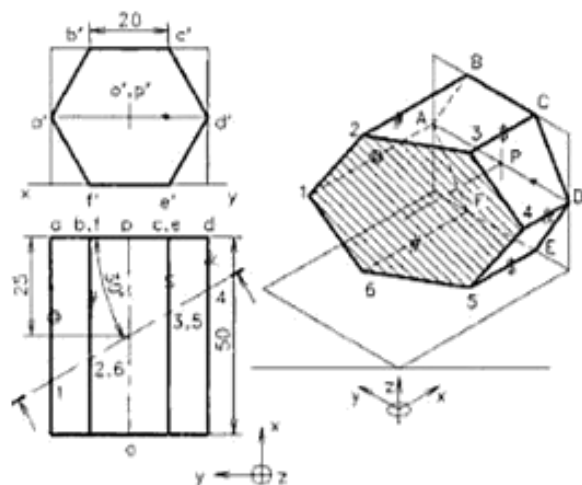

Fig. 16.23 Isometric view (coordinate method).

2. Draw the isometric view of the rectangle enclosing the plan and then construct the isometric view of the rectangle enclosing the elevation on it as shown in figure. Also add the symbol for isometric axes.
3. Mark the base points ABCDEF on the vertical isometric rectangle and locate the axis end P at the middle of base by measuring the distances along y and z directions. Join these points using thin lines to get the isometric hexagon.
4. To draw the sectioned prism, measure the distance a to 1, and mark it from the corner A in the x direction to obtain the horizontal edge A1. Similarly, mark the remaining five horizontal edges and the axis as shown in the figure. Join the corners to get the view.
5. Finish the view using proper line types and draw section lines on the cut surface to complete the drawing.

Example 16.11

A square pyramid of side of base 40 mm and height 60 mm is resting on its base upon HP, keeping the base edges equally inclined to VP. The pyramid is cut by a section plane, 30° inclined to HP and passing through the midpoint of the axis. Draw isometric view of pyramid showing the section.

Refer to Fig. 16.24.

1. Draw the top and front views of the sectioned pyramid in the given position and name the sectioned surface as 1234.

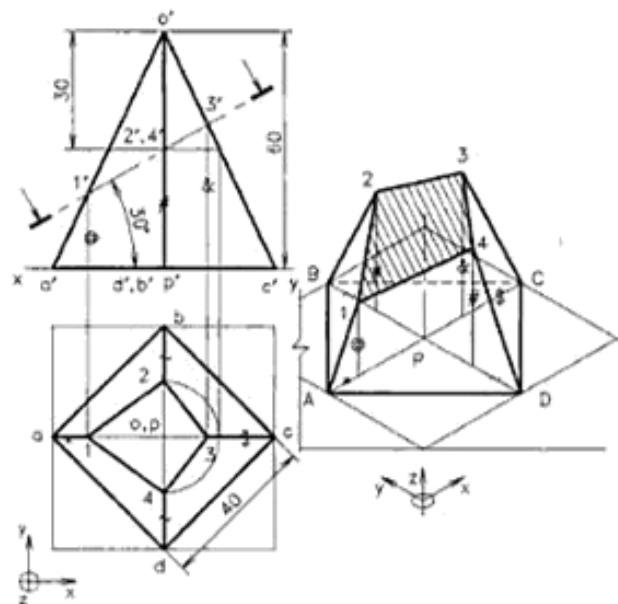

Fig. 16.24 Isometric view (coordinate method).

2. Enclose the base $abcd$ in a square as shown in the figure. Draw the isometric view of this square and mark the base points ABCD on it.
3. To locate the corners 1, 2, 3, and 4 of the cut-surface, use the coordinate method. To obtain point 1, measure the coordinate values of the point in the x , y and z directions from the top and front views respectively and mark the same along the isometric axes. Similarly locate 2, 3 and 4, and join them by straight lines to get the cut-surface.
4. Join the points 1234 to the respective base corners A,B,C and D to get the base portion of the pyramid. Locate the axis position P and draw the vertical axis through the point.
5. Finish the view using proper line types, and hatch the cut surface to complete the drawing.

Example 16.12

A cylinder of diameter 48 mm base and 60 mm height, is resting upon its base on HP. A section plane of 45° inclination to HP bisects the axis of the cylinder. Draw the isometric view of the cylinder showing the sectioned surface.

Refer to Fig. 16.25.

1. Draw the top and front views of the cylinder and mark the section plane at 45° . Enclose the base of the cylinder in a square.
2. Construct the isometric view of the square and draw an isometric circle (ellipse) inside to represent the base of the cylinder.
3. In the top view, draw diagonals to the square and mark the points 1, 2, 3, ..., 8 at the eight intersection

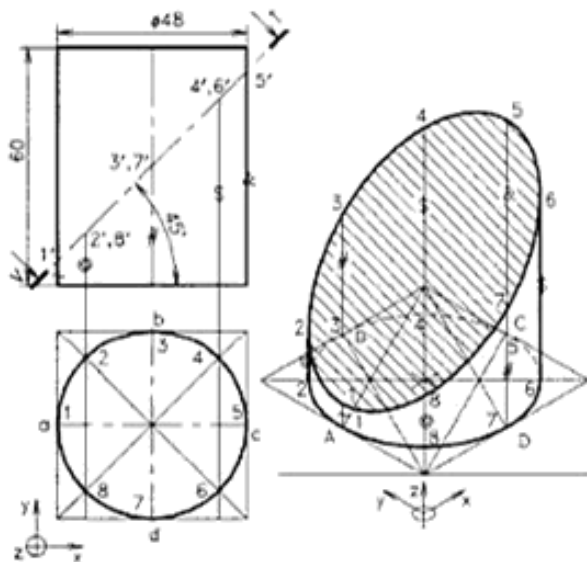

Fig. 16.25 Isometric view (coordinate method).

points of the diagonals on the circle. Mark these two diagonals in the isometric view of the square and locate the points 1, 2, 3, ..., 8 at the intersection of isocircle in the same order.

4. To construct the isometric view of the sectioned cylinder, join the points 8 and 2 in the top view, and then produce to the front view to get point $2'8'$ on the section line. This vertical line through $2'8'$ is a generator of the cylinder in the front view. Similarly, mark generators through $3'7'$ and $4'8'$ on the section line. Points $1'$ and $5'$ represent the extreme points on the section line.
5. Measure the heights (z values) of these generators from the base of cylinder to the points 1, 2, 3, ..., 8, in the front view and mark them in the same order on the isometric view as 1-1, 2-2, 3-3, ..., 8-8 in the z direction as shown in the figure. Join all the top points by a smooth curve to get the elliptical sectioned surface 1, 2, 3, ..., 8. Also draw vertical lines tangential to the two ellipses to represent the outermost generators of the cylinder.
6. Finish the view using proper line types, and hatch the cut surface to complete the drawing.

16.8 COMBINATION OF SOLIDS

Drawing procedure for the isometric projection of a combination of two or more solids is similar to that of individual solids. The point to be specially considered is the relative position of them in the isometric view. Figure 16.26 shows the isometric view of a cone placed over a square slab.

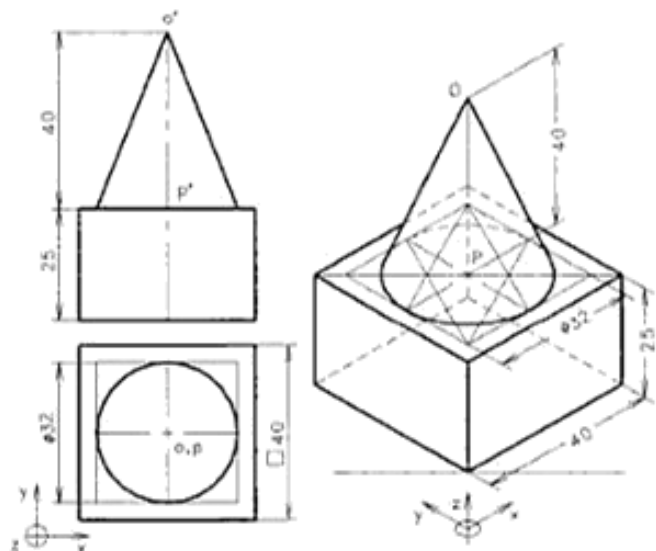

Fig. 16.26 Isometric view (combination of solids).

Here, the base of the cone is placed over the top face of the slab, so that the axes are coinciding.

When a sphere is to be drawn in combination with the another solid, care should be taken to avoid mistakes in marking the centre of the sphere. The method of drawing the isometric projection and view of a hemisphere resting on a square slab, is given Fig. 16.27.

Example 16.13

A cone of diameter 32 mm base and 40 mm height is surmounted over a square slab of 40 mm side and 25 mm thickness on HP so that one edge of the square is parallel to VP. Draw isometric view of the combination.

Refer to Fig. 16.26.

1. Draw the top and front views of the combination of solids keeping the cone centrally over the square slab. Enclose the base circle of the cone in a square.
2. Construct the isometric view of the square slab and mark point P at the middle of the diagonal of top face of the slab, as the axis end of cone. Draw an isometric square (rhombus) of 32 mm side keeping the centre at P. Construct isometric circle (ellipse) inside the rhombus to represent the base of the cone.

3. Mark the axis height OP for the cone and complete the cone by drawing tangents to the ellipse.
4. Finish the view using proper line types, indicate the hidden portions and dimension the figure as per BIS to complete the drawing.

Isometric Projection of a Hemisphere Resting on a Slab

If a hemisphere with centre O and radius R is placed on a square slab as shown in Fig. 16.24(a), the line joining the centre of the sphere o' to the point of contact of the spherical surface with the top of slab p' will be vertical in the front view. If the sphere is tilted and brought to the isometric position, the vertical distance $o'p'$ will be inclined $35^{\circ}16'$ and hence it will get foreshortened to 82% approximately as explained earlier. Thus, in the isometric projection of a hemisphere, the centre will be at a height of 82% of R from the point of contact. Here, OP is the isometric distance of $o'p'$ and is equal to $R_i = 82\%$ of R [Fig. 16.27(b)]. However, the radius of the outer surface of the hemisphere is same as SR (because there is no difference in size if a sphere is tilted) and is equal to half the major axis of the ellipse representing the top circular plane.

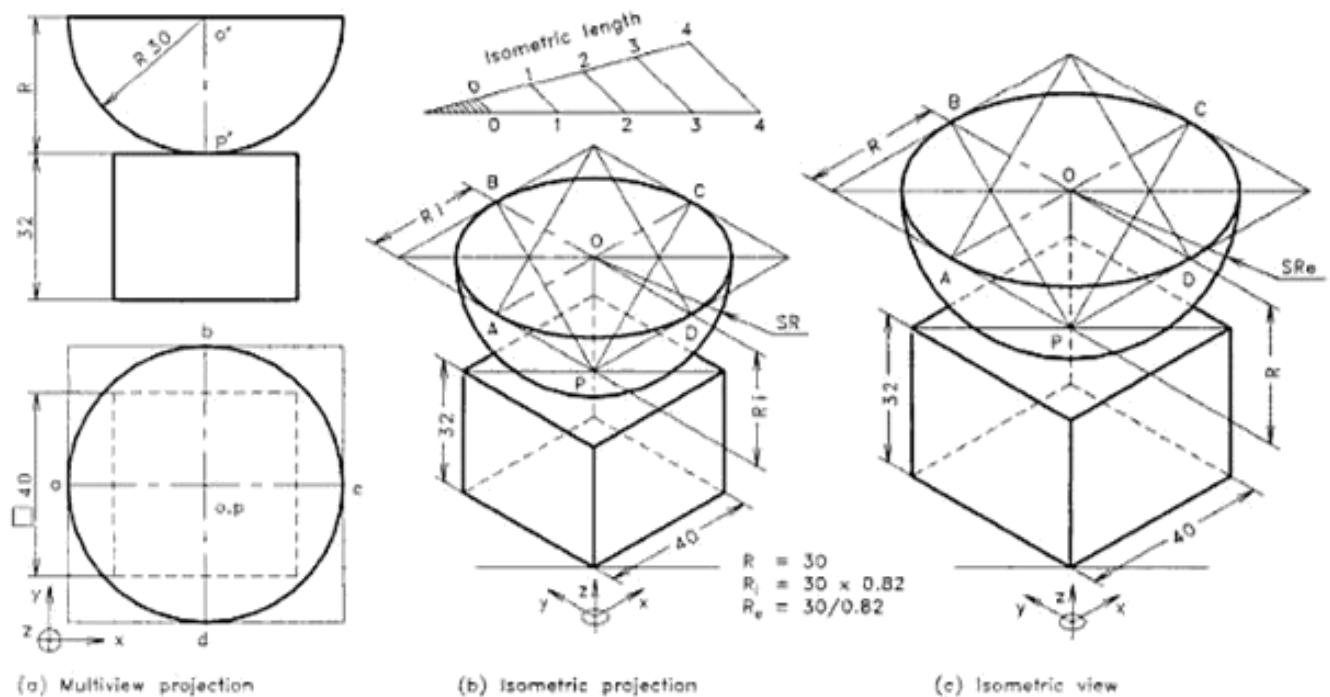

Fig. 16.27 A hemisphere on a square slab.

Urheberrechtlich geschütztes Material

Isometric View of a Hemisphere Resting on a Slab

In the preparation of isometric view of an object, the foreshortening of the isometric axes is ignored and the true length of the edges of the object are used directly for drawing. As a result, the isometric view obtained will be 22.5% larger in size. Similarly, if the isometric view of the hemisphere is drawn, the view obtained should be 22.5% larger than the given sphere itself [Fig. 16.27(c)]. So, the radius of the hemisphere in the isometric view should be enlarged to 22%, i.e. SR_e is equal to $1.225 \times R$, which is half the major axis of the ellipse representing the top circular plane. As the dimensions along the isometric axes are not foreshortened, the line joining the centre of the hemisphere to the point of contact of the spherical surface with the top of the slab $o'p'$ is also not foreshortened. Hence, $o'p' = OP = R$.

Hence, by the above explanations it is clear that:

1. For an isometric projection, all dimensions along xyz directions are foreshortened to 82% but the radius for the spherical surface should not be reduced.
2. For an isometric view, all dimensions along xyz directions are directly used but the radius for the spherical surface should be enlarged to 122.5%.

Example 16.14

A hemisphere of radius 30 mm is placed centrally on a square slab of side 40 mm and thickness 32 mm so that the flat circular surface is on the top. Draw the isometric projection and view of the solids in the given position.

Refer to Fig. 16.27.

1. Draw the multiview projection of the slab and hemisphere in the given position and enclose the circle in a square.
2. Construct the isometric scale and draw the isometric projection of the slab using isometric (82%) lengths.
3. Also draw the isometric view of the slab using the given dimensions directly.
4. To draw the isometric projection of the hemisphere, (b) locate the centre P of the top face of the isometric projection of the slab and draw a vertical line $OP = R$, i.e. the isometric length of $o'p'$ (30×0.82 mm). With centre O, draw the isometric square (rhombus) and construct the isocircle (ellipse) of radius R_i inside as shown in the figure. Construct a semicircle of radius equal to half the major axis of the ellipse (SR) at centre O to represent the spherical surface of the hemisphere. Note that the circle is not passing through the point P.

5. To draw the isometric view of the hemisphere, (c) locate the centre P of the top face of the isometric view of the slab and draw a vertical line $OP = R$, i.e. the length of $o'p'$ (30 mm). With centre O, draw the isometric square (rhombus) and construct the isocircle (ellipse) of radius R inside as shown in figure. Construct a semicircle of radius equal to half the major axis of the ellipse ($SR_e = 30/0.82$) at centre O to represent the spherical surface of the hemisphere. Note that here also the circle is not passing through the point P.
6. Finish the view and print the given dimensions to complete the drawing.

Example 16.15

A sphere of 18 mm radius is placed centrally over a hexagonal slab of side length 24 mm and thickness 25 mm. Draw isometric view of the combination.

Refer to Fig. 16.28.

1. Draw the multiview projection of the hexagonal slab and sphere in the given position. Enclose the hexagon in a square.
2. Construct the isometric view of the hexagonal slab using the given dimensions directly as shown.
3. To draw the isometric view of the sphere, locate the centre P of the top face of the isometric view of the slab (centre of line 1-4) and draw a vertical line $OP = R$, i.e. the length of $o'p'$ (18 mm). Construct a circle of radius $SR_e = 18/0.82$ mm at centre O to represent the surface of the sphere.
4. Finish the view and print the given dimensions to complete the drawing.

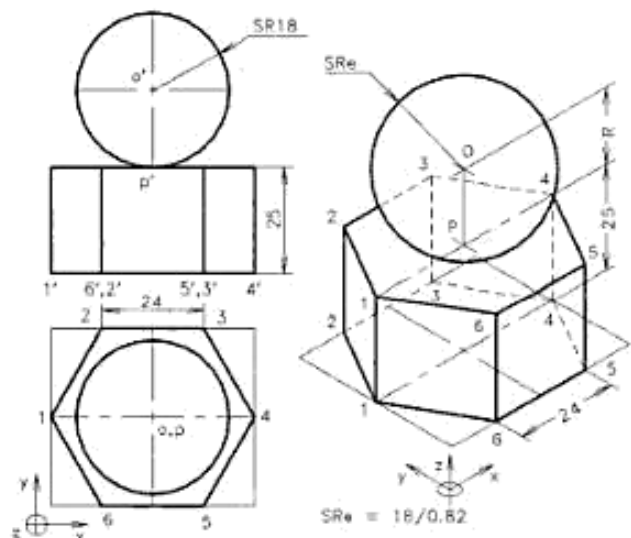

Fig. 16.28 Isometric view .

Urheberrechtlich geschütztes Material

16.9 OBJECTS

Simple engineering objects can be very clearly described by isometric projection or view. Since the preparation of isometric view is simpler, generally that is preferred for engineering objects. The hidden lines are shown only if they are necessary. The following examples describe the procedure of drawing and they are self-explanatory. The construction lines are retained in order to understand the method of drawing. Since the problems are given as multiview projection, the student has to develop the capacity to read and visualize the shape of object, before starting the drawing. The location of the origin of the isometric axes has to be fixed in such a way that it brings out maximum information of the object.

Example 16.16

Draw the isometric view of the block shown in Fig. 16.29(a).

Refer to Fig. 16.29(b).

1. Locate the origin of the isometric axes on the left bottom corner of the top view and draw the isometric view of the box containing the block.
2. Mark the corners of the block relative to the edges of the box as shown in the figure.
3. Finish the view and print the given dimensions to complete the drawing.

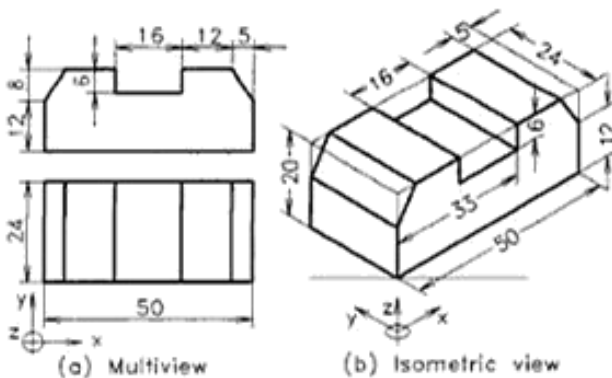

Fig. 16.29 A block.

Example 16.17

Draw the isometric view of the bracket shown in Fig. 16.30(a).

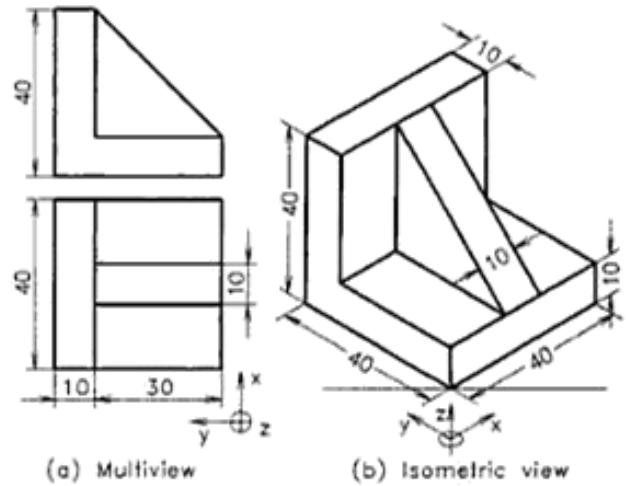

Fig. 16.30 A bracket.

Refer to Fig. 16.30(b).

1. Locate the origin of the isometric axes on the right bottom corner of the top view in order to get clear view of the web on the right isometric plane.
2. Draw isometric view of the bracket considering it as three slabs such as a square horizontal slab, a rectangular vertical slab and a vertical triangular slab joined together.
3. Finish the view and print the given dimensions to complete the drawing.

Example 16.18

Draw the isometric view of the machine part shown in Fig. 16.31(a).

Refer to Fig. 16.31(b).

Draw isometric view of the machine part considering it as three slabs such as a rectangular horizontal slab with a slot, a rectangular vertical slab and a semicircular vertical slab joined together.

Example 16.19

Draw the isometric view of the block shown in Fig. 16.32(a) and need not dimension.

Refer to Fig. 16.32(b).

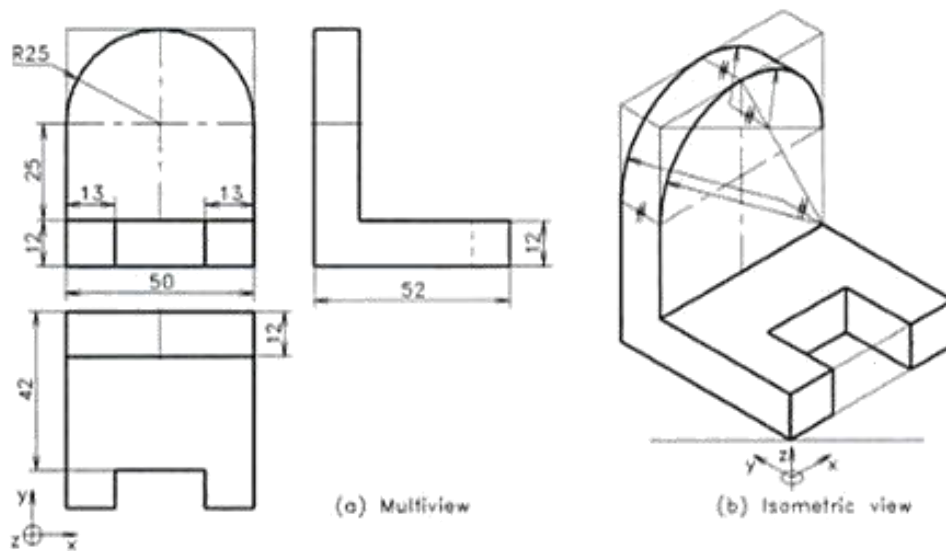

Fig. 16.31 A machine part.

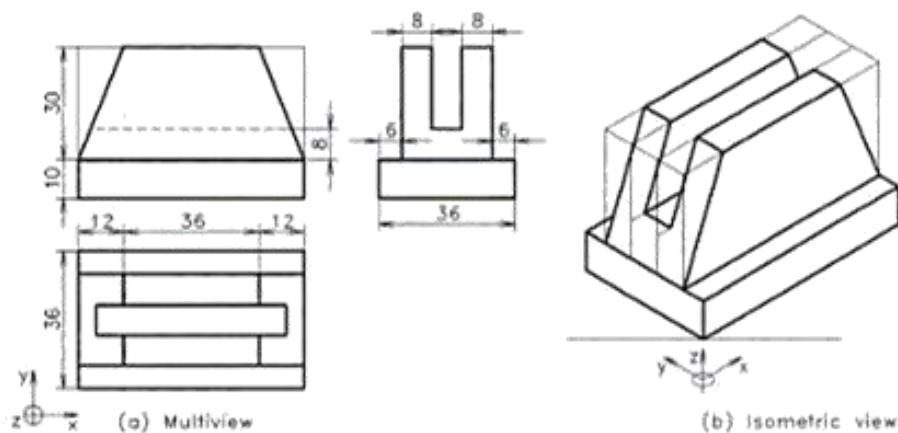

Fig. 16.32 A block.

Tools to solve isometric projection problems

1. The isometric axes in x and y directions are drawn at 30° inclination to horizontal and z axis in vertical direction.
2. In isometric projection, the dimensions measured from multiview along xyz directions should be foreshortened and marked in the corresponding isometric axes.
3. In isometric view, the dimensions measured from multiview along xyz directions are marked directly in the corresponding isometric axes.
4. The radius of arc representing a spherical surface should not be foreshortened in isometric projection, whereas in isometric view it has to be enlarged to 122.5%.
5. Box method or coordinate method can be used interchangeably in isometric drawings. For pyramids, cones and sectioned solids coordinate method is found more fast to reach solution whereas the box method is better for solids in inclined position or objects have intricate shapes.
6. A circle is seen as ellipse and it can be drawn by four centre method.
7. If the origin of axes is kept at the left bottom corner of the top view; the front, top and left side views are seen on right, top and left isometric planes respectively. Similarly, If the origin of axes is kept at the right bottom corner of the top view; the front, top and right side views are seen on left, top and right isometric planes respectively.

EXERCISES

SECTION A

(# Problems similar to workedout examples)

Solids

1. Draw the isometric projection of a rectangular prism of side of base 40 mm \times 24 mm and height 50 mm, resting upon its base on HP and the 40 mm long edges are parallel to VP. (#)
2. Draw isometric view of a pentagonal prism of 52 mm height and side 26 mm long, lying on HP with the axis perpendicular to VP. Select the origin of the isometric axes suitable to get the front view on the left isometric plane. (#)
3. Draw isometric view of a cylinder of 60 mm height and diameter 44 mm, lying on one of its generators on HP with the axis perpendicular to VP. Select the origin of the isometric axes suitable to get the front view on the right isometric plane. (#)
4. Draw the isometric projection of a hexagonal prism of side of base 26 mm and height 64 mm, resting upon its base on HP and a rectangular face is parallel to VP. (#)
5. A pentagonal pyramid of height 60 mm and side 28 mm is resting on HP, keeping its axis vertical and one edge of the base parallel to VP. Draw isometric view of the solid. (#)
6. A cone of height 70 mm and diameter 52 mm is resting on HP, keeping its axis vertical. Draw isometric view of the solid. (#)
7. A frustum of a cone of base diameter 56 mm, top diameter 32 mm, and height 52 mm is resting upon its base on HP. Draw the isometric projection of the frustum. (#)
8. A square pyramid, edge of base 52 mm and axis 64 mm long, is lying on one of its triangular faces upon HP and its axis parallel to VP. Draw the isometric view of the given pyramid showing the base. (#)
9. A pentagonal pyramid, edge of base 30 mm and axis 60 mm long, is lying on one of its triangular faces upon HP and its axis parallel to VP. Draw the isometric view of the given pyramid without showing the base surface.

Sectioned solids

10. A hexagonal prism of side of base 26 mm and height 64 mm is resting on its base upon HP, keeping one base edge parallel and nearer to VP. The prism is cut by a section plane, 30° inclined to HP and passing through a

point on the axis, 40 mm above the base. Draw isometric projection of the prism showing the sectioned surface. (#)

11. A pentagonal prism of side of base 24 mm and length 64 mm is resting on one of its rectangular faces upon HP, keeping the base parallel to VP. The prism is cut by a vertical section plane 30° inclined to VP and passing through the mid-point on the axis. Draw isometric view of the prism showing the sectioned surface. (#)
12. A hexagonal pyramid of side of base 26 mm and height 64 mm is resting on its base upon HP, keeping two base edges parallel to VP. The pyramid is cut by a section plane, 30° inclined to HP and passing through the midpoint of the axis. Draw isometric view of pyramid showing the section. (#)
13. A cylinder of diameter 56 mm base and 80 mm height is resting upon its base on HP. A section plane of 45° inclination to HP bisects the axis of the cylinder. Draw the isometric view of the cylinder showing the sectioned surface. (#)
14. A cylinder of diameter 50 mm base and 70 mm height is resting upon its base on HP. A section plane of 60° inclination to HP cuts the axis of the cylinder at a height of 55 mm from the base. Draw the isometric view of the cylinder showing the sectioned surface.

Combination of solids

15. A hexagonal pyramid of base edge 20 mm and height 50 mm is surmounted over a square slab of 50 mm side and 30 mm thickness on HP so that one side of the square and one base edge of the pyramid are parallel to VP. Draw isometric view of the combination. (#)
16. A hemisphere of radius 32 mm is placed centrally on a square slab of side 36 mm and thickness 30 mm so that the flat circular surface is on the top. Draw the isometric projection and view of the solids in the given position. (#)
17. A sphere of 20 mm radius is placed centrally over a pentagonal slab of side length 30 mm and thickness 36 mm. Draw isometric view of the combination. (#)

Objects

18. Draw isometric view of the block shown in Fig. 16.33. (#)
19. Orthographic views of a block are shown in Fig. 16.34. Draw the isometric view. (#)

Urheberrechtlich geschütztes Material

47. Orthographic view of a V-block is shown in Fig. 16.45. Draw the isometric view.

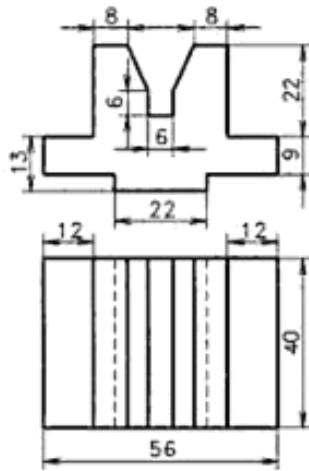

Fig. 16.45

49. A rod support is shown in Fig. 16.47. Draw its isometric view.

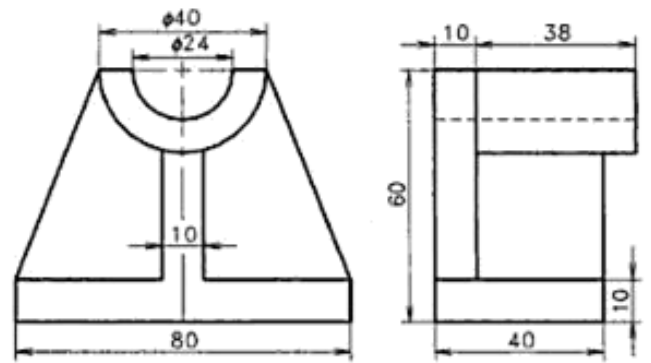

Fig. 16.47

48. A cast iron block is shown in front and side views. Draw its isometric view. Refer Fig. 16.46.

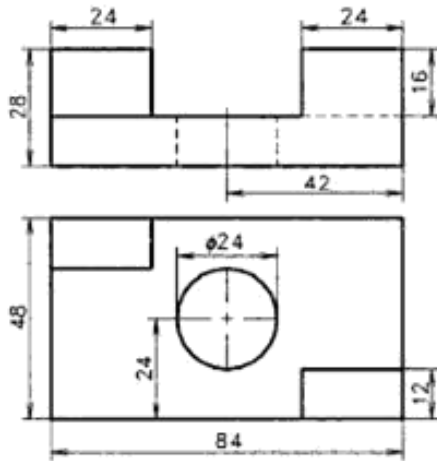

Fig. 16.46

50. Multiview projection of a crank is shown in Fig. 16.48. Draw the isometric view of the crank.

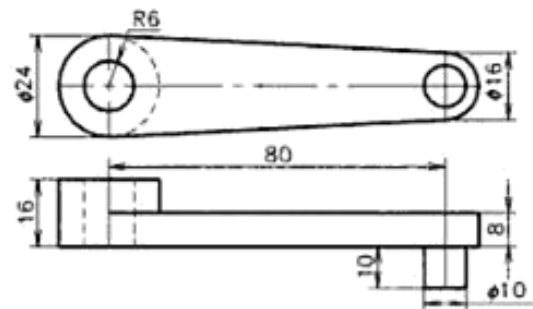

Fig. 16.48

Urheberrechtlich geschütztes Material

Perspective Projection

Perspective projection is a method of graphic representation of an object on a single plane called *picture plane* as seen by an observer stationed at a particular position relative to the object. As the object is placed behind the picture plane and the observer is stationed in front of the picture plane, visual rays from the eye of the observer to the object are cut by the picture plane. The visual rays locate the position of the object on the picture plane. This type of projection is called *perspective projection*. This is also known as *scenographic projection* or *convergent projection*.

18.1 PRINCIPLE OF PERSPECTIVE PROJECTION

In perspective projection, the projectors or visual rays intersect at a common point known as *station point*. A perspective projection of a street with posts holding lights, as viewed by an observer from a station point, is shown in Fig. 18.1(a). The observer sees the object through a transparent vertical plane called *picture plane*. The view obtained on the picture plane is shown in Fig. 18.1(b). In this view, the true shape and size of the street will not be seen as such, since the object is viewed from a station point to which the visual rays converge. On the picture plane the same size objects become smaller as it is going away from the observer. Finally, they become small as a point on the horizon and vanish.

Perspective projection is theoretically very similar to the optical system in photography. It is extensively employed by architects to show the appearance of a building or by an artist-draftsman in the preparation of illustrations of huge machinery.

18.2 NOMENCLATURE OF PERSPECTIVE PROJECTION

The elements of perspective projection are shown in Fig. 18.2. The important terms used in perspective projection are defined below:

1. *Ground Plane (GP)*: This is the plane on which the object is assumed to be placed.
2. *Auxiliary Ground Plane*: This is any plane parallel to the ground plane (not shown).
3. *Station Point (SP)*: This is the position of the observer's eye, from where the object is viewed.
4. *Picture Plane (PP)*: This is the transparent vertical plane positioned in between the station point and the object to be viewed. Perspective view is formed on this vertical plane.
5. *Ground Line (GL)*: This is the line of intersection of the picture plane with the ground plane.

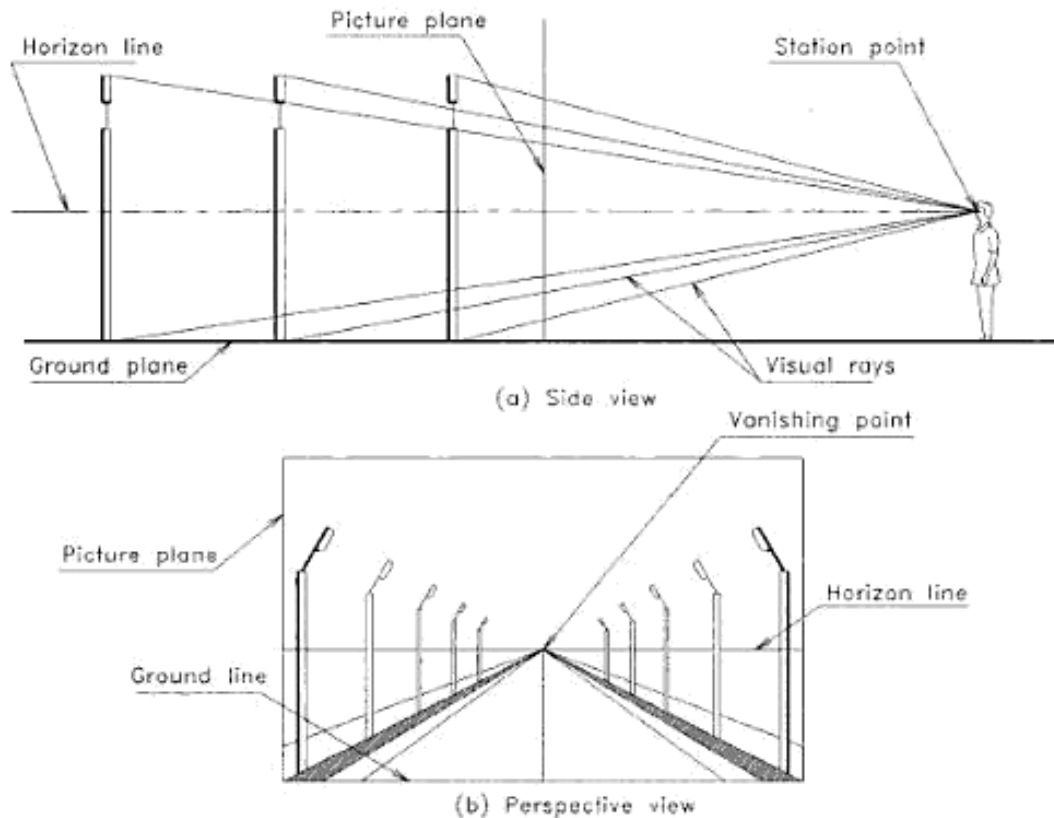

Fig. 18.1 View of a street.

6. **Auxiliary Ground Line:** This is the line of intersection of the picture plane with the auxiliary ground plane (not shown).
7. **Horizon Plane:** This is an imaginary horizontal plane perpendicular to the picture plane and passing through the station point. This plane lies at the level of the observer.
8. **Horizon Line (HL):** This is the line of intersection of the horizon plane with the picture plane. This plane is parallel to the ground line.
9. **Axis of Vision (AV):** This is the line drawn perpendicular to the picture plane and passing through the station point. The axis of vision is also called the *line of sight* or *perpendicular axis*.
10. **Centre of Vision (CV):** This is the point through which the axis of vision pierces the picture plane. This is also the point of intersection of the horizon line with the axis of vision.
11. **Central Plane (CP):** This is an imaginary plane perpendicular to both the ground plane and the

picture plane. It passes through the centre of vision and the station point, while containing the axis of vision.

12. **Visual Rays (VR):** These are imaginary lines or projectors, joining the station point to the various points on the object. These rays converge to a point.

18.3 CLASSIFICATION OF PERSPECTIVE VIEWS

Perspective views are classified into three categories.

1. Parallel perspective or single point perspective.
2. Angular perspective or two point perspective.
3. Oblique perspective or three point perspective.

The perspective views are based on the relative positions of the object with respect to the picture plane. All the three types of perspectives are shown in Fig. 18.3.

Parallel Perspective (Single Point)

If the principal face of the object viewed is parallel to the picture plane, the perspective view formed is called *parallel*

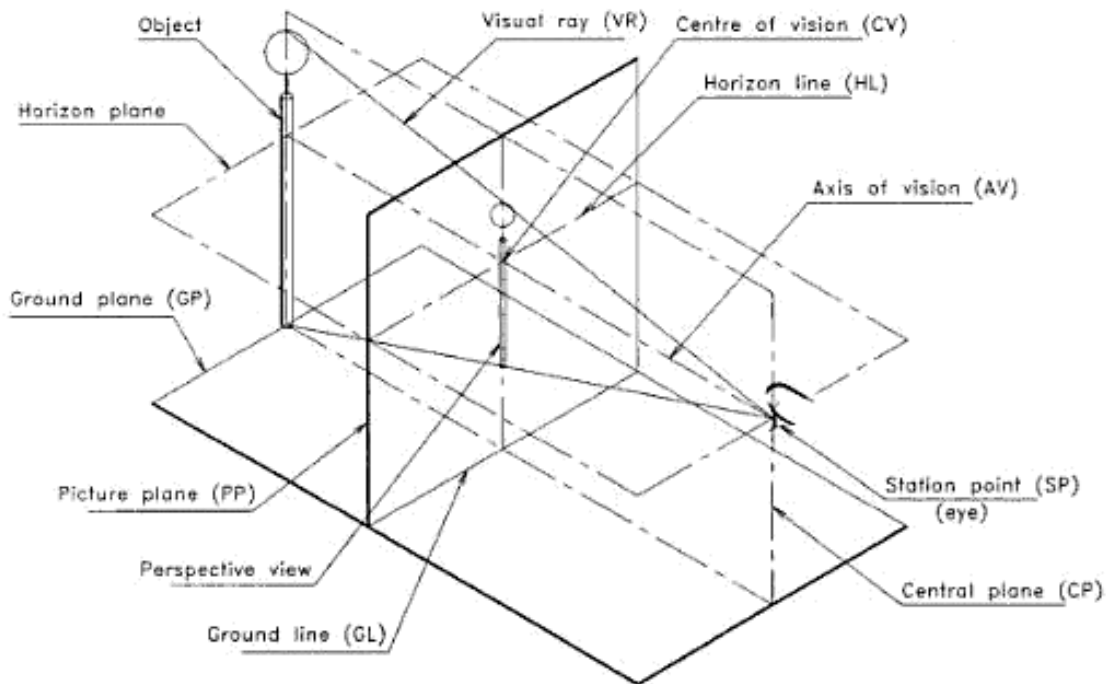

Fig. 18.2 Nomenclature of perspective projection.

perspective. Such a perspective view is shown in Fig. 18.3(a). In parallel perspective views, the horizontal lines receding the object converge to a single point called *vanishing point (VP)*. But the vertical and horizontal lines on the principal face and the faces parallel to it on the object do not converge, if these lines are parallel to the picture plane. Because the lines on the faces parallel to the picture plane, do not converge to a point and the horizontal lines receding the object coverage to a single vanishing point, the perspective projection obtained is called *parallel or single point perspective*. Single point perspective projection is generally used to show the interior details of rooms, interior features of various components, etc.

Angular Perspective (Two Point)

If the two principal faces of the object viewed are inclined to the picture plane, that perspective view formed is called *angular perspective*. Such a perspective view is shown in Fig. 18.3 (b). In angular perspective views, all the horizontal lines converge to two different points called *vanishing point left (VPL)* and *vanishing point right (VPR)*. But the vertical lines remain vertical. Because the two principal faces are inclined to the picture plane and all the horizontal lines on the object converge to two different vanishing points, the perspective view obtained is called *angular or two point perspective*. Two point perspective projection is the most

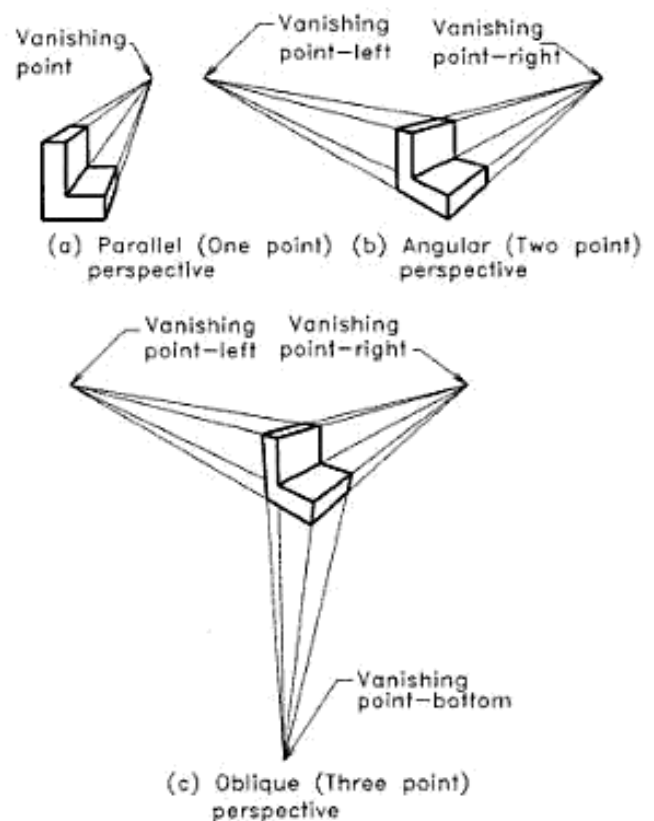

Fig. 18.3 Perspective projections.

Urheberrechtlich geschütztes Material

generally used one to present the pictorial views of long and wide objects like buildings, structures, machines, etc.

Oblique Perspective (Three point)

If all the three mutually perpendicular principal faces of the object viewed are inclined to the picture plane, the perspective view formed is called *oblique perspective*. Such a perspective view is shown in Fig. 18.3(c). In oblique perspective views, all the horizontal lines converge to two different points called *vanishing point left (VPL)* and *vanishing point right (VPR)* and all the vertical lines converge to a third vanishing point located either above or below the horizon line. Because all the three principal faces are inclined to the picture plane and all the horizontal and vertical lines on the object converge to three different vanishing points, the perspective view obtained is called *oblique or three point perspective*.

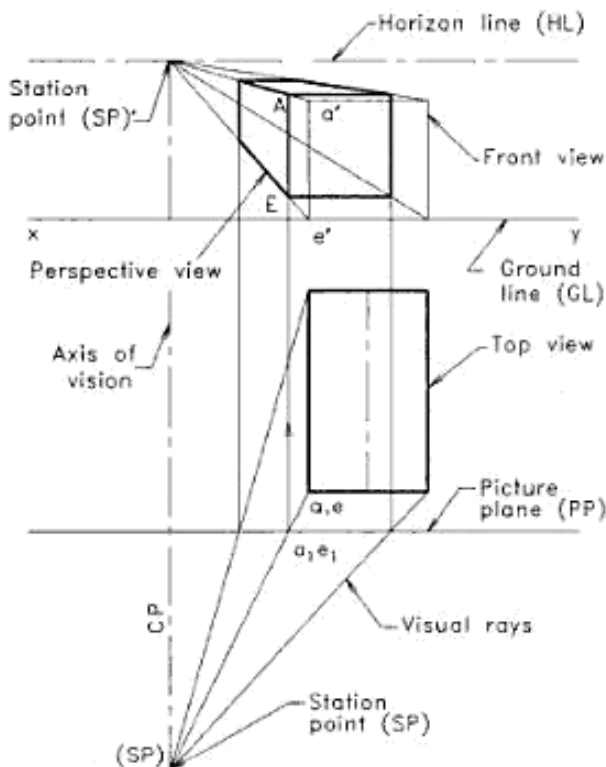

Fig. 18.4 Elements of perspective projection (visual ray method—using front view).

Three point perspective projection may be used to draw pictorial views of huge and tall objects like tall buildings, towers, structures, etc. If the station point is nearby the ground plane, the vertical lines will vanish at a point above the horizon line. If the station point is located above the

object, all the vertical lines will vanish to a point below the horizon line.

18.4 METHODS OF DRAWING PERSPECTIVE VIEWS

Perspective view of an object can be drawn by following any one of the methods:

1. Visual ray method.
 - (a) Using top and front views.
 - (b) Using top and side views.
2. Vanishing point method.

To obtain a perspective view (parallel, angular or oblique), by the visual ray or vanishing point method, there are different approaches in practice. Here, one among the simplest, which is obeying the first angle projection, is explained.

To start the drawing of a perspective view, the following data are the basic requirements.

1. The top and front or side views of the object.
2. The location of the station point SP (the point of sight or camera position) in relation to the object, in three dimensions.
3. The location of the picture plane PP in relation to the object, in three dimensions.

In visual ray method, the points forming the perspective view are obtained by drawing visual rays from the station points (the point of sight) SP and SP' or SP'' to the top and front or side views respectively of the object.

In vanishing point method, the vanishing point or points are to be located initially. Vanishing points are the imaginary points located at infinite distance from the observer and they exist on the horizon line. The parallel edges, which are perpendicular or inclined to the picture plane, will converge to a point, if they are extended to infinity. Following the principle, the parallel edges going away from the picture plane are drawn converging to the vanishing point or points, to get the perspective view.

18.5 VISUAL RAY METHOD, USING TOP AND FRONT VIEWS

After obtaining or fixing the required data, the top and front views of the object are drawn following the first angle projection theory as shown in Fig. 18.4. Here, the top view, the picture plane PP, the plan of station point SP and the visual rays are drawn initially below the ground (xy) line GL. The front view, horizon line HL, elevation of the station point SP' and the visual rays are drawn next. This completes the drawing of elements of perspective projection. In Fig. 18.4, a square prism is lying on ground with the square

face parallel to PP. To get the perspective view seen from SP, draw vertical projectors through the crossing points of visual rays on picture plane PP. The points of intersection of these vertical projectors on the visual rays drawn in the front view give the perspective view. For example, corners A and E on the perspective view are obtained by drawing vertical projectors through a_1 and e_1 on PP, and extending them to intersect on visual rays drawn to a' and e' respectively.

It is to be noted that the top and perspective views are finished using thick lines, while all the remaining lines are left as thin. The corners of the perspective view may be marked with capital letters, as did for other pictorial views. Dimensions are not usually marked on perspective views but the elements used for perspective view drawing should be dimensioned fully by a student without failure.

Parallel Perspective by Visual Ray Method

In parallel perspective, the principal face of the object is kept parallel to the picture plane (PP). If a face is kept touching the PP, that face will be seen in its true size and shape. As the face goes behind the PP, the view of it will be reduced in size, but will keep the true shape i.e. a circle or square will retain its shape, if the plane containing it is parallel to PP. Figure 18.5 shows the parallel perspective of a square prism. Here, the front face is slightly behind the PP, hence that face is seen to be slightly reduced in size, but keeps the square shape. Similarly, Fig. 18.6 shows the parallel perspective of a horizontal pentagonal prism. Here the prism is touching the PP hence, that face is seen as the true size and shape. The back side face is also a regular pentagon but of smaller size because it is parallel to and behind the PP.

If there are curved or non-parallel edges on the object and are not parallel to picture plane, the perspective of such shapes can be drawn by enclosing them in rectangles or boxes as did for other pictorial views. Fig. 18.7 shows the parallel perspective of a circle contained in HP. The intermediate points are located in relation to the edges of the rectangle or box.

Example 18.1

A square prism of 30 cm side and 50 cm length is lying on the ground plane on one of its rectangular faces, in such a way that one of its square faces is parallel to and 10 cm behind the picture plane. The station point is located 60 cm in front of the picture plane and 40 cm above the ground plane. The central plane is 50 cm away from the axis of the prism towards the left. Draw the perspective view of the prism.

Refer to Fig. 18.5.

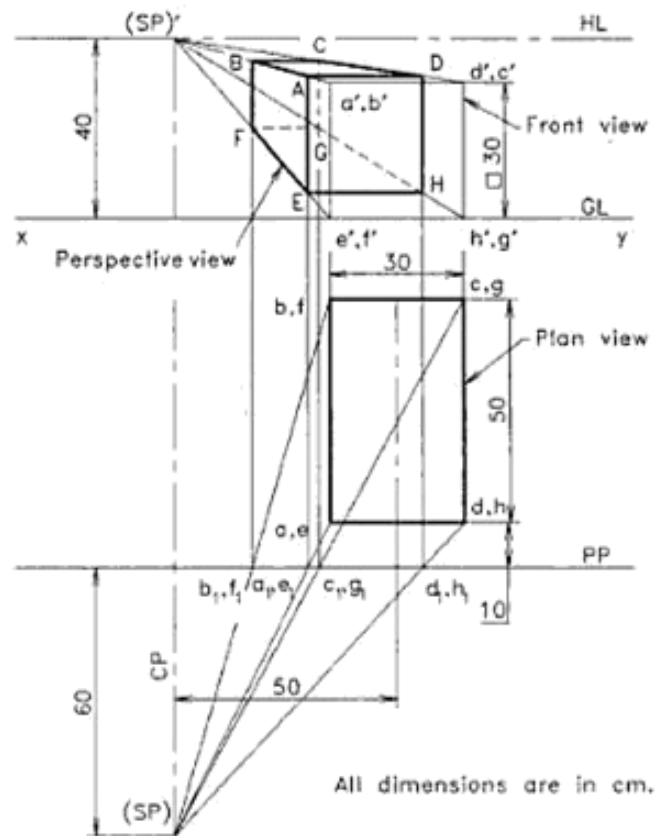

Fig. 18.5 Parallel perspective (visual ray method—using front view).

1. Draw the xy (GL) line and construct the top and front views of the prism in the given position following the orthographic projection rules as shown in figure.
2. Mark the top view of the picture plane (PP) and the front view of the horizon plane HL at a distance of 40 cm above the xy line (GL). Locate the central plane (CP) 50 cm away from the axis of the prism, towards the left side. Locate the top view of the station point (SP) at a distance of 60 cm in front of the PP and on the CP. Also mark the front view of the station point (SP)' on the HL.
3. Draw visual rays from (SP) to the various corners of the top view of the prism, piercing the PP at a_1 , b_1 , c_1 , etc. Also draw the visual rays from (SP)' to all corners of the front view.
4. Draw vertical lines upwards from the points a_1 , b_1 , c_1 , etc. to intersect the corresponding visual rays

drawn from a' , b' , c' , etc. Join the points to get the required perspective ABCDEFGH.

- Convert the top and perspective views to proper line types and print the given dimensions.

Angular Perspective by Visual Ray Method

In angular perspective projection, two principal faces (front face and one side face) of the object are kept at an angle, usually 30° or 60° , to the PP. As is done in the parallel perspective, the top view, front view and the perspective elements are also drawn for the angular perspective. The visual rays are drawn from (SP) to the top view corners and from (SP)' to the front view corners. The points on the perspective view are obtained by inserting verticals from the points of intersection of visual rays with PP, to meet the visual rays drawn to the front view.

Example 18.2

Draw the perspective view of a rectangular prism of $80\text{ cm} \times 48\text{ cm} \times 36\text{ cm}$ size, lying on its $80\text{ cm} \times 48\text{ cm}$ rectangular face on the ground plane, with a vertical edge touching the picture plane and the end faces inclined at 60° with the picture plane. The station point is 80 cm in front of the picture plane, 64 cm above the ground plane and it lies in a central plane, which passes through the centre of the prism.

Refer to Fig. 18.6.

- Draw the top view, front view and the perspective elements of the prism as per the given data.
- Draw visual rays from (SP) to the corners of the top view and from (SP)' to the front view.
- Insert verticals through the visual ray piercing points on PP, to meet the visual rays drawn to the front view. For example, to get the point B on the perspective view, join (SP) to b in the top view to cross PP and at b_1 . Insert a vertical line from b_1 to meet the visual ray to b' (SP)' at B. Similarly obtain A, C, etc.
- Convert the top, side and perspective views to proper line types and print the given dimensions.

18.9 ANGULAR PERSPECTIVE BY VANISHING POINT METHOD

In vanishing point method, the vanishing point or points are to be located on picture plane. Vanishing points are the imaginary points located at infinite distance from the observer. In perspective drawings, if a visual ray is drawn from a station point to an infinite distant object, the point of

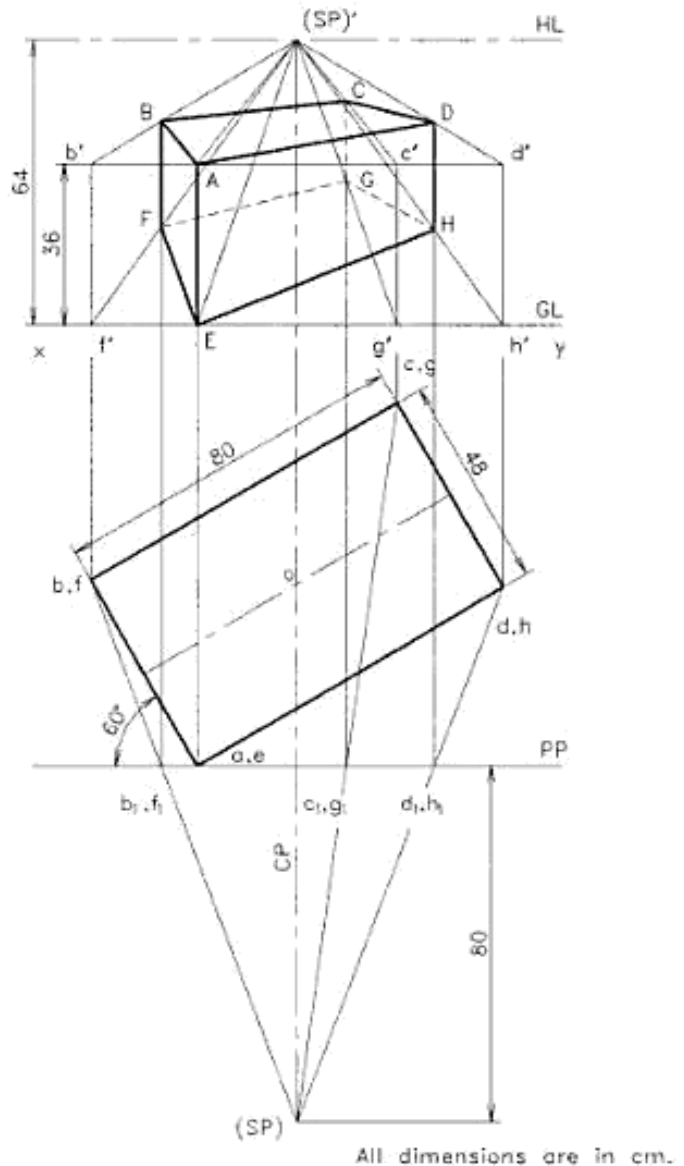

Fig. 18.6 Angular perspective (visual ray method-using front view).

piercing of that ray through the picture plane (PP) is referred to as the vanishing point on the PP.

Three top views of a horizontal line PQ, inclined at θ degrees to the picture plane, located in three different positions with respect to the station point, are shown in Fig. 18.7. When the top view pq is in position (i), the length of the line obtained on PP is p_1q_1 . As the top view moves towards the left side, without changing the inclination θ , the length of the line obtained on PP reduces to p_2q_2 and is shown

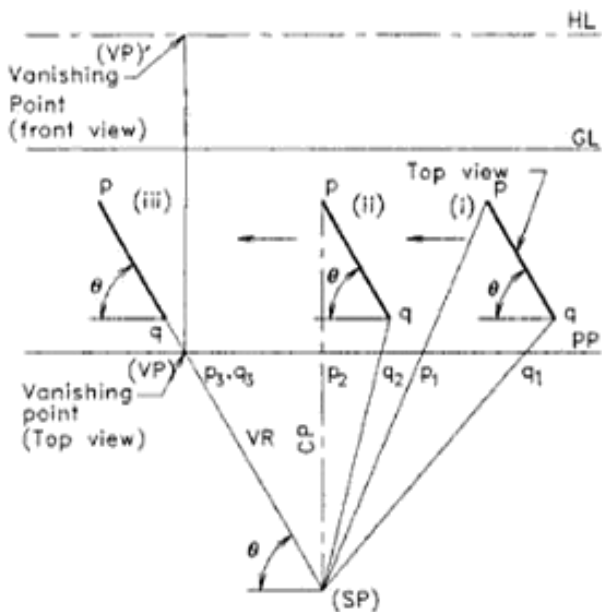

Fig. 18.7 Vanishing point of a line inclined to the picture plane.

in position (ii). When it moves further towards the left, the length of the line on PP gradually reduces and finally, it becomes zero. Hence P_3 coincides with q_3 . This point is called the *top view of the vanishing point* (VP) of the line PQ on PP, for the given conditions. It may be noted that the inclination of the visual rays, drawn to the vanishing point, has the same inclination as that of the line pq . The front view of the vanishing point $(VP)''$ lies on the horizon line (HL). Hence, the point of intersection of the vertical line through VP and the horizon line HL is $(VP)'$.

To draw the angular perspective of an object, the top view and the elements of perspective are drawn first. Then the vanishing points (VPL) and (VPR) are determined by the above principle. By considering the height of the object, rays are drawn to the two vanishing points. Vertical lines are drawn from the visual ray-crossing points on the PP, to intersect these rays for the points on the perspective view.

Example 18.3

A rectangular prism of dimensions $80\text{ cm} \times 48\text{ cm} \times 32\text{ cm}$ is lying on the ground in such a way that one of the largest faces is on the ground. A vertical edge is 10 cm behind PP and longer face containing that edge makes 30° inclination with PP. The station point is 80 cm in front of the PP, 60 cm above the ground and lies in a central plane which passes through the centre of the prism. Draw the perspective view by vanishing point method.

Refer to Fig. 18.8.

1. Draw the top view of picture plane PP, the top view of the prism at the given position and mark the station point (SP), as shown in the figure. Also draw the ground line GL at any convenient distance from PP and mark the horizon line HL.
2. Through (SP), draw lines parallel to the edges ad and ab of the top view of the prism, to intersect PP at (VPR) and (VPL) respectively. Draw vertical lines from (VPR) and (VPL) to intersect HL at $(VPR)'$ and $(VPL)'$ respectively, which are the front views of the vanishing points.
3. Since the edge ae is 10 cm behind the picture plane, produce the face $adeh$ to meet the PP at the point s, t . Draw a vertical line from the point s, t to intersect the ground line GL at T. Since the edge st is touching on PP, it will have the true length in the perspective view. Hence, mark $ST = 32\text{ cm}$, (the thickness of the prism) from the line GL as shown in the figure.
4. Join points S and T to $(VPR)'$ and drop a vertical line from point (a_1, e_1) to intersect these rays at A and E. Draw rays from points A and E to $(VPL)'$ and drop a vertical line from (b_1, f_1) to intersect these rays at B and F. Now ABFE is a face on the perspective view. Similarly find out points C, D, G and H and join these points to get the perspective view.
5. Draw the visible edges with thick lines and convert the hidden edges to short dashes, to complete the required view.
6. Finish the view and print the given dimensions as shown in the figure.

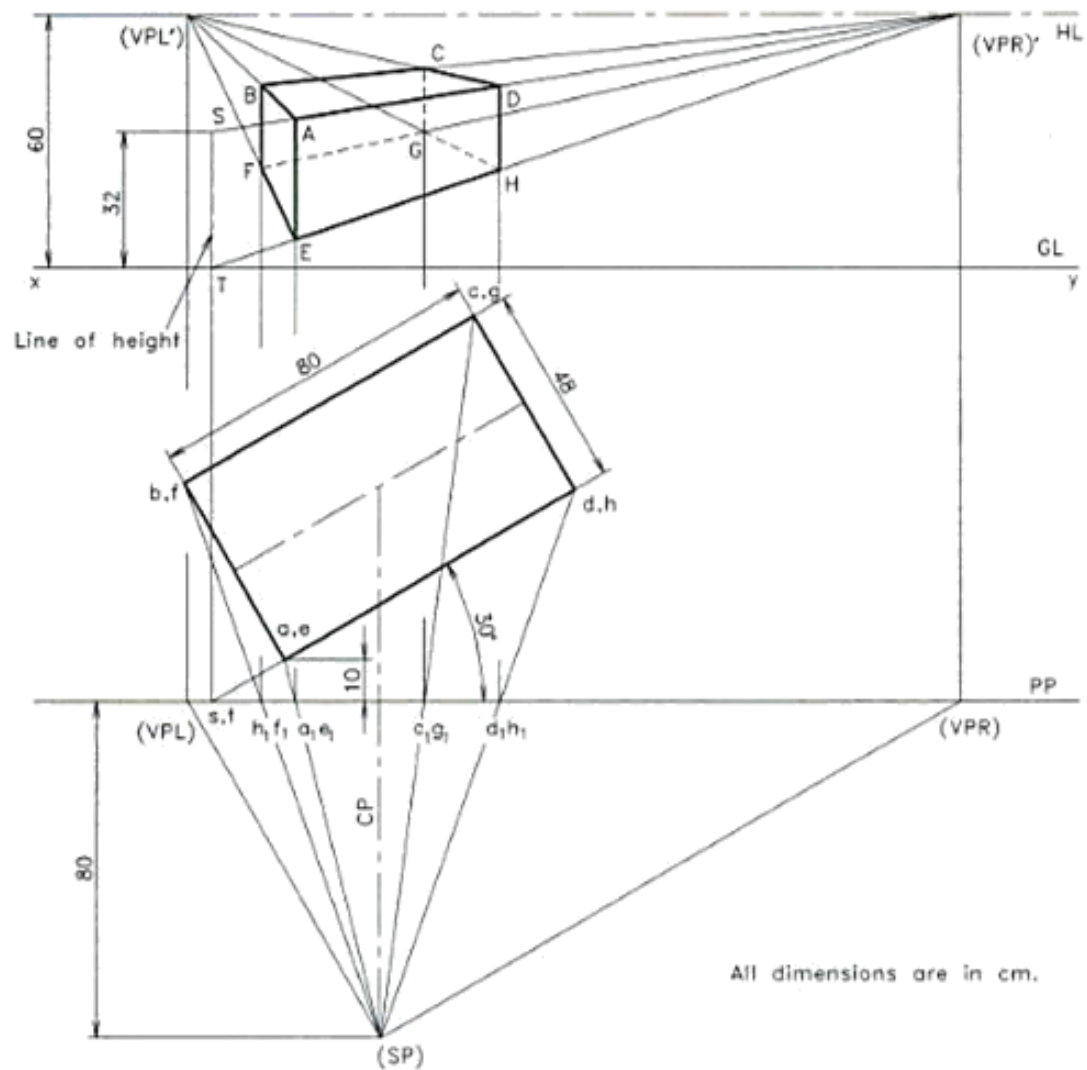

All dimensions are in cm.

Fig. 18.8 Angular perspective (vanishing point method).

EXERCISES

(# Problems similar to the workedout examples)

Visual ray method

1. A square prism of 32 cm side and 54 cm length is lying on the ground plane on one of its rectangular faces, in such a way that one of its square faces is parallel to and 12 cm behind the picture plane. The station point is located 60 cm in front of the picture plane and 48 cm above the ground plane. The central plane is 50 cm away from the axis of the prism towards the left. Draw the perspective view of the prism. (#)
2. Draw the perspective view of a hexagonal prism, 20 cm side and 40 cm long, lying on one of its rectangular faces on the ground plane. One of its pentagonal faces touches the picture plane and the station point is 60 cm in front of the picture plane, 28 cm above the ground plane and lies in the central plane, which is 70 cm to the left of the centre of the prism. (#)
3. Draw the perspective view of a rectangular prism of 70 cm × 44 cm × 32 cm size, lying on its 70 cm × 44 cm rectangular face on the ground plane, with a vertical edge touching the picture plane and the end faces inclined at 60° with the picture plane. The station point is 80 cm in front of the picture plane, 70 cm above the ground plane and it lies in a central plane, which passes through the centre of the prism. (#)

Urheberrechtlich geschütztes Material

Vanishing point method

4. A rectangular prism of dimensions 75 cm × 50 cm × 30 cm is lying on the ground in such a way that one of the largest faces is on the ground. A vertical edge is 12 cm behind PP and longer face containing that edge makes 30° inclination with PP. The station point is 90 cm in front of the PP, 64 cm above the ground and lies in a central plane which passes through the centre of the prism. Draw the perspective view by vanishing point method. (#)
5. A circular lamina of 60 cm diameter is kept vertical on the ground plane and is inclined 45° to the picture plane. The station point is positioned 80 cm in front of the picture plane and 82 cm above the ground plane. The central plane containing the station point passes 40 cm away to the right of the centre of the circular lamina. Draw the perspective view of the lamina, if its periphery is in contact with the picture plane. Employ vanishing point method. (#)
6. A vertical rectangular prism of dimensions 60 cm × 50 cm × 30 cm is standing on the ground on one of the end faces such that the picture plane passes through the prism. A vertical edge of 60 cm length is 12 cm in front of PP and the 60 cm × 30 cm face containing that edge makes 30° inclination with PP. The station point is 140 cm in front of the PP, 90 cm above the ground and lies in a central plane which passes through the corner in front of PP. Draw the perspective view by vanishing point method. (#)

Urheberrechtlich geschütztes Material

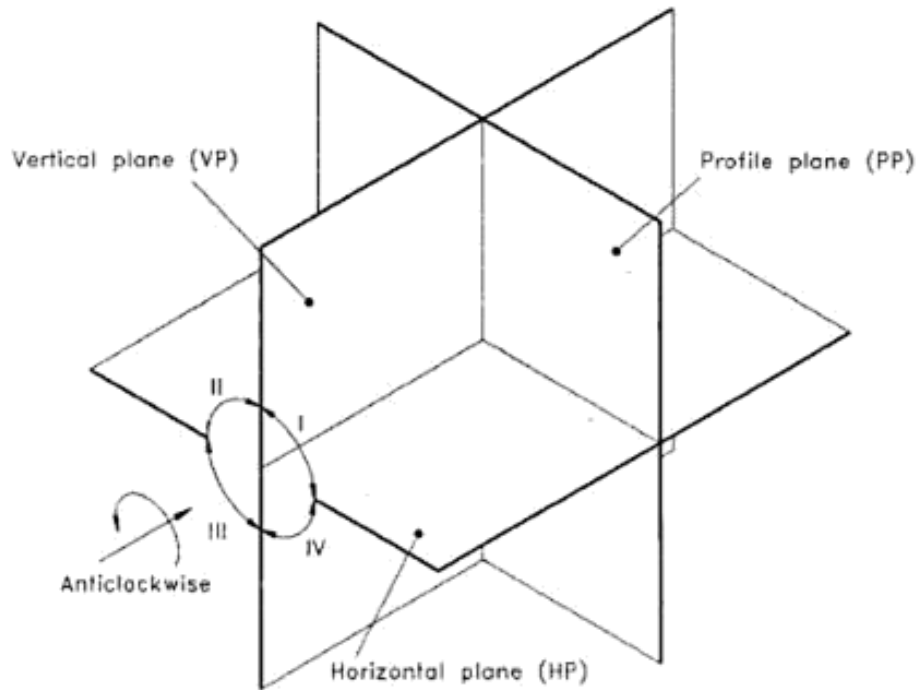

Figure 19.1 Planes of projection showing octants (anticlockwise system).

19.2 FIRST ANGLE PROJECTION AND THE LOCATIONS OF THE THREE VIEWS

In first angle projection, the object is assumed to be positioned in the first quadrant as shown in Figure 19.2. Here, the object is placed in such a way that its main faces are parallel to the principal planes and hence the projections of these faces on the principal planes will have the true shape and size.

The three views formed on the principal planes are described below:

1. Front view: The view of the object formed on the vertical plane (VP) or frontal plane, when looked orthogonally at the object in the direction marked FRONT, is called *front view*. Here, the VP is behind the object. Thus, the object is in between the plane of projection and the eye. This is indicated by

EYE > OBJECT > PLANE

2. Top view: The view of the object formed on the horizontal plane (HP) when looked orthogonally at the object from the top in the direction marked TOP, is called *top view*. Here, the horizontal plane is below the object. Thus, the object is in between the plane of projection and the eye. This is indicated by

EYE > OBJECT > PLANE

3. Left side view: The view of the object formed on the profile plane (PP), when looked orthogonally at the object in the direction marked LEFT-HAND SIDE, is called *left side view*. Here, the profile plane is behind the object. Thus, the object is in between the eye and the plane of projection. This is also indicated by

EYE > OBJECT > PLANE

To bring the three views into a single plane, revolve the coordinate planes through 90° , as indicated by the arrows. The complete layout of the three views of the object, after rabation, will be as shown in Figure 19.3.

19.3 THIRD ANGLE PROJECTION AND THE LOCATIONS OF THE THREE VIEWS

In third angle projection, the object is assumed to be positioned in the third quadrant. Here, the object is placed in such a way that its main faces are parallel to the principal planes and hence the projections of these faces on the principal planes will have the true shape and size.

The complete layout of the three views of an object in third angle projection is as shown in Figure 19.4.

Urheberrechtlich geschütztes Material

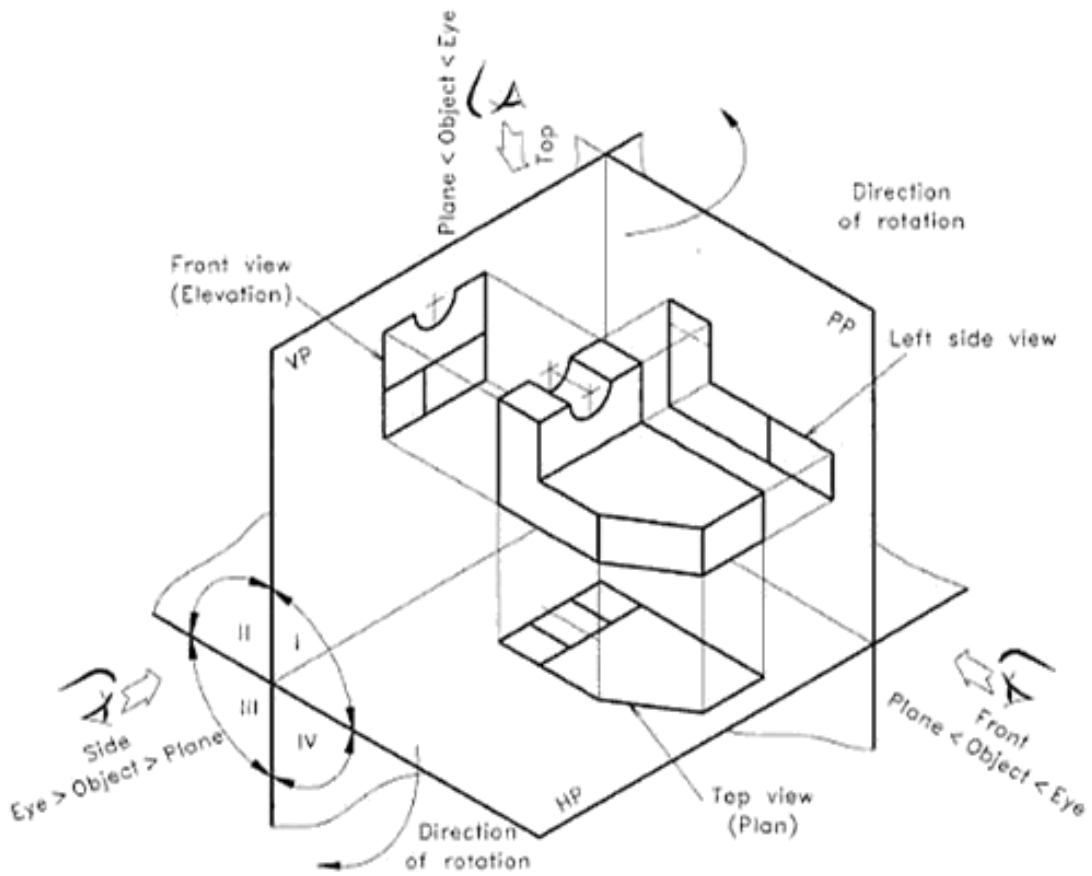
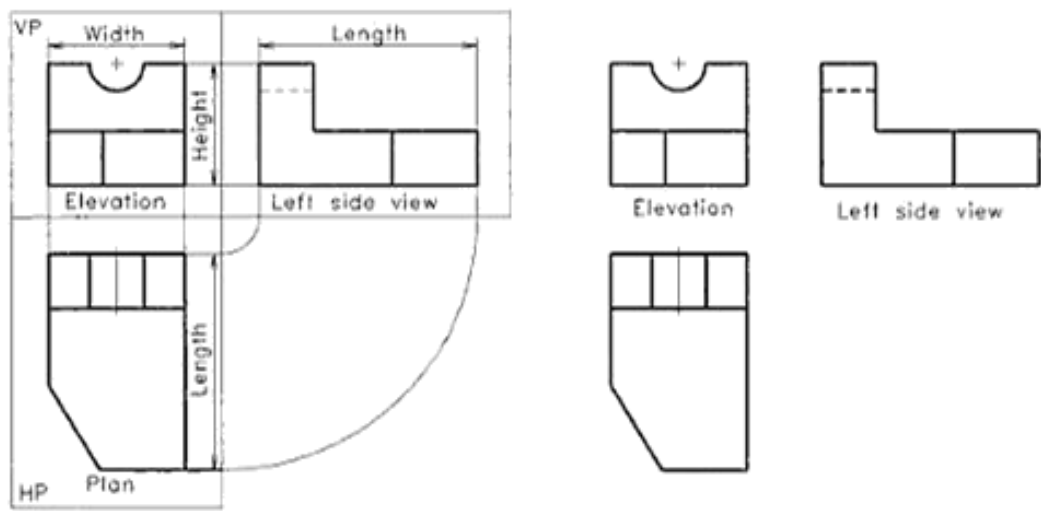

Figure 19.2 First angle projection following anticlockwise system.



(a) Views on the planes (b) Final form of views

Figure 19.3 Layout of the principal views (first angle projection).

Urheberrechtlich geschütztes Material

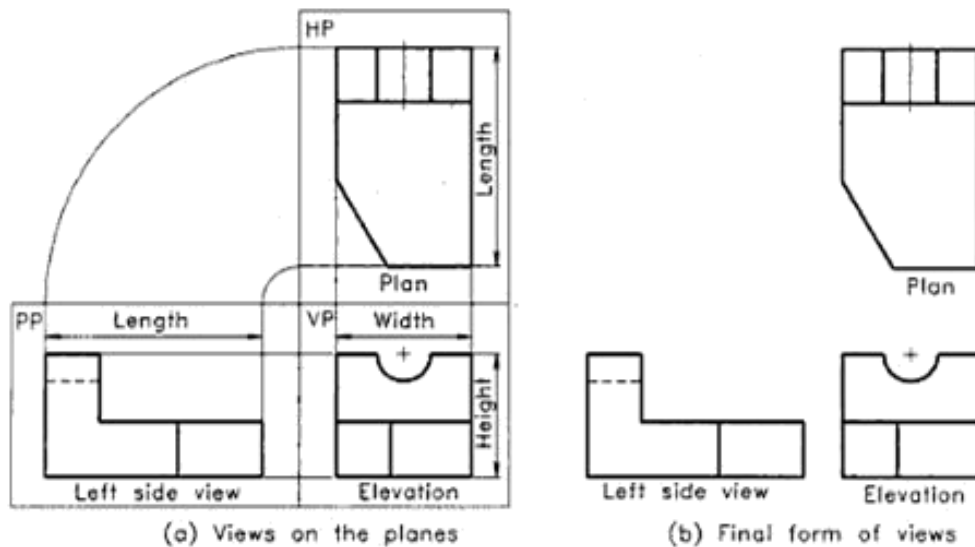

Figure 19.4 Layout of the principal views (third angle projection).

19.4 TRANSPARENT BOX AND THE SIX ORTHOGRAPHIC VIEWS

To describe the shape and size of a complicated object completely on a sheet of paper, sometimes, more than three views are required. In such cases, transparent box method can be used to get six different views of the object. Here, the object is assumed to be placed inside a transparent box, keeping its important face parallel to the front side of the box (see Figure 19.5). The six sides of the box are assumed to be six planes of projection. The observer views the enclosed object from outside. Six views are obtained on the six planes by drawing projectors from various points on the object to these planes. These views are called *front*, *top*, *right side*, *left side*, *bottom* and *rear views*. To transfer these six views, the box is opened to one plane, the plane of the drawing sheet. The six views can be developed by applying the principle of first and third angle projection methods.

In first angle projection method, the object is placed between the eye and the plane of projection. Hence, we follow the *EYE > OBJECT > PLANE* principle.

Consider a transparent box ABCDEFGH containing an object inside it, as shown in Figure 19.5. The following are the views obtained on the six sides of the transparent box.

1. *Front view*: The view of the object formed on the rear side ABCD of the box, when looked in the direction of the arrow marked by FRONT, is called *front view*.
2. *Top view*: The view of the object formed on the bottom

side DCGH of the box, when looked in the direction of the arrow marked by TOP, is called *top view*.

3. *Left side view*: The view of the object formed on the right side BFGC of the box when looked in the direction of the arrow marked by LEFT SIDE, is called *left side view*.

4. *Right side view*: The view of the object formed on the left side AEHD of the box, when looked in the direction of the arrow marked by RIGHT SIDE, is called *right side view*.

5. *Bottom view*: The view of the object formed on the top side ABFE of the box, when looked in the direction of the arrow marked by BOTTOM, is called *bottom view*.

6. *Rear view*: The view of the object formed on the front side EFGH of the box, when looked in the direction of the arrow marked by REAR, is called *rear view*.

Assume that the transparent box is formed by hinging the sides of the box onto the edges of these sides. It may be noted that all the sides of the transparent box except the front side EFGH, are hinged to the four edges AB, BC, CD and DA of the rear side ABCD. The front side EFGH is hinged to the edge FC. There are two hinges on each side. Now to open the box, rotate the sides of the box outwards about the respective hinges as shown in Figure 19.6. All the sides of the box are opened out in such a way that the front view occupies the central position. Continue the process of the rotation until all sides of the box lie in a single plane, the plane of the drawing sheet.

The layout of the six views in first angle projection method is shown in Figure 19.7. The rear view may also be placed to the left-hand side of the right side view.

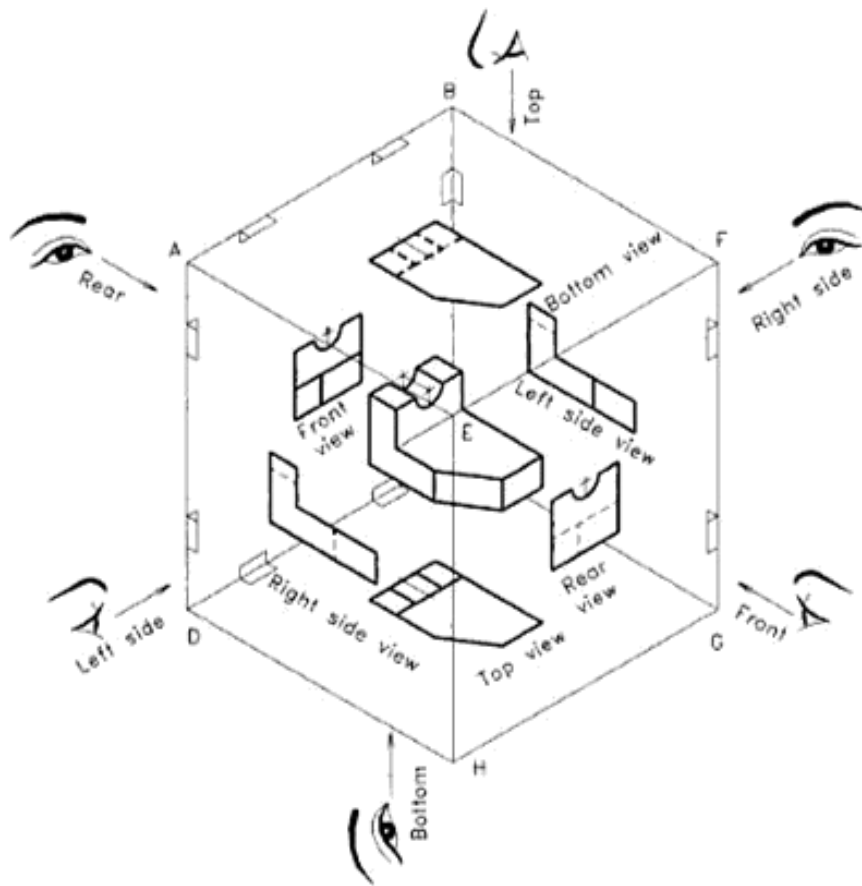

Figure 19.5 Transparent box containing an object (first angle projection).

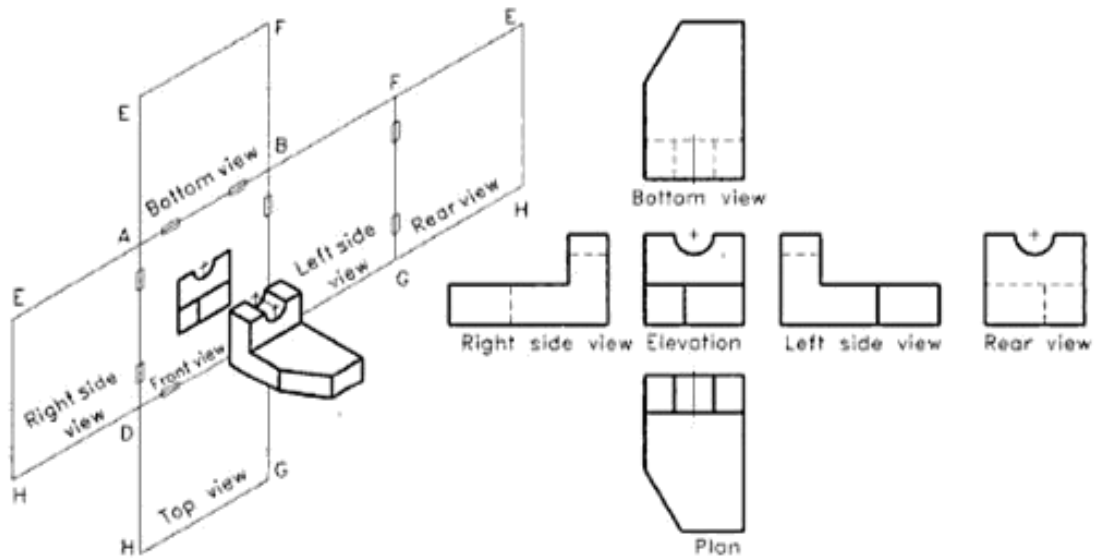

Figure 19.6 Opening of the transparent box (first angle projection).

Figure 19.7 Layout of the six views (first angle projection).

Urheberrechtlich geschütztes Material

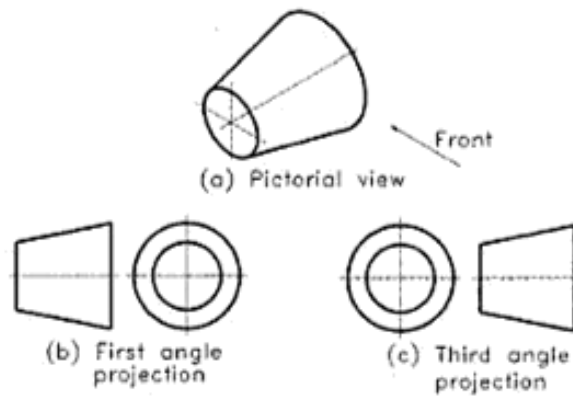

Figure 19.8 Symbol for first angle projection.

19.5 INDICATION OF FIRST ANGLE PROJECTION

The method of projection used, must be indicated inside the space provided in the title block of the drawing sheet. A distinguishing symbol is recommended by the Bureau of Indian Standards for this purpose. The front and left side views of a frustum of a cone lying with its axis horizontal, is used for this. The symbol for first angle projection is shown in Figure 19.8.

19.6 SELECTION OF MINIMUM NUMBER OF VIEWS

For describing the shape of an object completely by its orthographic views, it is necessary to select the number of views required, and combine.

The number of views required for describing an object clearly and completely depends upon the extent of complexity involved in it. Based upon the number of views required, the drawings can be classified into the following categories:

1. One-view drawing
2. Two-view drawing
3. Three-view drawing

It may be noted that only minimum number of views, that will describe the object clearly and completely, should be drawn.

One-view Drawing

An object having cylindrical, square or hexagonal features can be completely described by a single orthographic view. Such a drawing is called *one-view drawing*. Here, the features are expressed by a note or an abbreviation.

In Figure 19.9, the cylindrical part is indicated by the notation ϕ and the square part is indicated by the notation \square . The square part is identified by drawing thin crossed diagonal lines on the feature. Plate of any size can be described by a single orthographic view. The thickness of the plate may be expressed by a note.

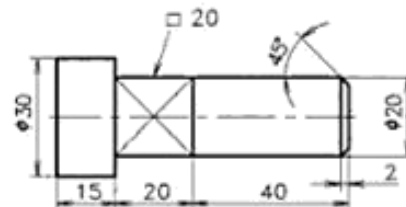

Figure 19.9 A pin (one view drawing).

Two-view Drawing

Objects which are symmetrical about two axes can be represented clearly and completely by two views. Such a drawing is called *two-view drawing*.

The largest face, showing most of the details and having minimum number of hidden lines, is selected as the front view. The second view may be the top or the side view.

It may be noted that any two views will not be sufficient to describe an object completely. Proper combination of the views should be selected. Isometric views of three prisms and the plan of these prisms are shown in Figure 19.10(a). The front and top views of these prisms shown in Figure 19.10(b) are not sufficient to describe them completely. But, the front and side views of these prisms describe the objects clearly and completely. Side views of the prisms are shown in Figure 19.10(c).

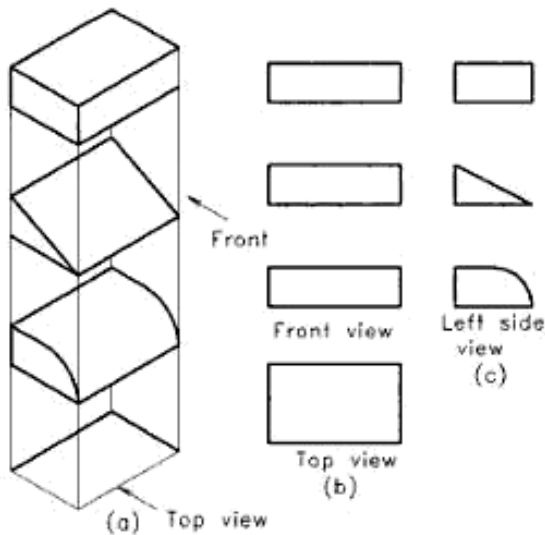

Figure 19.10 Two-view drawing of prisms.

Three-view Drawing

Most of the objects can be represented clearly and completely by three views. Such a drawing is called *three-view drawing*. The largest face showing most of the details is selected as the front view. Here, the object is placed in its functional position as far as possible and with the principal faces parallel to the planes of projection. A three view drawing of a cast iron block is shown in Figure 19.11.

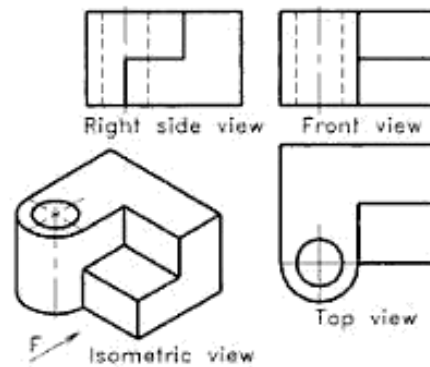

Figure 19.11 Three view drawing of a cast iron block.

19.7 USE OF LINE TYPES AND DIMENSIONING OF VIEWS

Orthographic views are drawn with proper line types as allowed by BIS. Figure 19.12 shows three orthographic views of an object drawn in first angle projection with proper line types and dimensioning. The pictorial view is also given for reference. The important points to be considered are given below.

Line Types for Orthographic View

1. The visible edges and all the outermost edges and surfaces are represented by continuous thick lines, i.e. Type A lines.

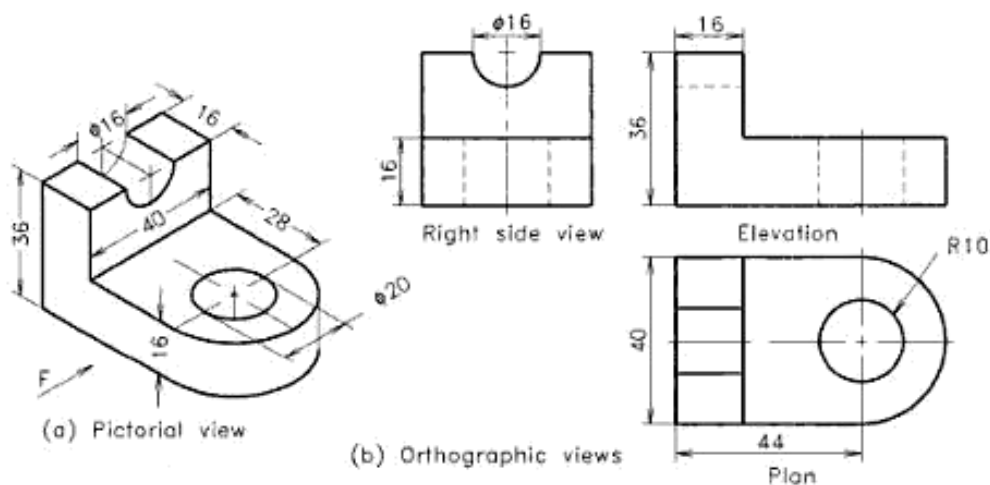

Figure 19.12 A machine part.

2. The hidden details are shown only if they are required. They are represented by short dashes using Type E or F lines. The method of drawing hidden lines and the rules for superimposing them are explained in Chapter 1.
3. Thin chain line (Type G) is used to represent centre lines and lines of symmetry.
4. Orthographic projections of machine parts generally have holes, circles, lines of symmetry, etc. Hence, the fixing of the view location and the further construction of shapes are progressed only after drawing all the important centre lines of the related views.
5. As a rule, a circular hole or projection should be drawn with the centre lines in horizontal and vertical directions. On a pitch circle, the hole centre is represented by the pitch circle drawn with chain line, and an intersecting radial chain line is drawn from the centre of the pitch circle.
6. Thin continuous line (Type B) is used for sketching views, section lines, construction lines and dimension lines.
7. Projection lines and reference lines are assumed to be invisible in the orthographic views of objects, even though they are compulsory for orthographic views of solids. It has to be noted that projection lines are not drawn, but the views and their details should lie in the exact alignment obeying the rules of projection.

Dimensioning of Orthographic Views

1. Dimensioning of orthographic views of objects is done by following Method-1, as described in Chapter 4. Method-2 is also permitted by BIS. Since Method-1 has certain advantages, it is generally followed for machine drawing.
2. The dimension lines are drawn using thin continuous (Type B) lines and the text is printed using thick single stroke letters as explained in Chapter 2.
3. The complete dimensional values have to be shown on the related orthographic views. They may be distributed in all the related views almost evenly.
4. Writing dimensional values on hidden details and over the view should be avoided.
5. There is no need of repeating a dimension, directly or indirectly. For example, the closing dimension has to be avoided if the total length is given.
6. For more details about dimensioning, refer to Chapter 4.

19.8 SUGGESTED DRAFTING PROCEDURE

To develop speed and accuracy in drawing, it is better to follow a certain order of drafting. All the instruments required for drawing should be placed at their proper locations in order to save time. The steps to be followed in making orthographic views are suggested below:

1. Decide the directions of the principal view (front view) and the combination of views such that it will best describe the object. Prepare freehand sketches of the required views and mark the overall dimensions on these views.
2. Considering the number of views to be drawn, with their overall dimensions and the size of the drawing sheet being given, select a suitable scale. But in industrial practice, the size of the drawing sheet is to be selected according to the number of views, overall dimensions and the scale of the drawing. The scale should be selected without spoiling the clarity of the drawing.
3. Draw the border line and outline of the title block. Leave sufficient space in between the views and the border line of the sheet. Care must be taken to provide necessary space for printing dimensions, notes, etc. [see Figure 19.13(b)]. As far as possible, provide equal space between the views for a better appearance.
4. Mark centre lines at appropriate places [see Figure 19.13(c)].
5. As far as possible, draw the details simultaneously in all the views. The following order of priority may be preferred as:
 1. Circles and arcs
 2. Straight lines which form the major shape of the object
 3. Straight lines, curves for the minor details like fillets, rounds, etc.
6. Draw all the details, except the hidden lines in all the views.
7. Erase all the unnecessary lines, construction lines, etc. Finish the drawing by thickening the appropriate lines.
8. Draw the hidden lines [see Figure 19.13(f)].
9. Enter all the dimensional values, distributing them appropriately in all the views.
10. Draw section lines, if any.
11. Name the views if necessary. Also enter other data necessary for the completion of the drawing. Check the drawing carefully and see whether there is any missing dimension, details, etc.
12. Print the title block details.

Urheberrechtlich geschütztes Material

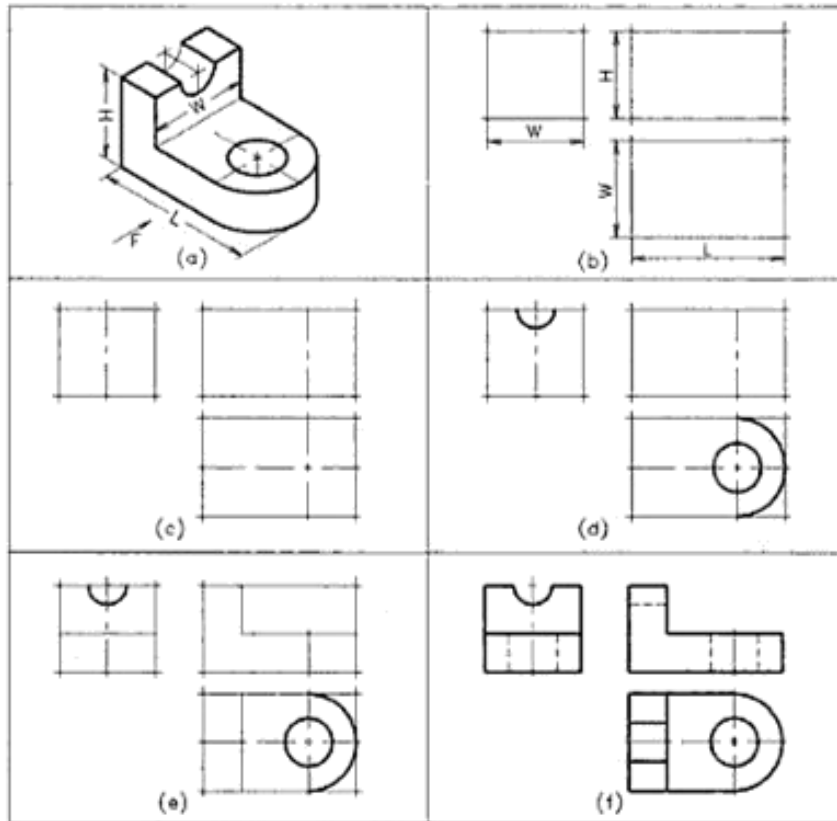

Figure 19.13 Drawing procedure for orthographic views.

Notes

1. Unless and otherwise specified, follow first angle projection method.
2. Symbol of the projection should be shown in the title block of the drawing sheet.
3. If third angle projection method is used along with first angle projection as a special requirement, it should be shown below the drawing by symbol or in writing.
4. Students are advised to name the orthographic views below them, until they develop the capacity to identify the views.
5. Projection lines and construction lines are not shown in orthographic views of objects.
6. Every circle should have two centre lines intersecting at the centre.
7. Axis of symmetry as well as axis of cylindrical holes, etc. should be drawn with the centre lines.
8. Choose a larger scale always for better clarity of views.
9. The hidden lines in a drawing should be minimised by orienting the object properly. Unimportant

hidden details may be avoided, especially when the drawing is a complicated one.

10. While orienting an object for orthographic projection, the most important vertical face should be selected for the front view.
11. Front view is assumed to be the primary view for orthographic projection and all the remaining views are oriented in relation to the front view.
12. All the views should be drawn in the correct location with respect to front view as if there are projection lines. Shifted position of a view is assumed to be a spelling or grammar mistake, which will lead to wrong meanings in the graphic language.

19.9 FIRST ANGLE PROJECT OF OBJECTS HAVING PLANE SURFACES

Objects having plane surfaces alone may have the surface parallel to, inclined to or oblique to the reference planes. Figure 19.14 shows simple examples to these type of surfaces.

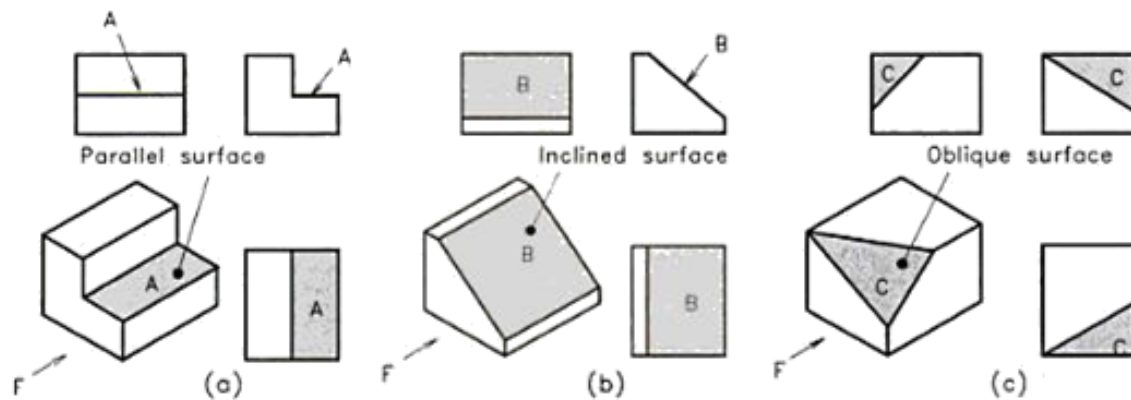

Figure 19.14 Objects having plane surfaces.

Parallel Surface

If a surface of an object is parallel to one of the reference planes of projection, the projection of the surface on that plane to which it is parallel will have its true size and shape. The projection of a surface which is normal to the plane of projection, is represented by a straight line.

Inclined Surface

If a surface of an object is perpendicular to one of the principal planes and inclined to the other two principal planes, the projections of the surface to which it is perpendicular will be a straight line, inclined to the other two reference lines. The projections of the surface on the reference planes to which it is inclined will appear foreshortened.

Oblique Surface

If a surface of an object is inclined to the three reference planes, the surface can be called as an *oblique surface*. If a surface is an oblique one, its projection will show areas on the three reference planes can be represented only by areas which will not give its true size and shape.

The following examples illustrate how orthographic

views are drawn from pictorial views of objects having the above three types of plane surfaces.

Example 19.1

An isometric view of a parallel key is shown in Figure 19.15(a). Draw its front, top and left side views. The direction of the arrow, *F* shows the front side of the key.

Refer Figure 19.15(b). Follow the procedure explained in Section 1.8 to get the views.

Example 19.2

Draw the front, top and right side views of the angle-bracket shown in Figure 19.16(a).

Refer Figure 19.16(b). Follow the procedure explained in Section 19.8.

Example 19.3

Figure 19.17(a) shows an isometric view of a rectangular block having an oblique surface. Draw the front view looking in the direction of *F*. Add the top and the right side views.

Refer Figure 19.17(b). Follow the procedure explained in Section 19.8.

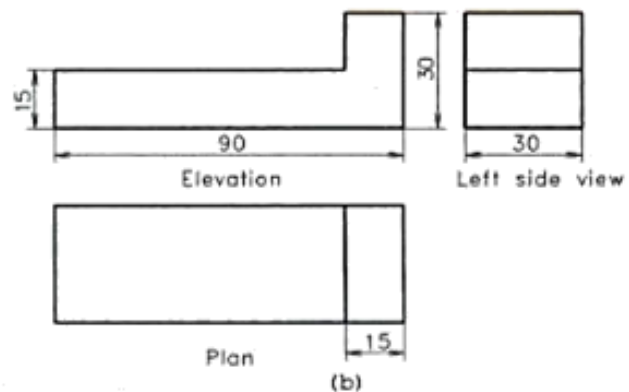
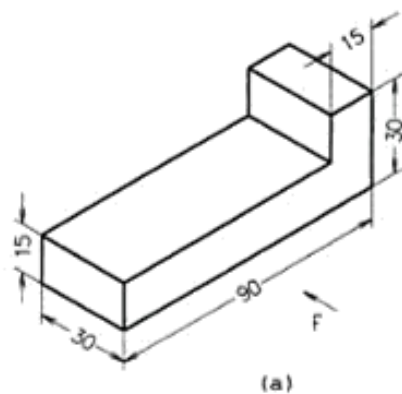

Figure 19.15 Parallel key.

Urheberrechtlich geschütztes Material

weak. The radius of a fillet depends upon the thickness of the metal and other design requirements.

A rounded external corner on a casting is called *round*. External corners or angles are rounded for the appearance and comfort of persons who handle the casting.

Filletts and rounds actually prevent intersecting surfaces as they eliminate abrupt change in direction. This leads to certain problems in orthographic projections and the view becomes confusing (see Figure 19.19). To avoid this, lines are projected from approximate intersections.

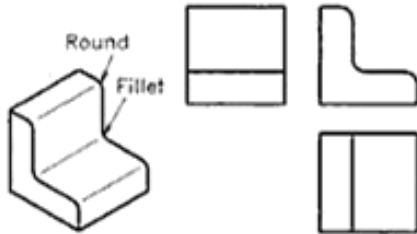

Figure 19.19 Fillets and rounds.

The radius of a fillet or round may sometimes be given on the view itself or as a general instruction. If the radius is not specified but the shape is shown in the given view, the radius may be assumed as 3 to 6 mm depending on the size of the object.

Example 19.4

Draw the three principal views of a cylindrical block shown in Figure 19.20(a).

Refer Figure 19.20(b).

Follow the procedure explained in Section 19.8.

Example 19.5

Isometric view of a shaft support is shown in Figure 19.21(a).

Draw the front view, looking in the direction of the arrow *F*. Also draw top and the side views. Use a suitable scale.

Refer Figure 19.21(b).

Follow the procedure explained in Section 19.8.

Example 19.6

Isometric view of an object is shown in Figure 19.22(a). Draw the front view, looking in the direction of the arrow *F*.

Also draw top and the side views. Use a suitable scale.

Refer Figure 19.22(b).

Follow the procedure explained in Section 19.8.

19.11 THIRD ANGLE PROJECTION OF OBJECTS

In the third angle system of projection, the object is assumed to be placed in the third quadrant and the views are obtained in the same side of viewing as explained in the Section 19.3. Except the change of position of views, there is no practical difference between first angle projection and third angle projection. In third angle projection, the top view is obtained on the top side of front view, the right side view is obtained on the right side of front view, and so on. This difference may be noted in the following example.

Example 19.7

Draw the front, top and right side views of an adjustable rod support shown in Figure 19.23(a). Use third angle projection method.

Refer Figure 19.23(b).

Draw the views as shown in figure, following the procedure explained above. Add an extra note "THIRD ANGLE PROJECTION" below the views.

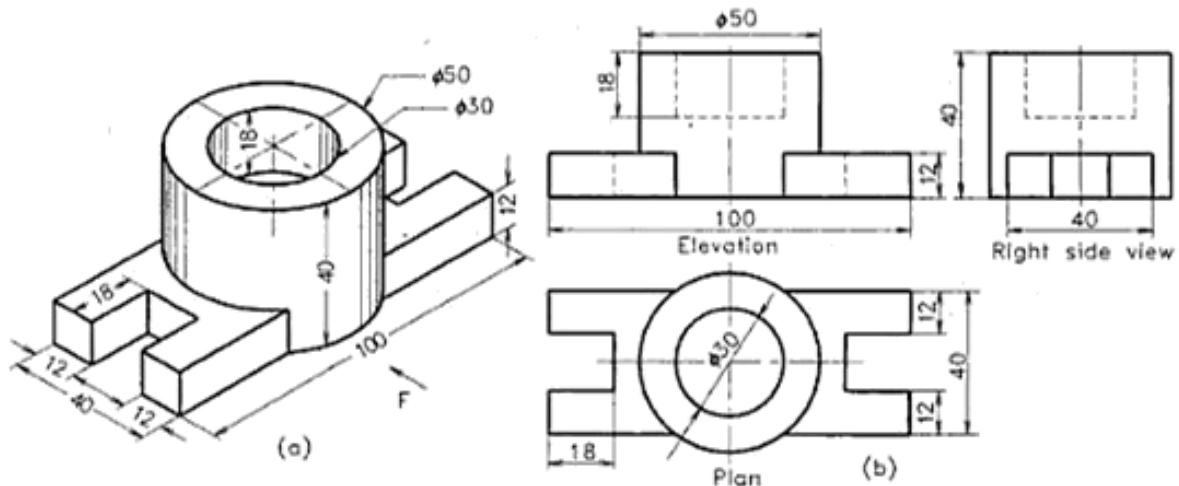

Figure 19.20 Cylindrical block.

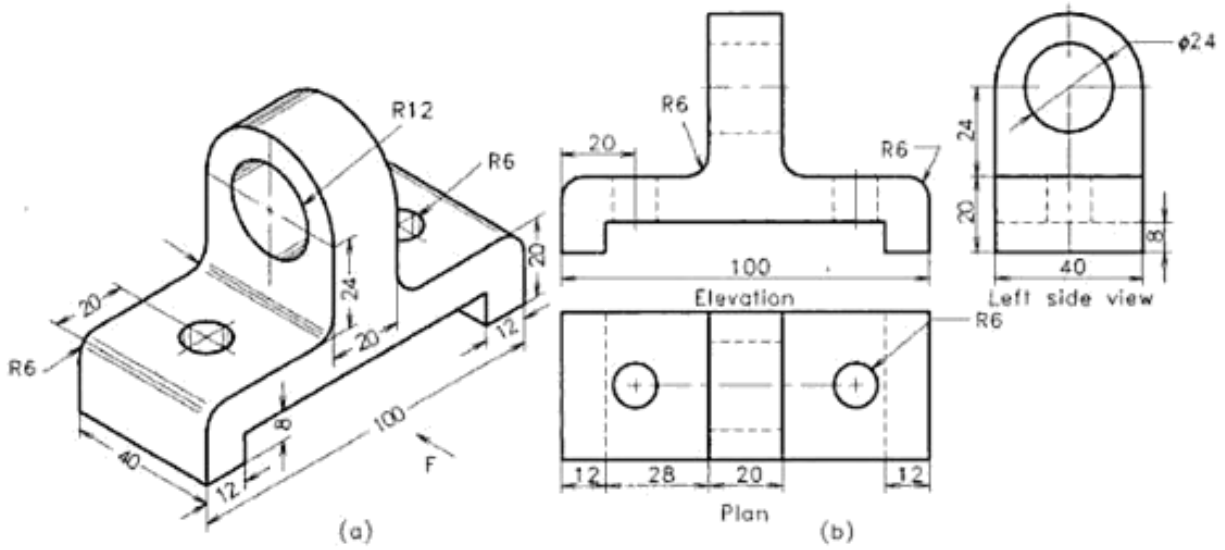

Figure 19.21 Shaft support.

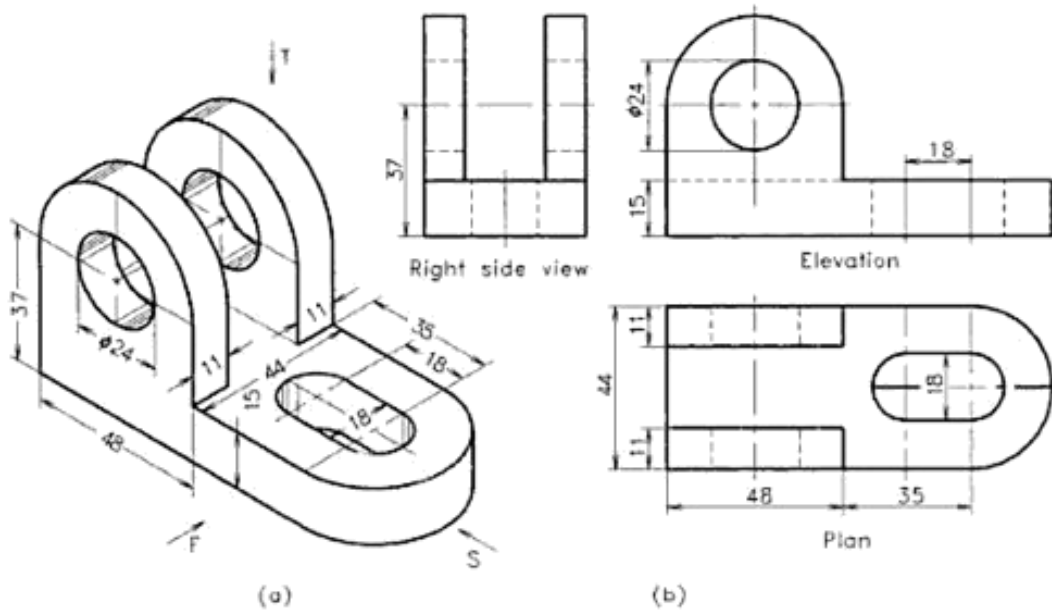

Figure 19.22 Bearing block.

Urheberrechtlich geschütztes Material

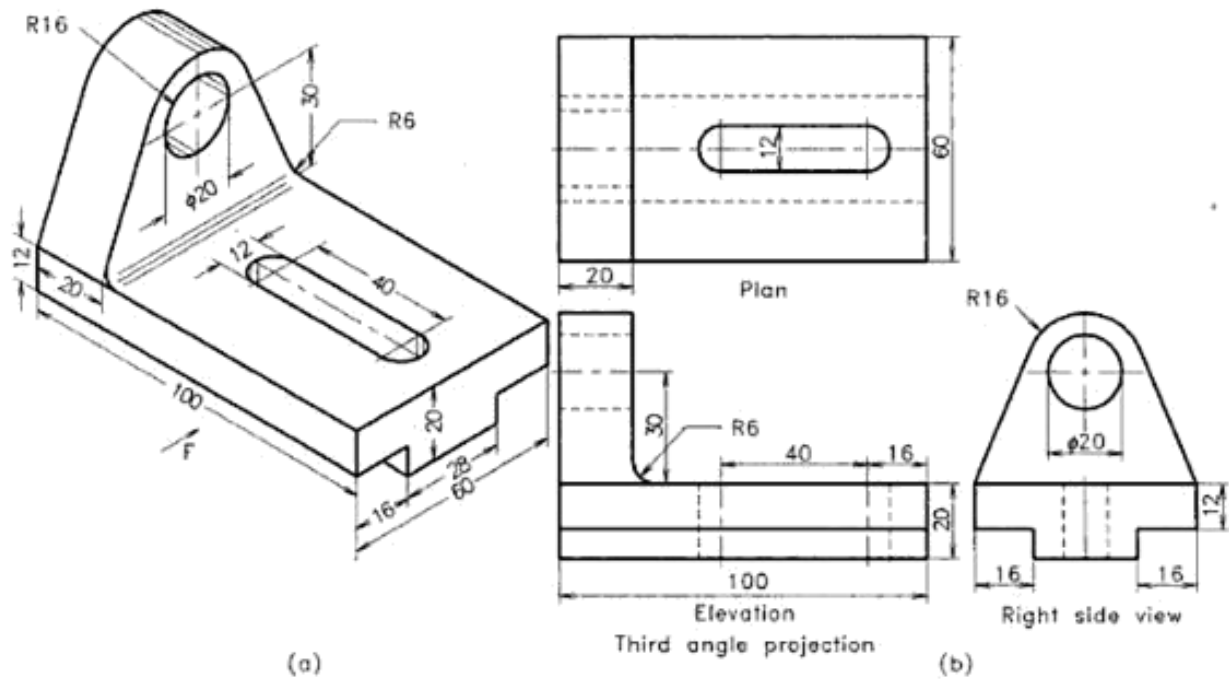

Figure 3.23 Adjustable rod support.

EXERCISES

Draw the orthographic views of the engineering objects as per the instructions given along with the Figures 19.24 to

19.40. View the objects in the direction of arrow marked with F. Name the view and dimension them as per BIS.

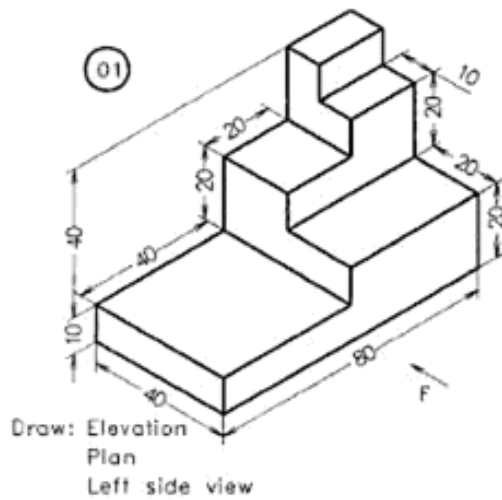

Figure 19.24 A block.

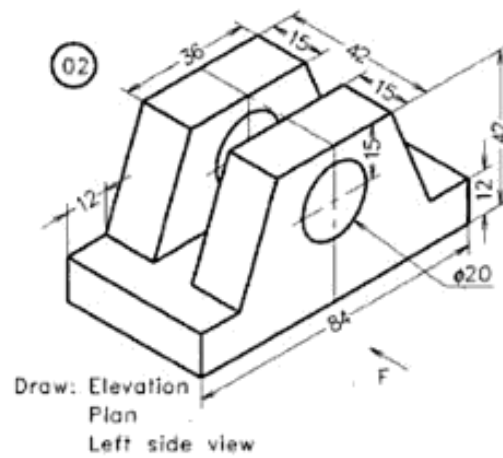
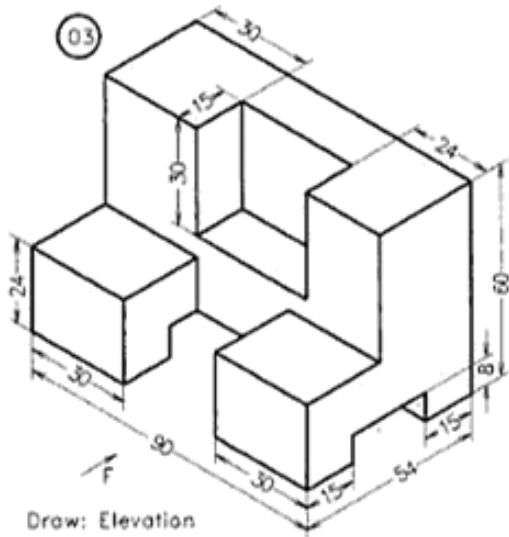

Figure 19.25 A block.

Urheberrechtlich geschütztes Material



Draw: Elevation
Plan
Left side view

Figure 19.26 A block.

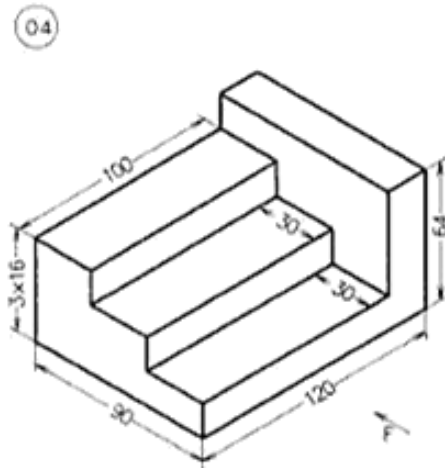

Draw: Elevation
Plan
Left side view

Figure 19.27 A stepped block.

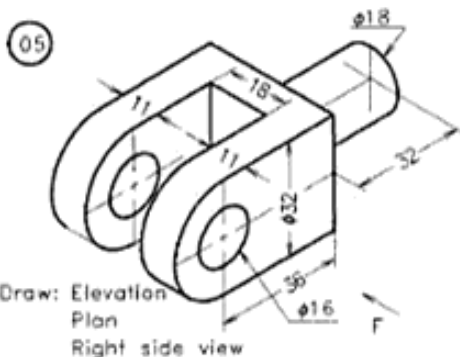

Draw: Elevation
Plan
Right side view

Figure 19.28 Fork end.

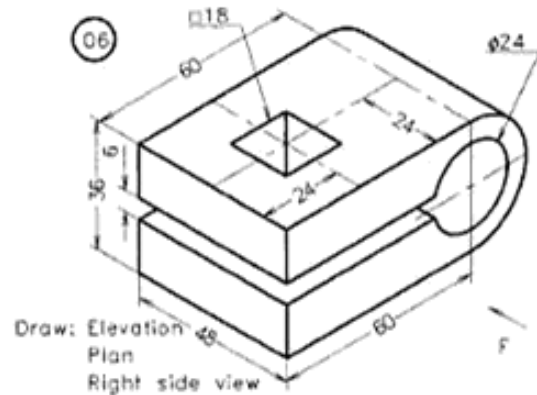

Draw: Elevation
Plan
Right side view

Figure 19.29 Fork end.

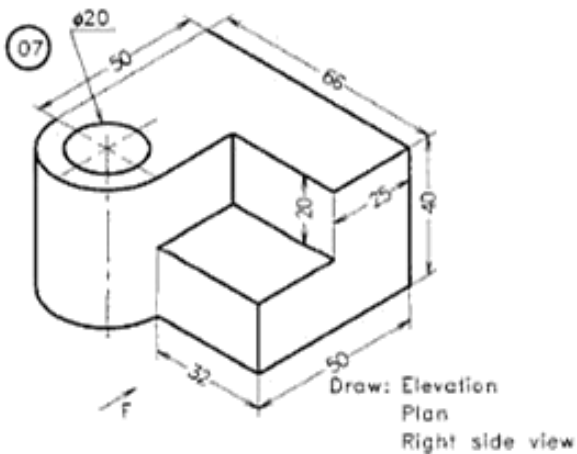

Draw: Elevation
Plan
Right side view

Figure 19.30 A cast iron block.

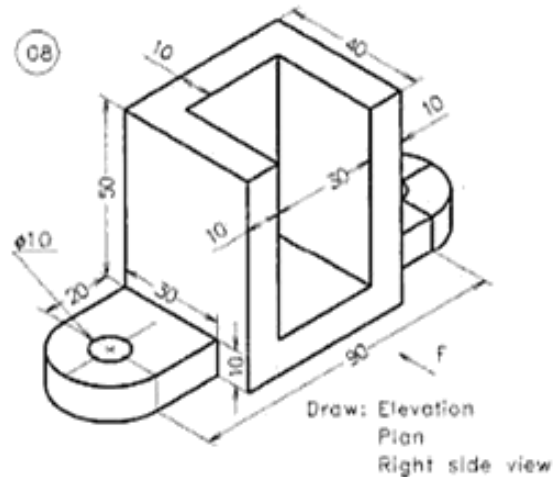

Draw: Elevation
Plan
Right side view

Figure 19.31 Astopper.

Urheberrechtlich geschütztes Material

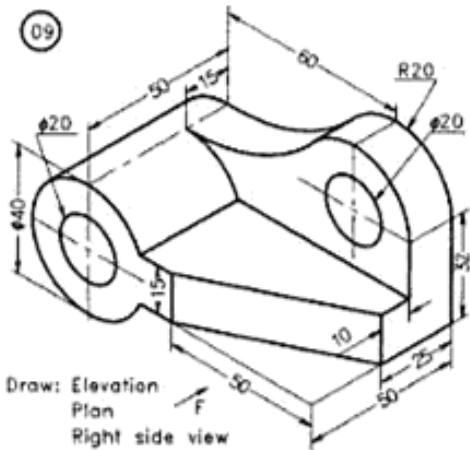

Draw: Elevation
Plan
Right side view

Figure 19.32 A shaft support.

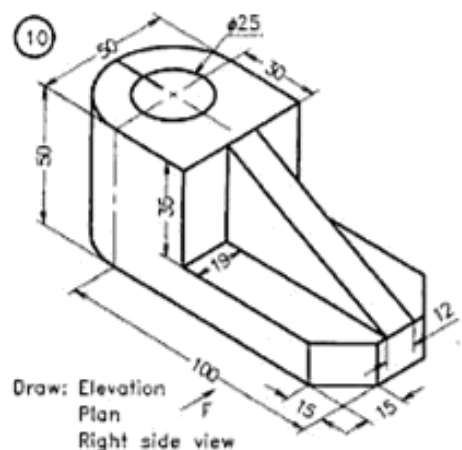

Draw: Elevation
Plan
Right side view

Figure 19.33 A block.

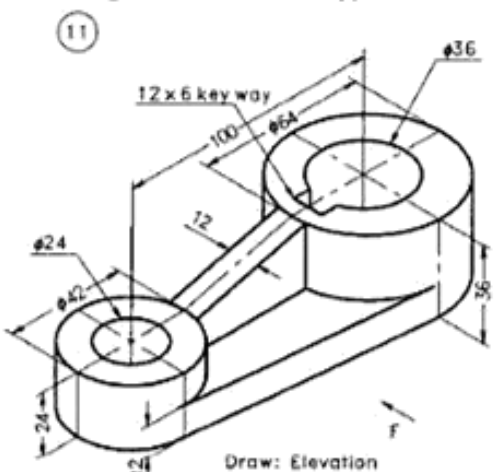

Draw: Elevation
Plan
Right side view

Figure 19.34 A lever.

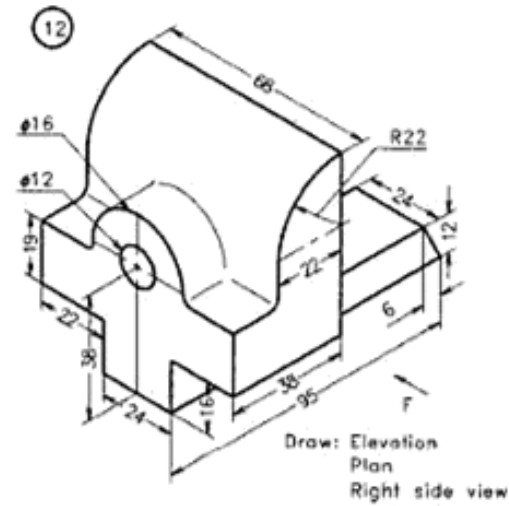

Draw: Elevation
Plan
Right side view

Figure 19.35 Jaw of a vice.

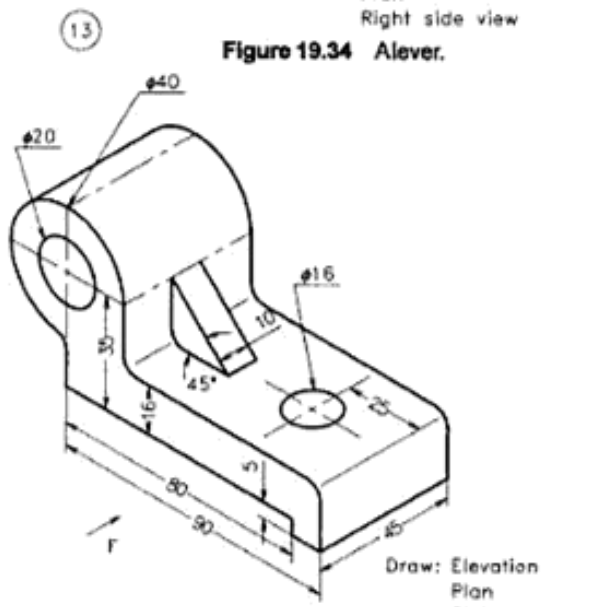

Draw: Elevation
Plan
Right side view

Figure 19.36 A bearing.

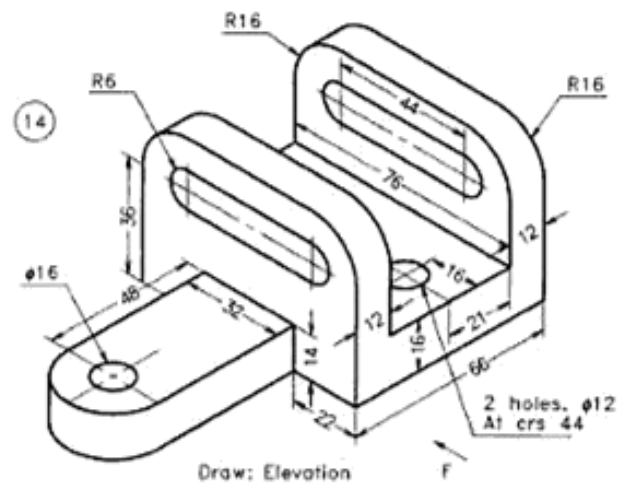

Draw: Elevation
Plan
Right side view

Figure 19.37 A bracket.

Urheberrechtlich geschütztes Material